

GRANBERING INTEGRAL ULTRA

CLEANING INSTRUCTION

Modello - Modèle - Model Modell - Modelo - Modelo	GRANBERING INTEGRAL ULTRA	COSTAN <small>eptarefrigeration</small>
Fabbricante - Constructeur - Manufacturer Hersteller - Fabricante - Fabricante	Epta Spa - Via Mecenate, 86 - 20138 Milano (MI) ITALIA Tel. 02/55403211 Telefax 02/55401023	2/11

Cleaning instruction

IT
FR
EN
DE
ES
PT

INDICE

1. Introduzione	2
1.1 Introduzione	2
1.2 Informazioni generali di sicurezza	2
1.3 Motivi per la pulizia	2
2. Materiali e detergenti	3
3. Pulizia dell'apparecchiatura	4
3.1 Pulizia dell'esterno dell'apparecchiatura	4
3.2 Pulizia dell'interno dell'apparecchiatura	4
3.3 Rimuovere il cestone	5
3.4 Pulizia del piano di fondo	8
3.5 Pulizia del condensatore	9
3.6 Pulizia della bacinella di raccolta dell'acqua	10
3.7 Riaccensione del banco	10

SIMBOLOGIA UTILIZZATA



Simbolo divieto: vieta di effettuare determinate operazioni.



Simbolo attenzione: norme antinfortunistiche per l'operatore.



Simbolo avvertenze: esiste la possibilità di arrecare danno al banco e/o ai suoi componenti.



Simbolo nota: fornisce informazioni utili.

Dispositivi di protezione individuali

	Scarpe antinfortunistiche
	Guanti protettivi
	Occhiali di sicurezza
	Elmetto di sicurezza
	Gilet catarifrangente

Modello - Modèle - Model Modell - Modelo - Modelo	GRANBERING INTEGRAL ULTRA	COSTAN <small>eptarefrigeration</small>
Fabbricante - Constructeur - Manufacturer Hersteller - Fabricante - Fabricante	Epta Spa - Via Mecenate, 86 - 20138 Milano (MI) ITALIA Tel. 02/55403211 Telefax 02/55401023	3/11

1. INTRODUZIONE

1.1 Introduzione

Il documento "Cleaning Instructions" indica come pulire l'espositore di prodotti refrigerati per surgelati.

Le istruzioni d'uso sono disponibili anche su:
www.eptarefrigeration.com.

1.2 Informazioni generali di sicurezza



Non interrompere la catena del freddo dei prodotti esposti.



Prima di qualsiasi operazione di manutenzione e pulizia, disconnettere il banco dalla rete elettrica ed assicurarsi che il personale non autorizzato possa riconnettere l'alimentazione elettrica.



Assicurarsi che la zona di lavoro sia sufficientemente illuminata durante le operazioni di pulizia e manutenzione. Utilizzare ulteriori fonti di illuminazione se necessario.



Le porte e le pareti in vetro sono dotate all'interno di una pellicola antiappannamento. Non utilizzare detergenti contenenti sostanze abrasive, fortemente acide o caustiche.



Fare attenzione a non toccare parti in rotazione del banco (ventolatori) con le dita, asciugamani o altri strumenti.



Non rimuovere le protezioni e le coperture di protezione.

1.3 Motivi per la pulizia

Per presentare le merci in modo attraente e igienico, è importante pulire regolarmente il banco. Una pulizia regolare impedisce inoltre che muffe e batteri nocivi si depositino nel banco, poiché la polvere umida fornisce un terreno fertile ideale.

La pulizia regolare è essenziale anche per la funzione tecnica. Questo è l'unico modo per garantire uno scambio termico ottimale e che l'aria possa fluire facilmente nel banco.

IT

FR

EN

DE

ES

PT

Modello - Modèle - Model Modell - Modelo - Modelo	GRANBERING INTEGRAL ULTRA	COSTAN  <small>eptarefrigeration</small>
Fabbricante - Constructeur - Manufacturer Hersteller - Fabricante - Fabricante	Epta Spa - Via Mecenate, 86 - 20138 Milano (MI) ITALIA Tel. 02/55403211 Telefax 02/55401023	4/11

Cleaning instruction

IT
FR
EN
DE
ES
PT

2. MATERIALI E DETERGENTI

Abiti da lavoro

- Guanti protettivi
- Indumenti protettivi
- Occhiali di sicurezza

Detergente per superfici diverse dal vetro

- Acqua
- Detergente delicato
- Spugne, stracci e panni morbidi antigraffio

Detergente per superfici in vetro

- Acqua
- Detergente delicato
- Detergente per vetri standard
- Smacchiatori d'olio
- Spugne, stracci e asciugamani di carta antigraffio

Quanto segue non deve essere utilizzato

- Detergenti fortemente corrosivi
- Detergenti acidi o caustici
- Agenti infiammabili
- Acetone
- Agenti detergenti contenenti solventi
- Detergenti abrasivi
- Detergente a getto d'acqua o altro getto d'acqua forte per pulire

Modello - Modèle - Model Modell - Modelo - Modelo	GRANBERING INTEGRAL ULTRA	COSTAN eptarefrigeration
Fabbricante - Constructeur - Manufacturer Hersteller - Fabricante - Fabricante	Epta Spa - Via Mecenate, 86 - 20138 Milano (MI) ITALIA Tel. 02/55403211 Telefax 02/55401023	5/11

3. PULIZIA DELL'APPARECCHIATURA

3.1 Pulizia dell'esterno dell'apparecchiatura

- Lavare l'esterno dell'apparecchiatura solamente con acqua tiepida e sapone neutro o detergente neutro
- Asciugare con cura con spugne non abrasive antigraffio, stracci e panni morbidi

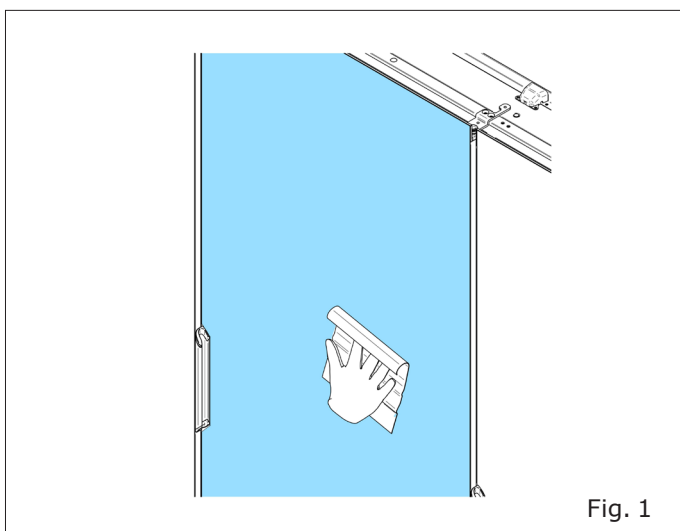

Pulizia delle porte vetrate e delle parti vetrate interne:

- Lavare le parti in vetro con prodotti specifici per vetri e con spugne non abrasive antigraffio, stracci o panni di carta.

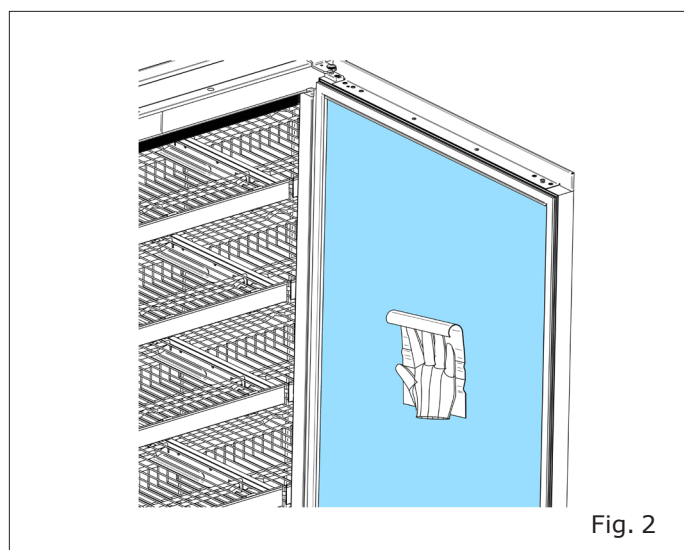

Eventuali residui di grasso devono essere rimossi con specifici smacchiatori.

3.2 Pulizia dell'interno dell'apparecchiatura

- Rimuovere i prodotti refrigerati esposti in congelatori o celle refrigerate per surgelati.
- Evitare le interruzioni nella catena del freddo dei prodotti esposti nell'apparecchiatura
- Disconnettere l'apparecchiatura dalla rete elettrica e assicurare che la riconnessione possa essere effettuata solo da personale autorizzato.

Pulizia dei ripiani:

- Le superfici devono essere lavate con acqua tiepida e sapone neutro o detergente neutro.

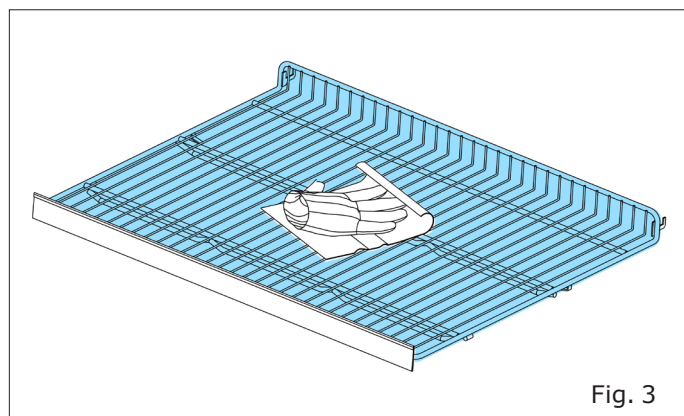

Cleaning instruction

IT
FR
EN
DE
ES
PT

- Per agevolare le operazioni di pulizia è possibile rimuovere i ripiani dalle loro posizioni nella scaffalatura.

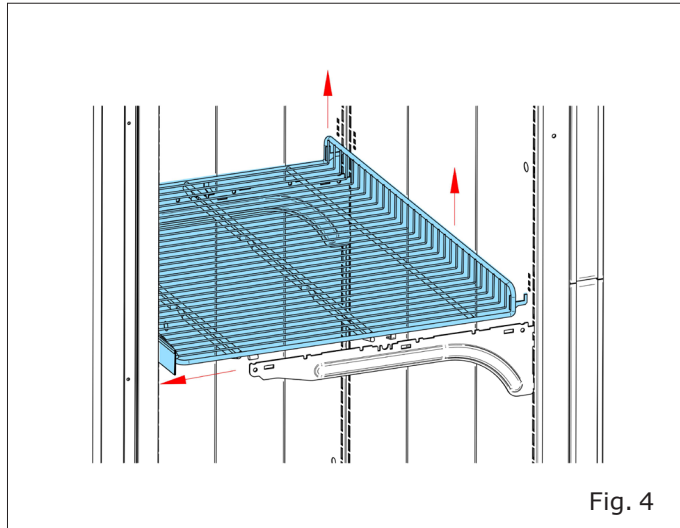

Ruotare il ripiano prima di estrarlo dal banco.

- Assicurarsi che le staffe di supporto dei ripiani siano nella posizione corretta e completamente bloccate nei loro supporti durante la reinstallazione.

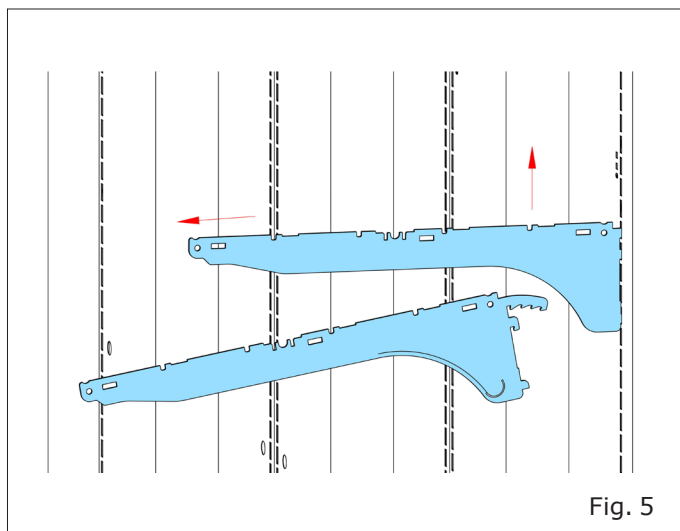

Pulizia della griglia di ripresa dell'aria:

- Pulire la griglia di ripresa dell'aria con un aspirapolvere e/o con un panno umido.

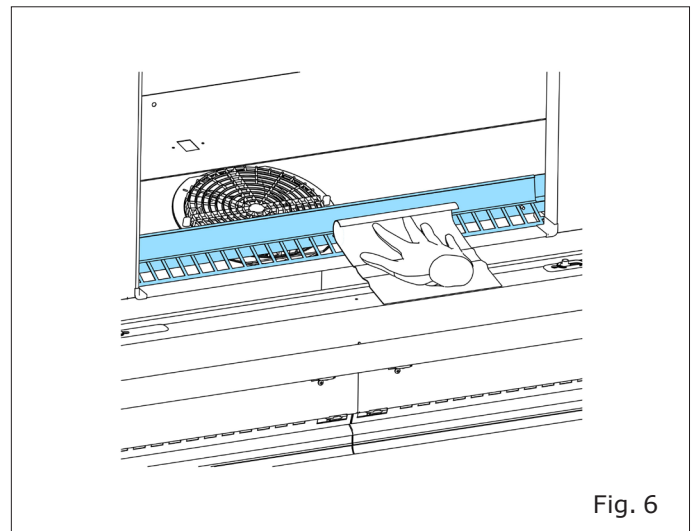

3.3 Rimuovere il cestone

- Il banco può essere fornito con i cestoni estraibili.

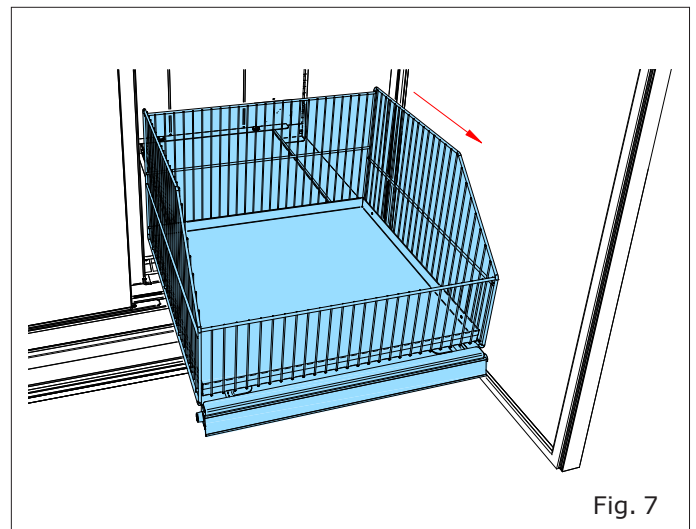

- Può essere rimosso per la pulizia.
- Per fare ciò, estrarre il cestone dal banco e rimuovere i due dadi zigrinati. Il cestone può quindi essere rimosso.

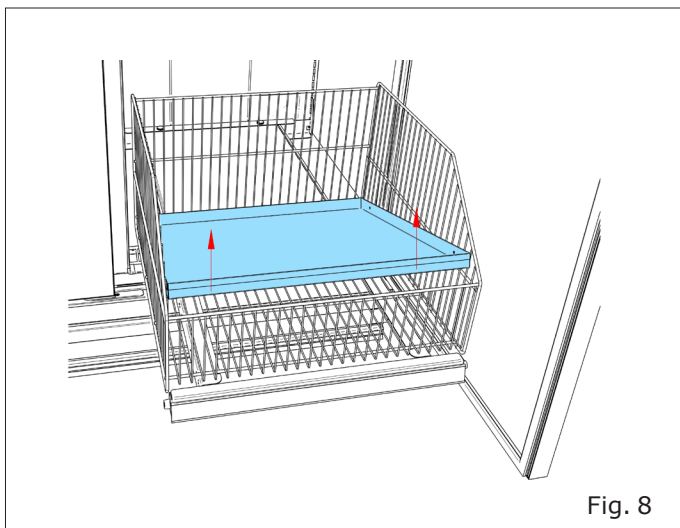

Rimuovere il pannello interno.

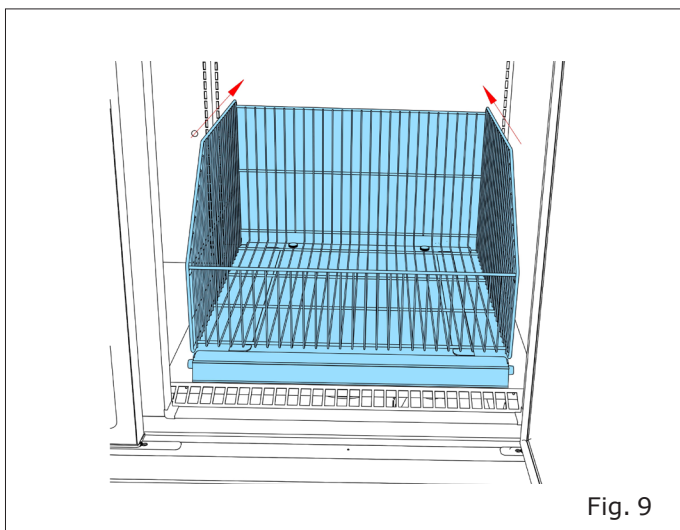

Posiziona il cestone all'interno per rimuovere i dadi zigrinati.

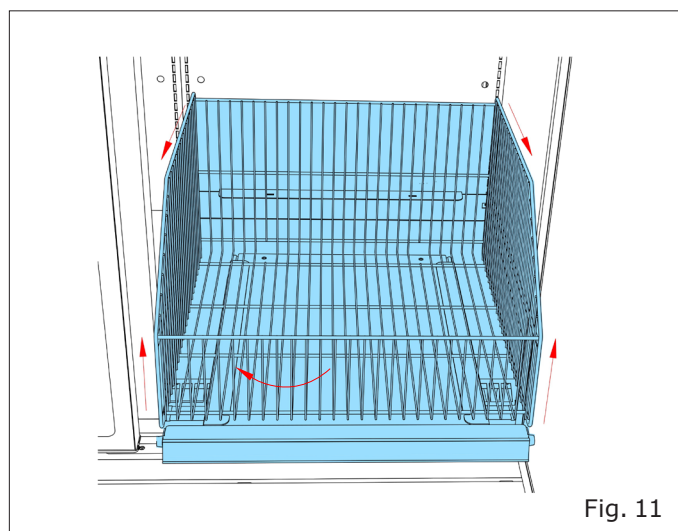
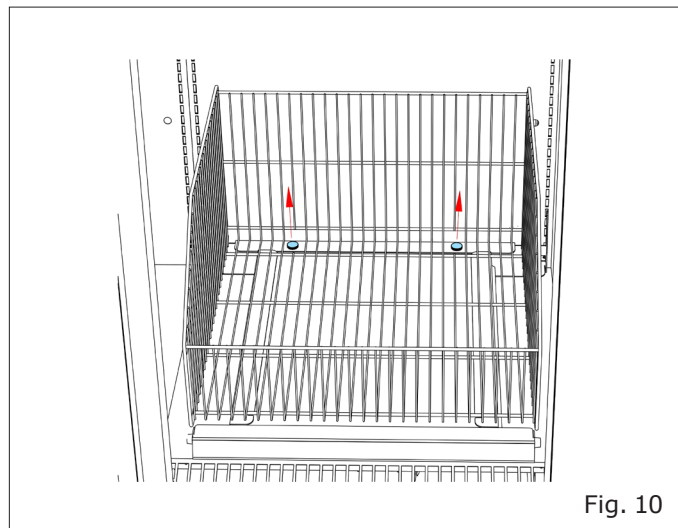

IT

FR

EN

DE

ES

PT

Cleaning instruction

IT
FR
EN
DE
ES
PT

- Per reinstallare il cestone procedere in ordine inverso. Allineare il cestone e fissarlo con i dadi zigrinati.
- Conservare con cura i dadi zigrinati e riposizionarli dopo la pulizia per fissare il cestone.

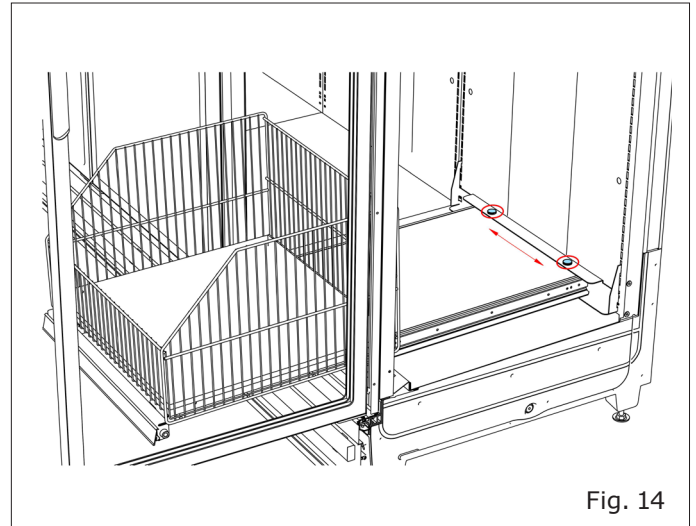
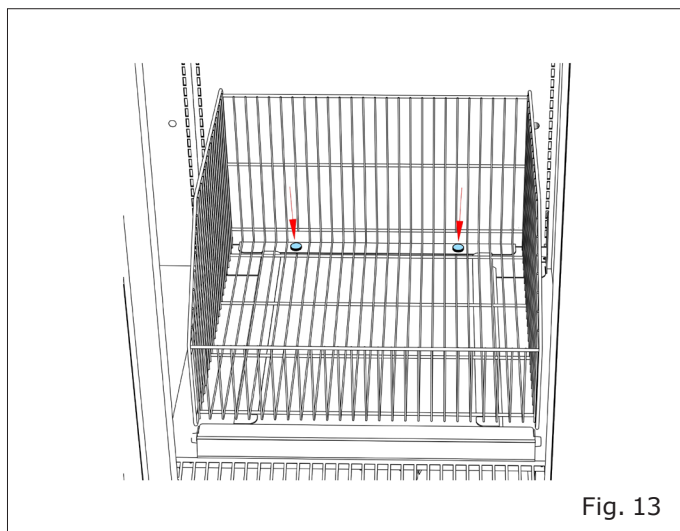
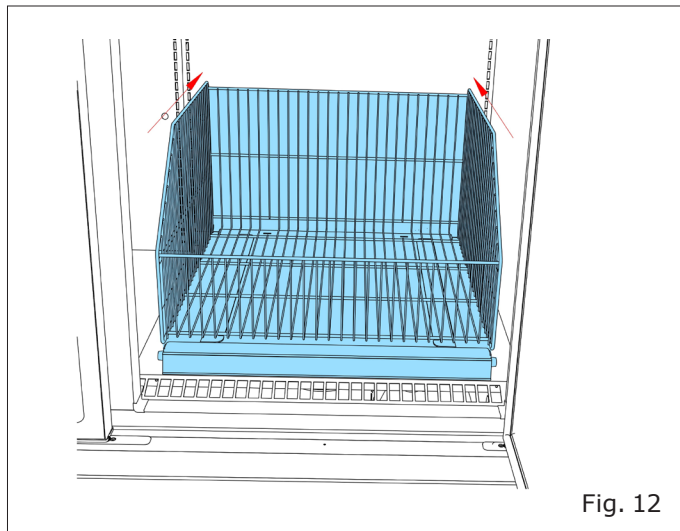

Controllare attentamente che il cestone non tocchi nessuna cornice o guarnizione dell'apparecchiatura o dell'anta.

3.4 Pulizia del piano di fondo



La pulizia del piano di fondo deve essere eseguita solamente da personale addestrato.

- Rimuovere i prodotti refrigerati esposti in congelatori o celle refrigerate per surgelati.
- Evitare le interruzioni nella catena del freddo dei prodotti esposti nell'apparecchiatura
- Disconnettere l'apparecchiatura dalla rete elettrica e assicurare che la riconnessione possa essere effettuata solo da personale autorizzato.
- Rimuovere il cestone come descritto nel capitolo "Rimuovere il cestone".

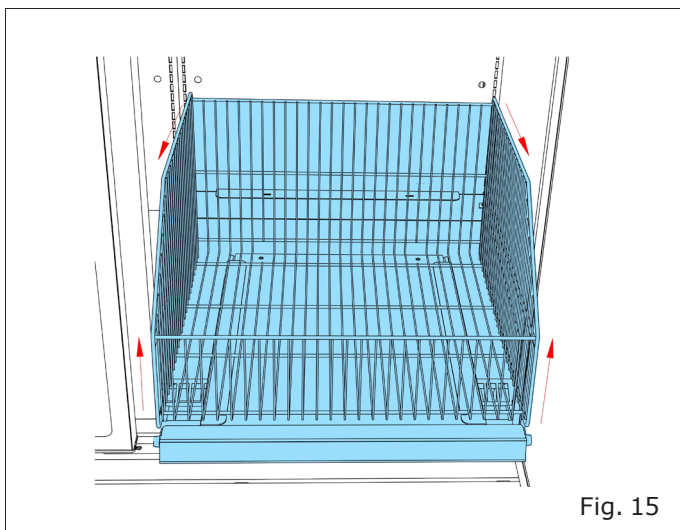

Fig. 15

- Pulire il piano di fondo con uno straccio umido.

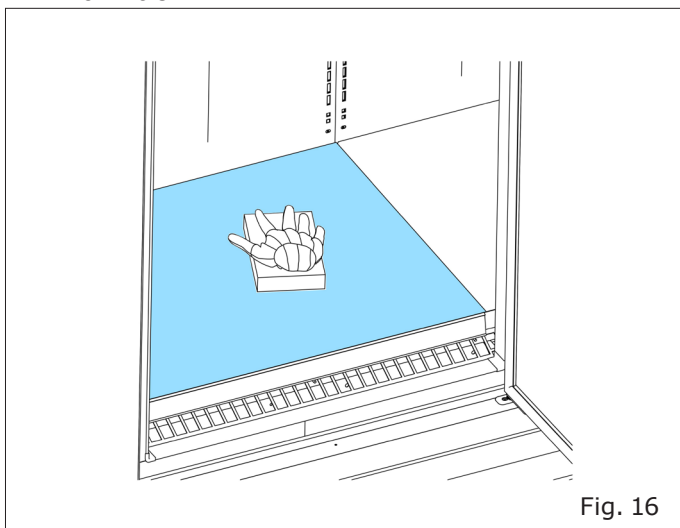

Fig. 16

- Rimuoverlo.

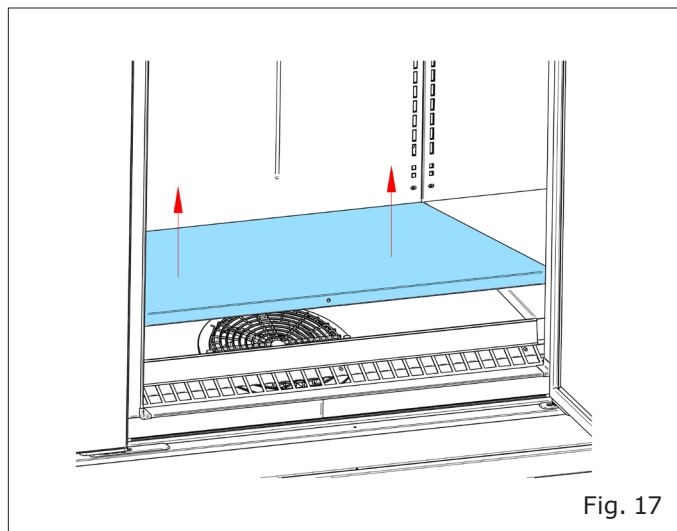

Fig. 17

- Rimuovere la griglia di ripresa dell'aria, la griglia di mandata dell'aria e pulirle utilizzando un panno umido.

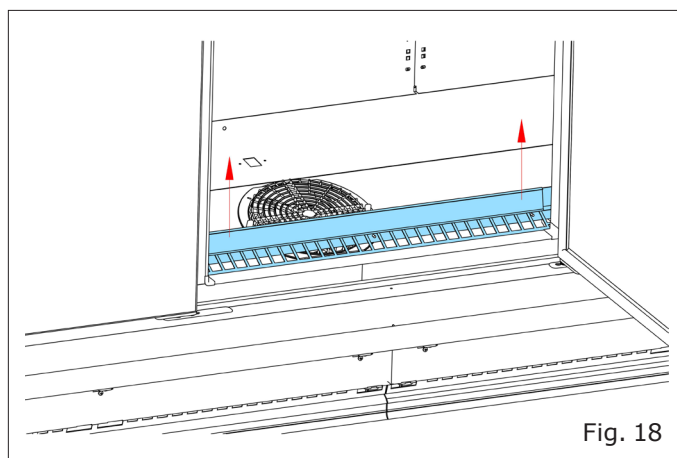

Fig. 18

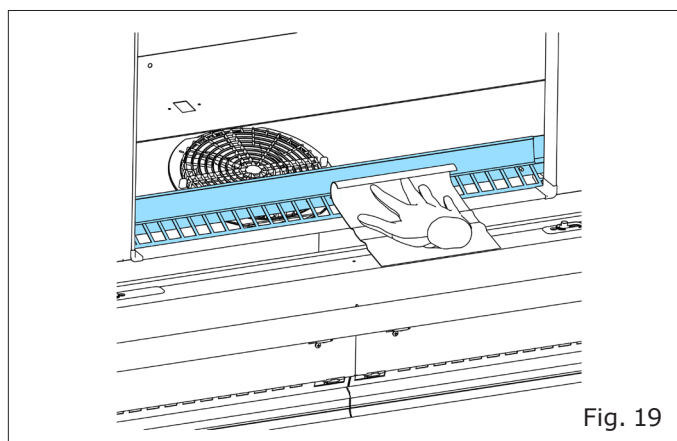

Fig. 19



Fare attenzione alle ventole dell'evaporatore! Non toccarle con le dita, stracci o altri utensili.

Modello - Modèle - Model Modell - Modelo - Modelo	GRANBERING INTEGRAL ULTRA	COSTAN eptarefrigeration
Fabbricante - Constructeur - Manufacturer Hersteller - Fabricante - Fabricante	Epta Spa - Via Mecenate, 86 - 20138 Milano (MI) ITALIA Tel. 02/55403211 Telefax 02/55401023	10/11

Cleaning instruction

IT
FR
EN
DE
ES
PT

- Pulire il piano di fondo con sapone neutro o detergente in acqua tiepida. Controllare che lo scarico non sia ostruito.
- Reinstallare la griglia di ripresa d'aria.

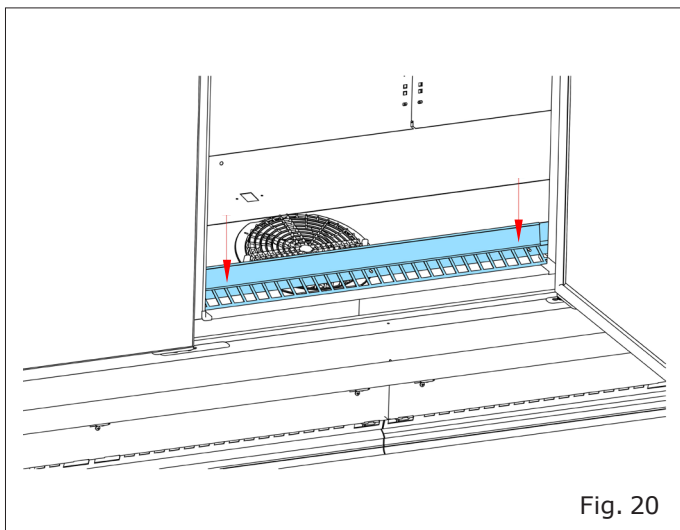

Fig. 20

- Reinstallare il piano di fondo.

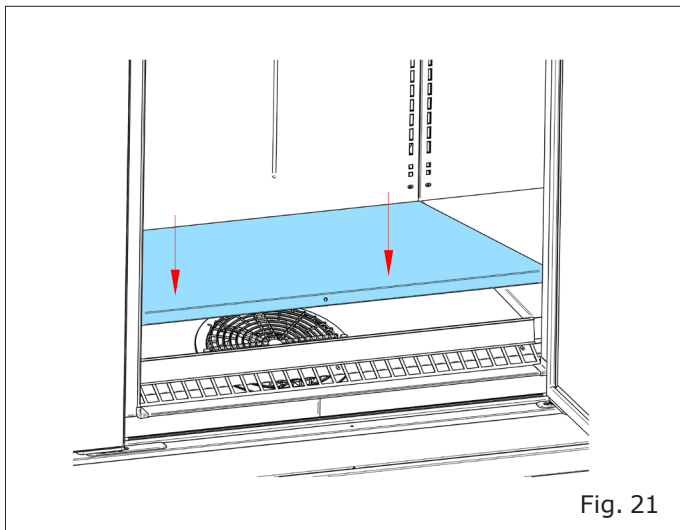

Fig. 21

- Reinstallare il cestone come descritto nel capitolo "Rimuovere il cestone".

3.5 Pulizia del condensatore

- Rimuovere le coperture del condensatore.

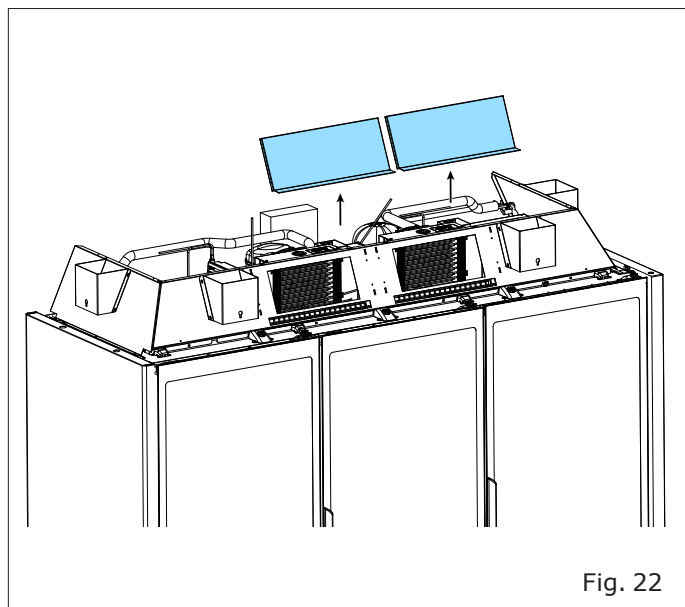

Fig. 22

- Pulire il condensatore con un aspiratore industriale o con una spazzola.

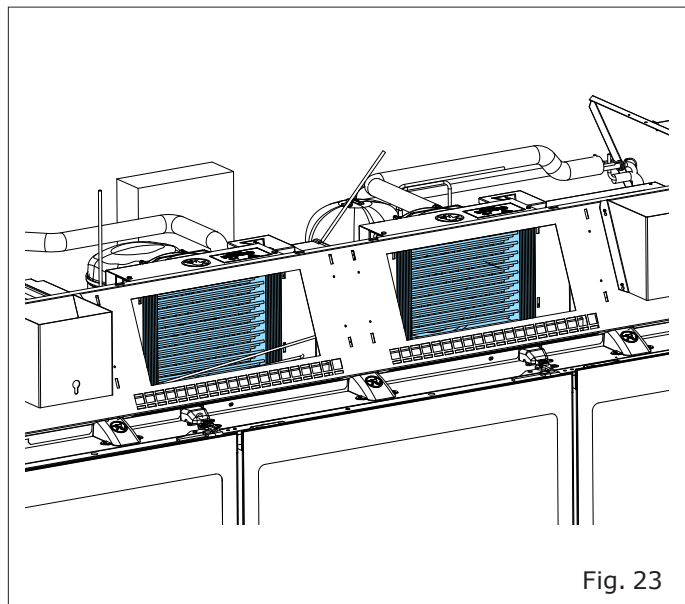

Fig. 23

Modello - Modèle - Model Modell - Modelo - Modelo	GRANBERING INTEGRAL ULTRA	COSTAN eptarefrigeration
Fabbricante - Constructeur - Manufacturer Hersteller - Fabricante - Fabricante	Epta Spa - Via Mecenate, 86 - 20138 Milano (MI) ITALIA Tel. 02/55403211 Telefax 02/55401023	11/11

3.6 Pulizia della bacinella di raccolta dell'acqua

- Rimuovere la copertura anteriore facendo leva.
- Scollegare il cavo di alimentazione.

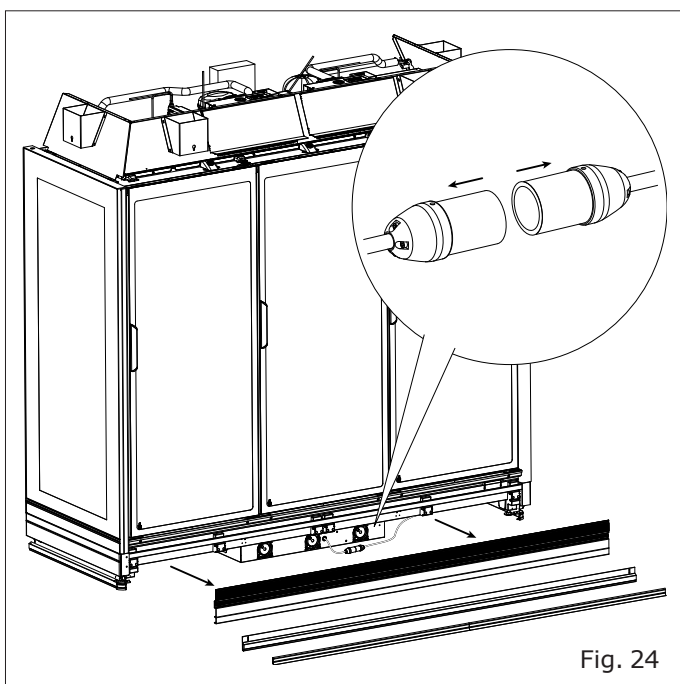

Fig. 24

- Estrarre la vaschetta.

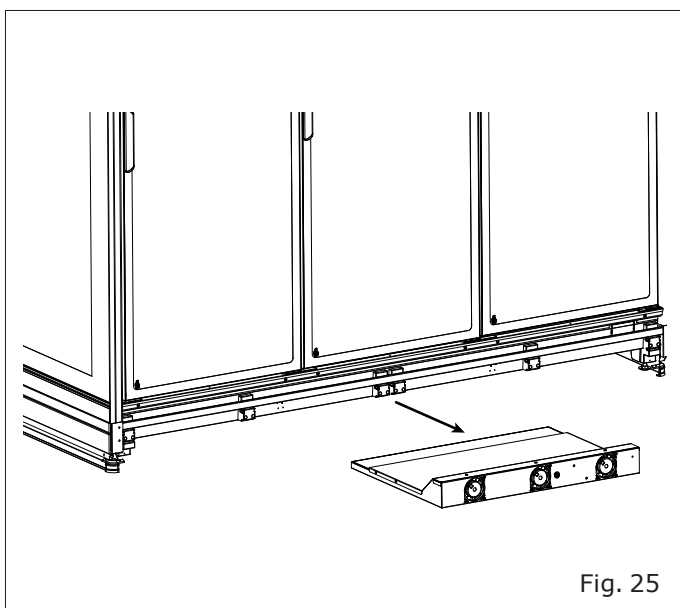

Fig. 25

- Svitare le viti e rimuovere il pannello superiore.
- Pulire la vaschetta.

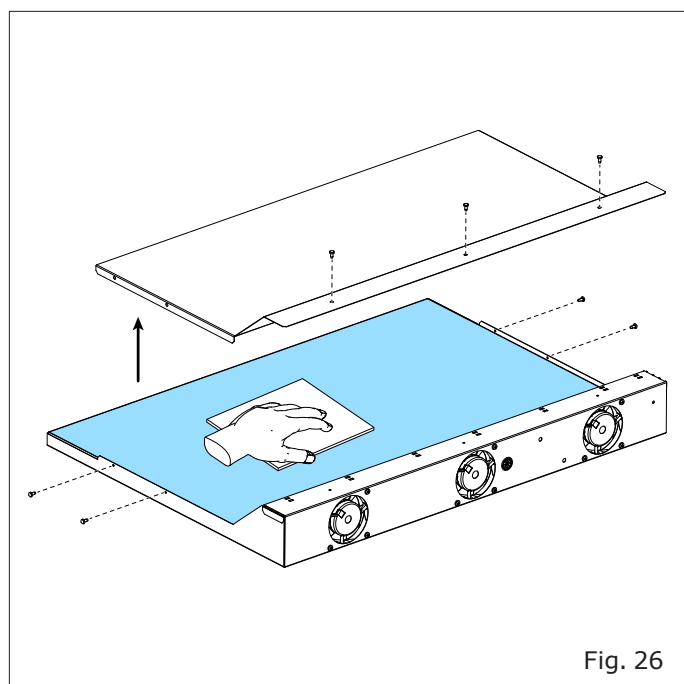

Fig. 26

3.7 Riaccensione del banco

- Dopo aver completato la pulizia e verificato attentamente che l'interno del banco sia completamente asciutto, rimettere in funzione il banco ripristinando l'alimentazione.
- Il banco inizierà il ciclo di raffreddamento. Far raggiungere una temperatura di -18°C prima di ricaricare la merce.

IT

FR

EN

DE

ES

PT

Modello - Modèle - Model Modell - Modelo - Modelo	GRANBERING INTEGRAL ULTRA	COSTAN <small>eptarefrigeration</small>
Fabbricante - Constructeur - Manufacturer Hersteller - Fabricante - Fabricante	Epta Spa - Via Mecenate, 86 - 20138 Milano (MI) ITALIA Tel. 02/55403211 Telefax 02/55401023	2/11

Cleaning instruction

TABLE DES MATIÈRES

IT

FR

EN

DE

ES

PT

1. Introduction	3
1.1 Périmètre	3
1.2 Informations générales de Sécurité	3
1.3 Pourquoi nettoyer	3
2. Produits de nettoyage	4
3. Nettoyage du meuble	5
3.1 Nettoyage des parties extérieures du meuble frigorifique de vente	5
3.2 Nettoyage de l'intérieur du meuble frigorifique de vente	5
3.3 Retrait du panier	6
3.4 Nettoyage du bac de fond (cuve)	9
3.5 Nettoyage du condenseur	10
3.6 Nettoyage du bac de récupération d'eau	11
3.7 Redémarrage du meuble	11

SYMBOLOGIE UTILISÉE



Symbole d'interdiction: interdiction d'effectuer certaines opérations.



Symbole d'attention: normes anti-accident pour l'opérateur.



Symbole d'avertissement: risque d'endommager le meuble réfrigéré et/ou ses composants.



Symbole de remarque: fourniture d'informations utiles.

Équipement de protection individuelle

	Chaussures de sécurité
	Gants de protection
	Lunettes de protection
	Casque de sécurité
	Gilet réfléchissant

Modello - Modèle - Model Modell - Modelo - Modelo	GRANBERING INTEGRAL ULTRA	COSTAN <small>eptarefrigeration</small>
Fabbricante - Constructeur - Manufacturer Hersteller - Fabricante - Fabricante	Epta Spa - Via Mecenate, 86 - 20138 Milano (MI) ITALIA Tel. 02/55403211 Telefax 02/55401023	3/11

1. INTRODUCTION

1.1 Périmètre

Le document « Cleaning instruction » indique comment nettoyer un présentoir de produits réfrigérés pour aliments surgelés.

Ces instructions sont aussi disponibles sur : www.eptarefrigeration.com.

1.2 Informations générales de Sécurité



Ne jamais interrompre la chaîne du froid des denrées exposées !



Avant d'entreprendre toute opération d'entretien ou de nettoyage, débrancher l'appareil de l'alimentation électrique et le protéger contre tout branchement par des personnes non autorisées.



S'assurer que la zone de travail est suffisamment éclairée pendant les activités de maintenance et de nettoyage et utiliser une source d'éclairage supplémentaire si nécessaire.



Les portes et les parois vitrées sont pourvues d'un film intérieur antibuée. Ne pas utiliser de détergent contenant des substances abrasives, fortement acides ou caustiques.



Attention à ne pas toucher les pièces en rotation du meuble (ventilateurs) avec les doigts, des serviettes ou d'autres outils.



Ne pas retirer les protections ni les couvercles.

1.3 Pourquoi nettoyer

Afin de présenter les produits et denrées de façon attrayante et hygiénique, il est important de nettoyer régulièrement le meuble réfrigéré. Un nettoyage régulier empêche également les moisissures et les bactéries nocives de s'installer dans le meuble, car la poussière humide constitue un terrain de reproduction idéal.

Un nettoyage régulier est également essentiel pour le bon fonctionnement technique. C'est le seul moyen de garantir un échange thermique optimal et une bonne circulation de l'air dans le meuble.

IT

FR

EN

DE

ES

PT

Modello - Modèle - Model Modell - Modelo - Modelo	GRANBERING INTEGRAL ULTRA	COSTAN  <small>epta refrigeration</small>
Fabbricante - Constructeur - Manufacturer Hersteller - Fabricante - Fabricante	Epta Spa - Via Mecenate, 86 - 20138 Milano (MI) ITALIA Tel. 02/55403211 Telefax 02/55401023	4/11

Cleaning instruction

IT

2. PRODUITS DE NETTOYAGE

FR

Vêtements de travail

- Gants de protection
- Vêtements de protection
- Lunettes de protection

EN

DE

ES

Produits de nettoyage pour surfaces autres que vitrées

PT

- Eau
- Détergent doux
- Éponges, chiffons et chiffons doux, non abrasifs

Produits de nettoyage pour surfaces vitrées

- Eau
- Détergent doux
- Nettoyant à vitres standard
- Détachants pour taches d'huile
- Éponges, chiffons et serviettes en papier, non abrasifs.

Ne pas utiliser ce qui suit

- Produits de nettoyage fortement corrosifs
- Produits de nettoyage acides ou caustiques
- Produits inflammables
- Acétone
- Produits de nettoyage contenant des solvants
- Nettoyants abrasifs
- Nettoyant haute pression ou autre jet d'eau puissant pour nettoyer

Modello - Modèle - Model Modell - Modelo - Modelo	GRANBERING INTEGRAL ULTRA	COSTAN eptarefrigeration
Fabbricante - Constructeur - Manufacturer Hersteller - Fabricante - Fabricante	Epta Spa - Via Mecenate, 86 - 20138 Milano (MI) ITALIA Tel. 02/55403211 Telefax 02/55401023	5/11

3. NETTOYAGE DU MEUBLE

3.1 Nettoyage des parties extérieures du meuble frigorifique de vente

- Nettoyer les surfaces extérieures de la vitrine avec un savon doux ou un détergent dans de l'eau tiède uniquement.
- Essuyer soigneusement avec des éponges, des chiffons et des chiffons doux, non abrasifs.

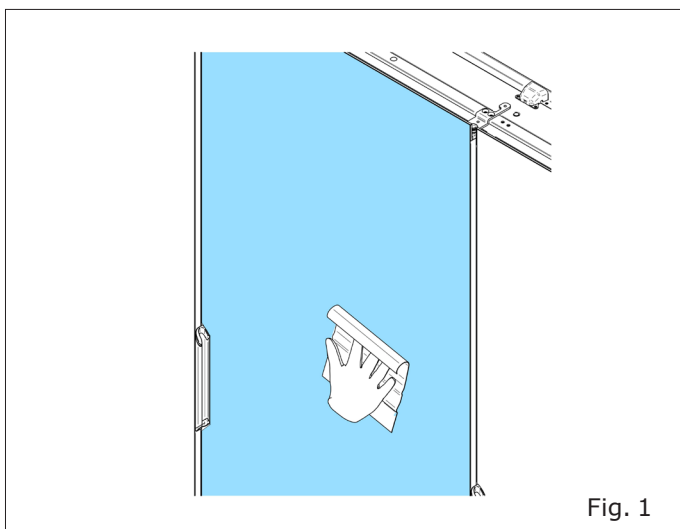

Nettoyage des portes et joues vitrées :

- Les nettoyer en utilisant un nettoyant pour vitres standard avec une éponge non abrasive, un chiffon ou une serviette en papier.

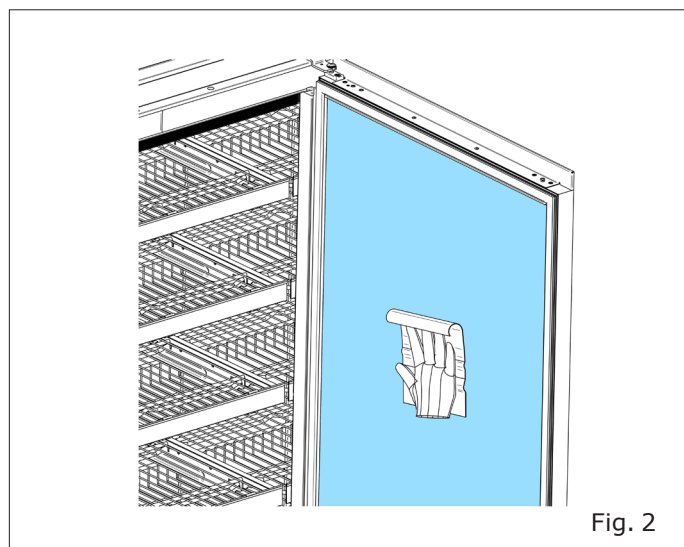

Les résidus graisseux doivent être éliminés à l'aide d'un détachant pour huile.

3.2 Nettoyage de l'intérieur du meuble frigorifique de vente

- Retirer les produits/denrées exposés dans les meubles frigorifiques de vente.
- Ne pas interrompre la chaîne du froid.
- Débrancher l'appareil de l'alimentation électrique et le protéger contre tout branchement par des personnes non autorisées.

Nettoyage des étagères :

- Les surfaces peuvent être nettoyées avec un savon doux ou un détergent dans de l'eau tiède.

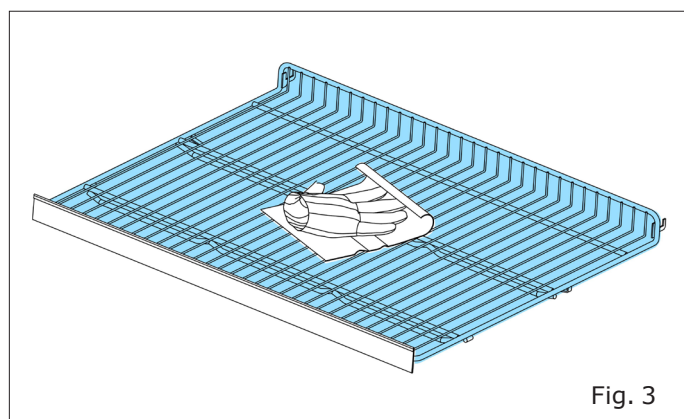

Modello - Modèle - Model Modell - Modelo - Modelo	GRANBERING INTEGRAL ULTRA	COSTAN eptarefrigeration
Fabbricante - Constructeur - Manufacturer Hersteller - Fabricante - Fabricante	Epta Spa - Via Mecenate, 86 - 20138 Milano (MI) ITALIA Tel. 02/55403211 Telefax 02/55401023	6/11

Cleaning instruction

IT

FR

EN

DE

ES

PT

- Pour faciliter le nettoyage, il est possible de détacher et retirer les étagères de la crémaillère.

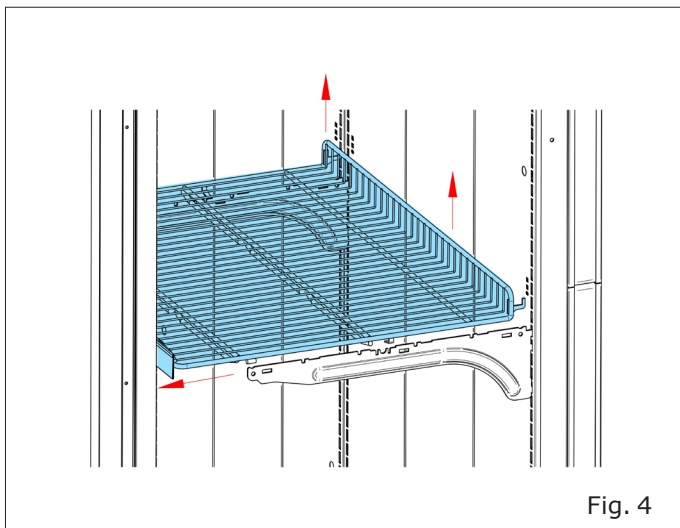

Fig. 4



Veillez faire pivoter l'étagère pour l'extraire de l'appareil.

- S'assurer que les bras d'étagères sont dans la bonne position et qu'ils se verrouillent complètement dans la crémaillère lorsqu'ils sont à nouveau fixés.

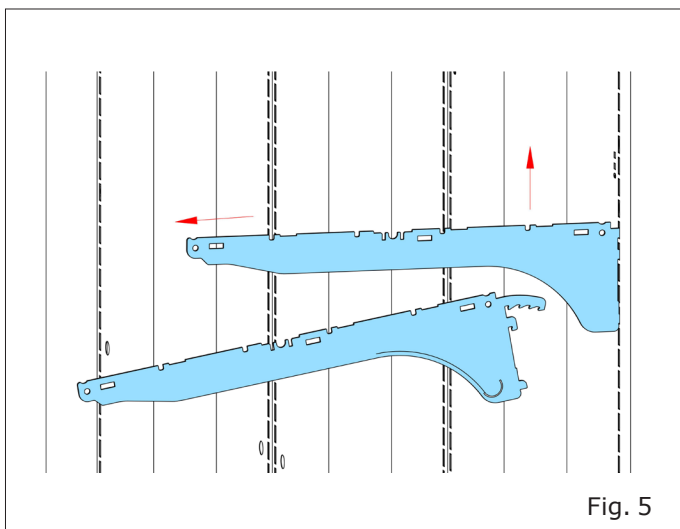

Fig. 5

Nettoyage du grilles de reprise

- Nettoyer les grilles de reprise à l'aide d'un aspirateur et/ou nettoyer les grilles à l'aide d'un chiffon humide.

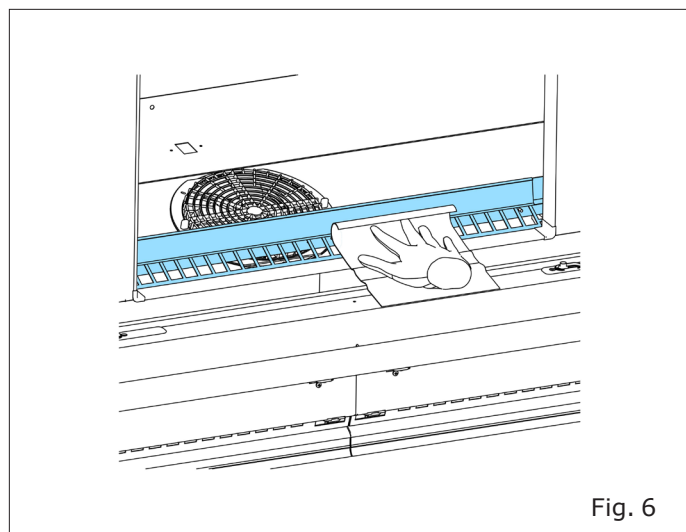

Fig. 6

3.3 Retrait du panier

- Le congélateur peut être fourni avec un panier coulissant.

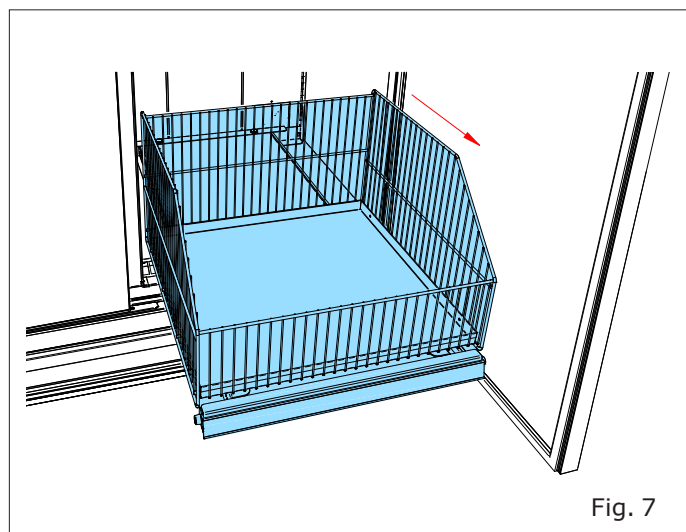
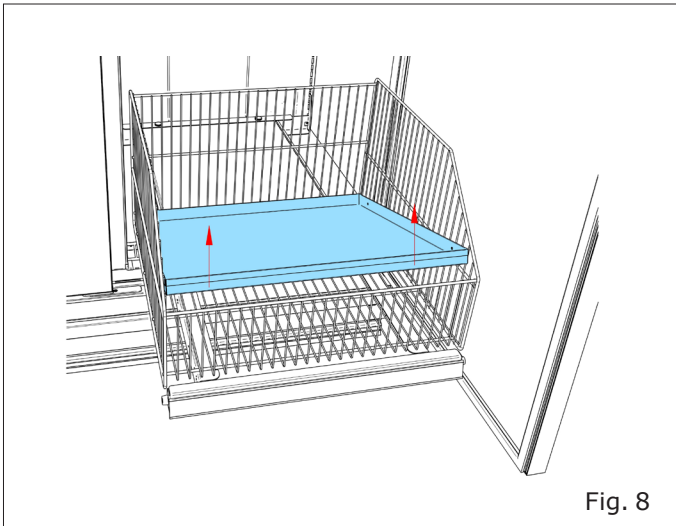
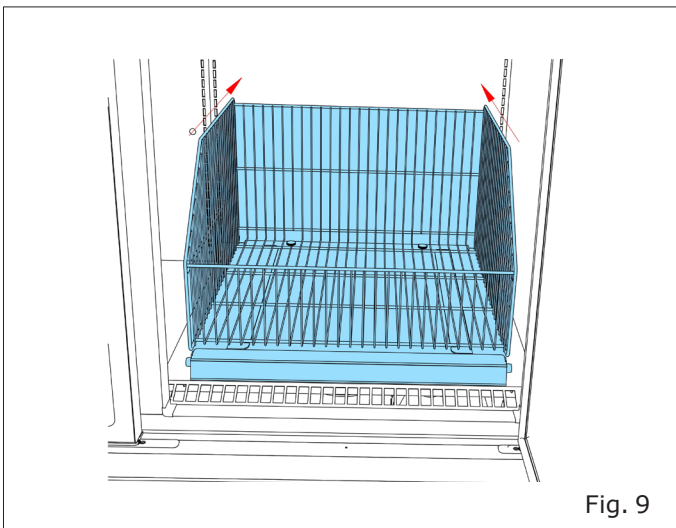

Fig. 7

- Il peut être retiré pour être nettoyé.
- Pour ce faire, sortez le panier de l'armoire et retirez les deux écrous moletés. Le panier peut alors être retiré.



Retirez le panneau intérieur.



Mettez le panier à l'intérieur pour retirer les écrous moletés.

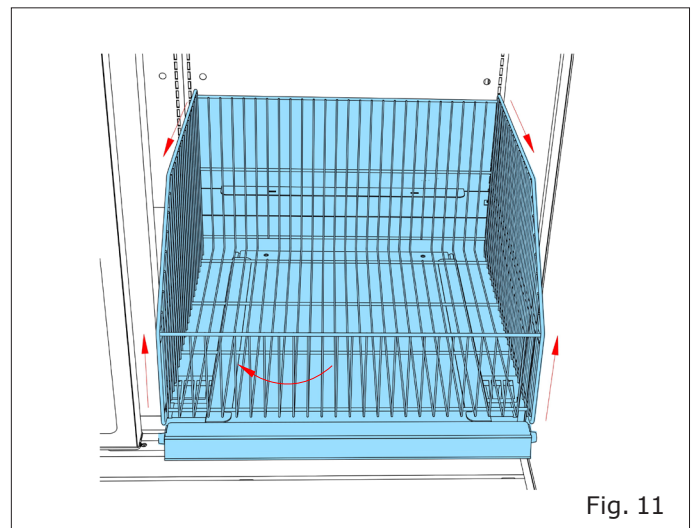
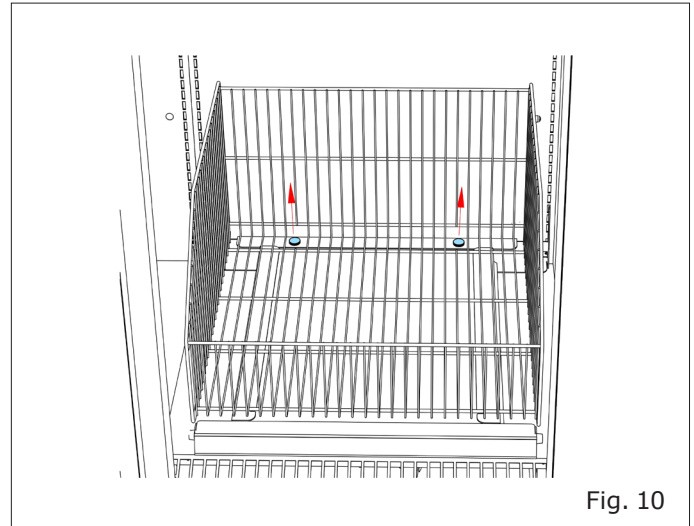

IT

FR

EN

DE

ES

PT

Modello - Modèle - Model Modell - Modelo - Modelo	GRANBERING INTEGRAL ULTRA	
Fabbricante - Constructeur - Manufacturer Hersteller - Fabricante - Fabricante	Epta Spa - Via Mecenate, 86 - 20138 Milano (MI) ITALIA Tel. 02/55403211 Telefax 02/55401023	8/11

Cleaning instruction

IT
FR
EN
DE
ES
PT

- Réinstallez le panier dans l'ordre inverse. Alignez le panier et fixez-le avec les écrous moletés.
- Rangez soigneusement les écrous moletés et remettez-les en place après le nettoyage pour fixer le panier.

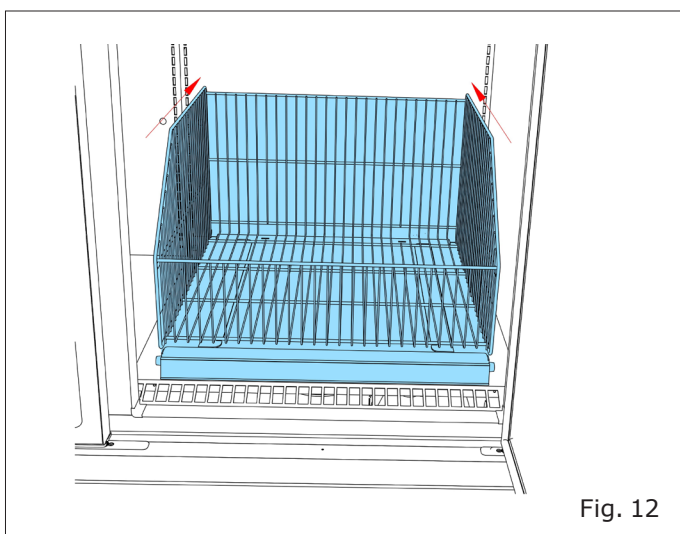

Fig. 12

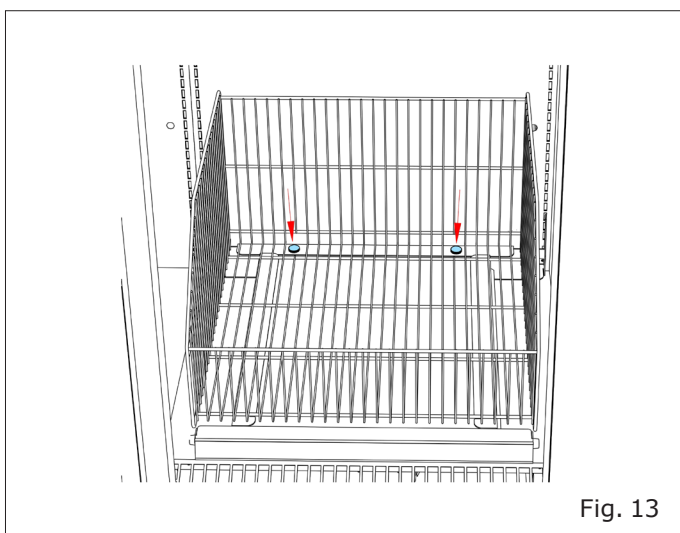

Fig. 13

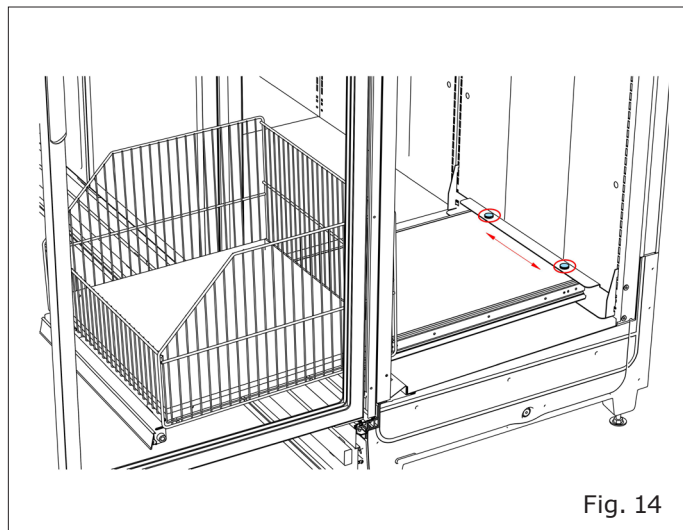

Fig. 14



Vérifiez soigneusement que le panier ne touche aucun cadre ou joint de la vitrine ou de la porte.

3.4 Nettoyage du bac de fond (cuve)



Le nettoyage du bac de fond ne doit être effectué que par du personnel qualifié.

- Retirer les produits/denrées exposés dans les meubles frigorifiques de vente.
- Ne pas interrompre la chaîne du froid.
- Débrancher l'appareil de l'alimentation électrique et le protéger contre tout branchement par des personnes non autorisées.
- Retirez le panier coulissant comme décrit au chapitre. "Retrait du panier".

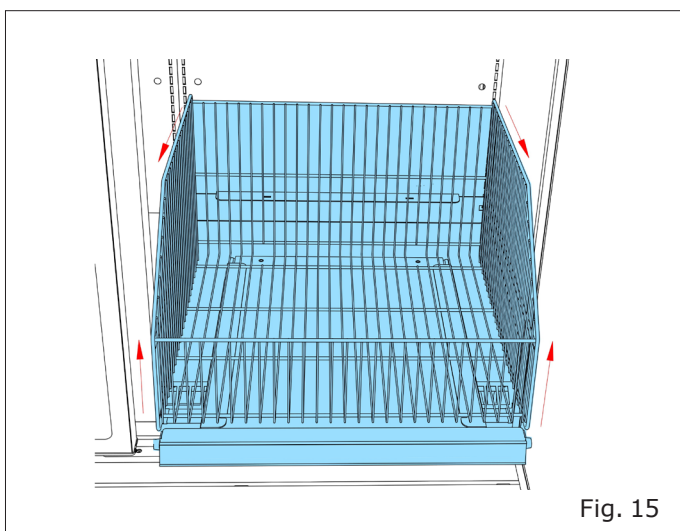

Fig. 15

- Nettoyer le bac de fond à l'aide d'un chiffon humide.

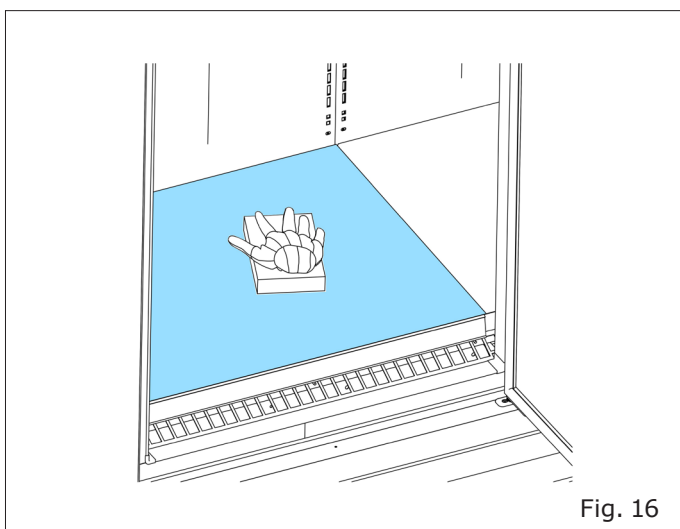

Fig. 16

- Enlevez-le.

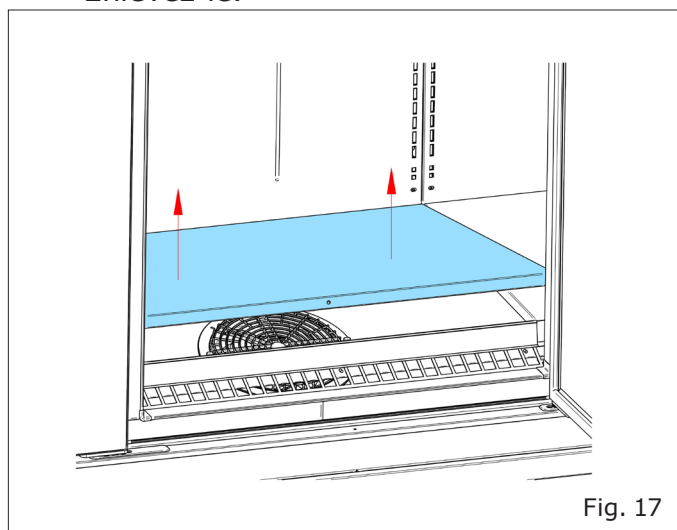

Fig. 17

- Retirer les grilles de reprise d'air et les souffler d'air et les nettoyer à l'aide d'un chiffon humide.

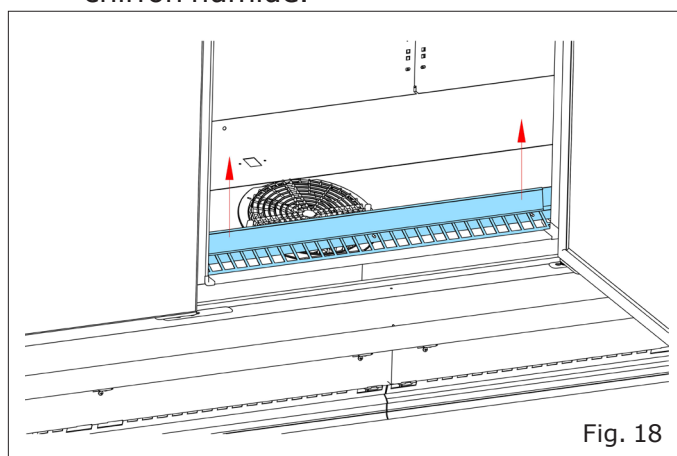

Fig. 18

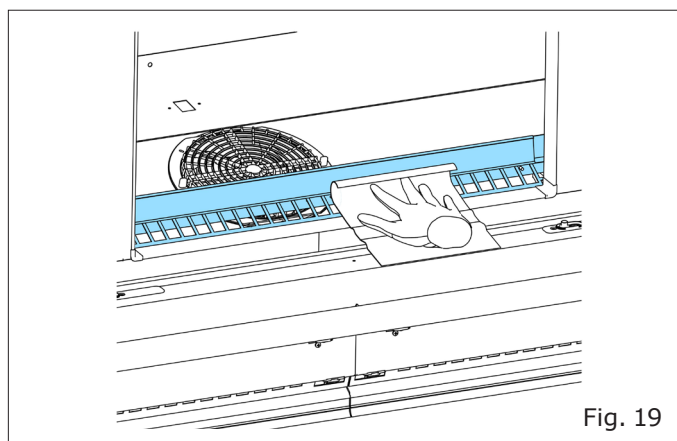

Fig. 19



ATTENTION AUX VENTILATEURS D'EVAPORATEURS EN ROTATION ! NE LES TOUCHEZ PAS AVEC LES DOIGTS, CHIFFONS OU D'AUTRES OUTILS !

Modello - Modèle - Model Modell - Modelo - Modelo	GRANBERING INTEGRAL ULTRA	
Fabbricante - Constructeur - Manufacturer Hersteller - Fabricante - Fabricante	Epta Spa - Via Mecenate, 86 - 20138 Milano (MI) ITALIA Tel. 02/55403211 Telefax 02/55401023	10/11

Cleaning instruction

IT
FR
EN
DE
ES
PT

- Nettoyer le bac de fond avec un savon ou un détergent doux dans de l'eau tiède. Vérifier que le siphon n'est pas bouché.
- Réinstaller les grilles de reprise.

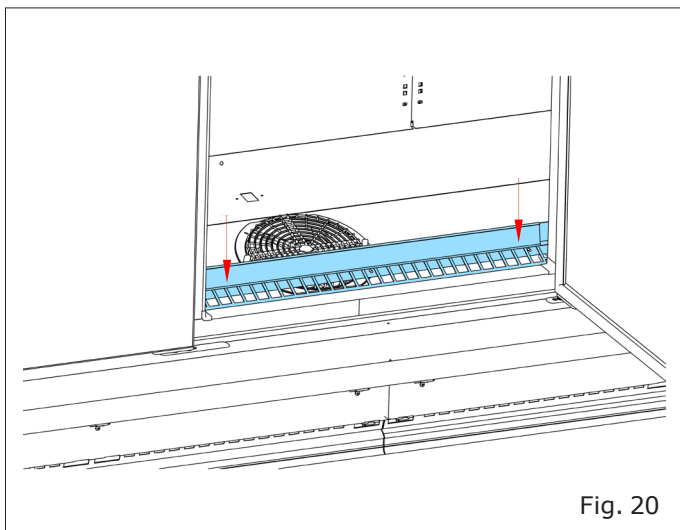

Fig. 20

- Réinstaller le plateau de cuve.

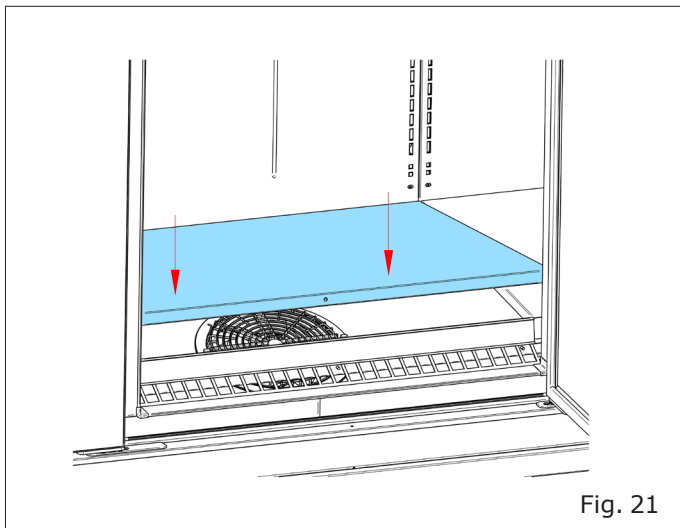

Fig. 21

- Réinstaller le panier comme décrit dans le chapitre "Retrait du panier".

3.5 Nettoyage du condenseur

- Retirez les couvercles du condenseur.

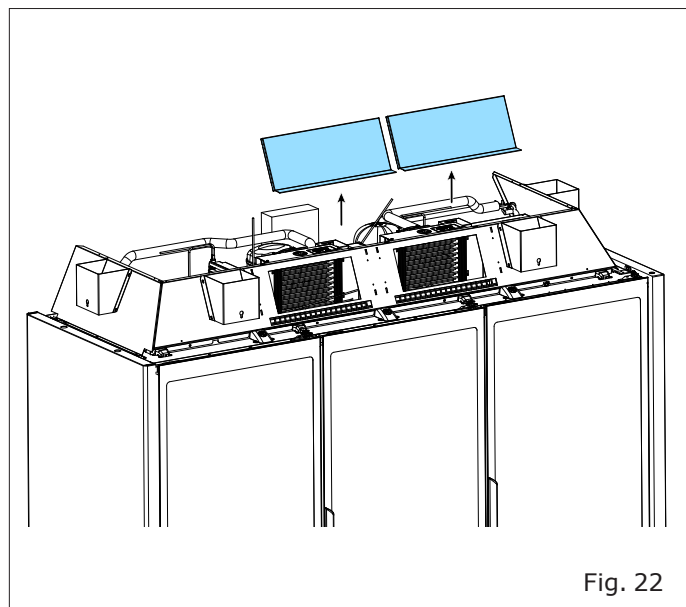

Fig. 22

- Nettoyer le condenseur avec un aspirateur industriel ou une brosse à main.

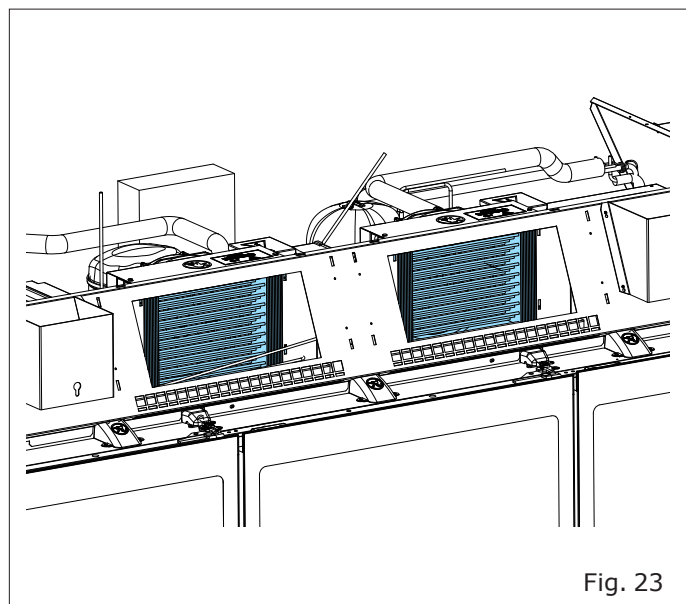
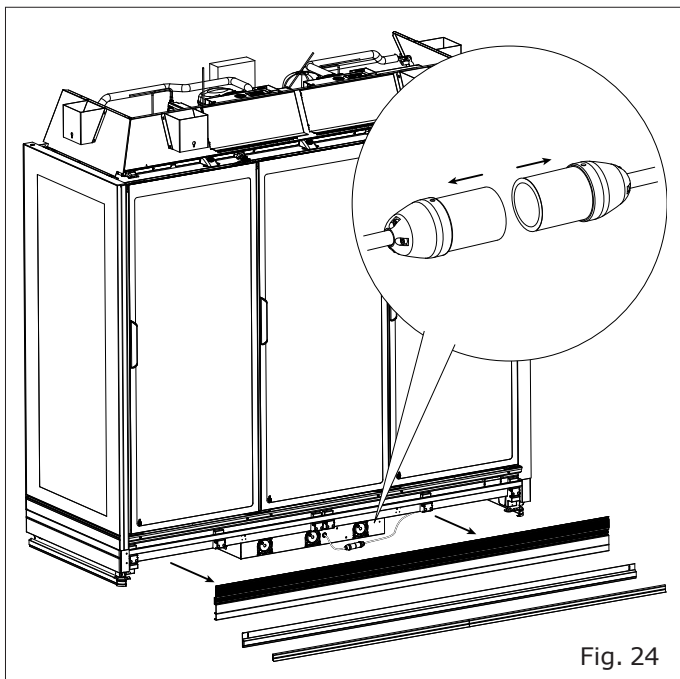

Fig. 23

Modello - Modèle - Model Modell - Modelo - Modelo	GRANBERING INTEGRAL ULTRA	COSTAN eptarefrigeration
Fabbricante - Constructeur - Manufacturer Hersteller - Fabricante - Fabricante	Epta Spa - Via Mecenate, 86 - 20138 Milano (MI) ITALIA Tel. 02/55403211 Telefax 02/55401023	11/11

3.6 Nettoyage du bac de récupération d'eau

- Retirez le capot avant en le soulevant.
- Débrancher le câble d'alimentation.



- Retirez le bac à eau.

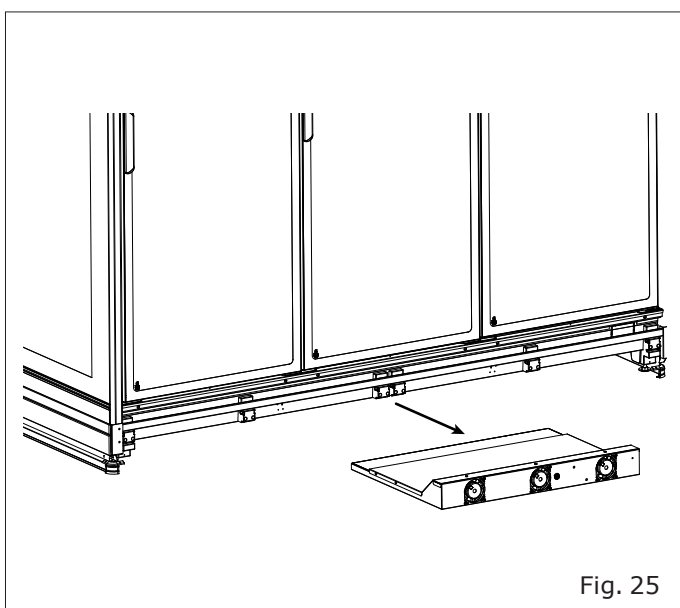

- Dévissez les vis et retirez le panneau supérieur.
- Nettoyez le bac à eau.

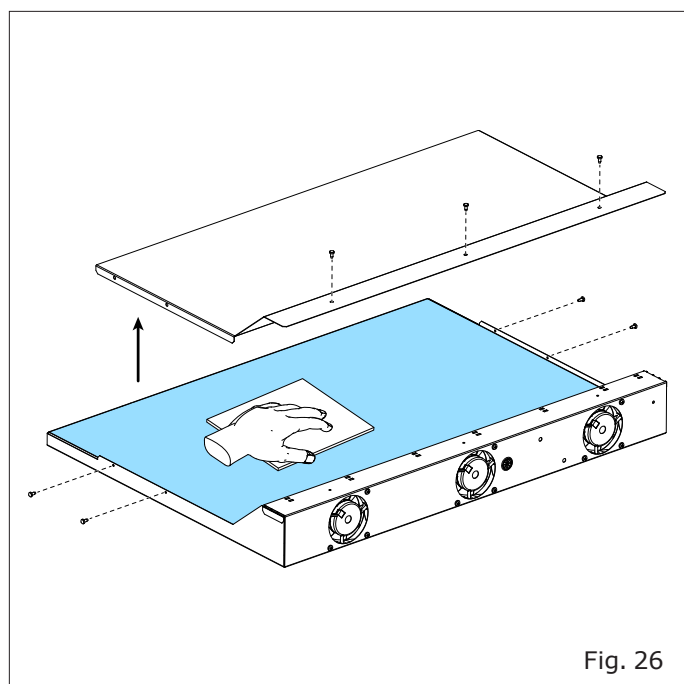

3.7 Redémarrage du meuble

- Après avoir terminé le nettoyage et vérifié attentivement que l'intérieur du meuble est complètement sec, remettre l'appareil en service en rebranchant l'alimentation électrique du meuble.
- Le meuble commencera alors son cycle de refroidissement. Laisser les meubles atteindre une température affichée de -18°C avant de recharger les denrées/ produits retirés.

Modello - Modèle - Model Modell - Modelo - Modelo	GRANBERING INTEGRAL ULTRA	COSTAN <small>eptarefrigeration</small>
Fabbricante - Constructeur - Manufacturer Hersteller - Fabricante - Fabricante	Epta Spa - Via Mecenate, 86 - 20138 Milano (MI) ITALIA Tel. 02/55403211 Telefax 02/55401023	2/11

Cleaning instruction

VERZEICHNIS

IT

FR

EN

DE

ES

PT

1. Einführung	3
1.1 Der Zweck dieses Dokuments	3
1.2 Allgemeine Sicherheitshinweise	3
1.3 Gründe für eine Reinigung	3
2. Reinigungsmittel	4
3. Reinigung der Kühlmöbel	5
3.1 Reinigung der Außenflächen der Kühlmöbel	5
3.2 Reinigung des Kühlmöbel-Innenraums	5
3.3 Herausnehmen des Korbes	6
3.4 Reinigung der Auslagefläche	9
3.5 Reinigung des Kondensators	10
3.6 Reinigung der Wasserauffangschale	11
3.7 Neustart des Kühlmöbels	11

VERWENDETE SYMBOLE



Symbol für ein Verbot: Verbieta bestimmte Handlungen.



Gefahrensymbol: Regeln zur Unfallvermeidung für den Benutzer.



Symbol für einen Warnhinweis: Möglicherweise kann ein Schaden am Gerät und/oder an einer der Komponenten entstehen.



Symbol für einen Hinweis: Es folgen nützliche Informationen.

Persönliche Schutzausrüstung

	Sicherheitsschuhe
	Schutzhandschuhe
	Schutzbrille
	Schutzhelm
	Sicherheitswesten

Modello - Modèle - Model Modell - Modelo - Modelo	GRANBERING INTEGRAL ULTRA	COSTAN <small>eptarefrigeration</small>
Fabbricante - Constructeur - Manufacturer Hersteller - Fabricante - Fabricante	Epta Spa - Via Mecenate, 86 - 20138 Milano (MI) ITALIA Tel. 02/55403211 Telefax 02/55401023	3/11

1. EINFÜHRUNG

1.1 Der Zweck dieses Dokuments

Das Dokument „Cleaning Instructions“ zeigt, wie eine Vitrine mit gekühlten Produkten für gefrorene Lebensmittel gereinigt wird.

Die Bedienungsanleitung ist auch unter verfügbar:
www.eptarefrigeration.com.

1.2 Allgemeine Sicherheitshinweise



Die Kühlkette der gekühlten Waren darf keinesfalls unterbrochen werden.



Trennen Sie das Gerät vom Stromnetz, bevor Sie Wartungs- oder Reinigungsarbeiten durchführen und stellen Sie sicher, dass die Stromzufuhr keinesfalls durch unbefugte Personen wieder eingeschaltet wird.



Stellen Sie sicher, dass der Arbeitsbereich während der Wartungs- und Reinigungsarbeiten ausreichend beleuchtet ist, und schalten Sie, falls erforderlich, eine zusätzliche Lichtquelle ein.



Die Türen und Glaswände sind von innen mit einer Antibeschlagfolie ausgerüstet. Verwenden Sie keine Scheuermittel oder Reinigungsmittel, die stark säurehaltige oder ätzende Substanzen enthalten.



Achten Sie darauf, mit den Fingern, Handtüchern oder anderen Werkzeugen keine rotierenden Geräteteile (Lüfter) zu berühren.



Entfernen Sie keine oder Schutzvorrichtungen oder Abdeckungen.

1.3 Gründe für eine Reinigung

Damit die Waren auf attraktive und hygienische Weise präsentiert werden, ist eine regelmäßige Reinigung des Kühlmöbels unverzichtbar. Eine regelmäßige Reinigung verhindert außerdem, dass sich Schimmel und schädliche Bakterien auf den Oberflächen ansiedeln, denn für sie bietet feuchter Staub einen idealen Nährboden.

Auch für den reibungslosen Betrieb der technischen Komponenten ist eine regelmäßige Reinigung entscheidend, denn nur dann ist gewährleistet, dass ein optimaler Wärmeaustausch stattfindet und die Luft im Kühlmöbel ungehindert zirkulieren kann.

IT

FR

EN

DE

ES

PT

Modello - Modèle - Model Modell - Modelo - Modelo	GRANBERING INTEGRAL ULTRA	COSTAN  <small>eptarefrigeration</small>
Fabbricante - Constructeur - Manufacturer Hersteller - Fabricante - Fabricante	Epta Spa - Via Mecenate, 86 - 20138 Milano (MI) ITALIA Tel. 02/55403211 Telefax 02/55401023	4/11

Cleaning instruction

IT 2. REINIGUNGSMITTEL

FR

Arbeitskleidung

- Schutzhandschuhe
- Schutzkleidung
- Schutzbrille

EN

DE

ES

Reinigungsmittel für andere Oberflächen als Glas

PT

- Wasser
- Mildes Reinigungsmittel
- Weiche Schwämme, Lappen und Tücher
(ohne raue Oberflächen)

Reinigungsmittel für Glasflächen

- Wasser
- Mildes Reinigungsmittel
- Handelsübliche Glasreiniger
- Ölfleckenentferner
- Weiche Schwämme, Lappen (ohne raue
Oberflächen) und Papiertücher

Die folgenden Mittel dürfen nicht eingesetzt werden:

- Stark korrosionsfördernde
Reinigungsmittel
- Säurehaltige oder ätzende
Reinigungsmittel
- Entflammbare Stoffe
- Azeton
- Lösungsmittelhaltige Reinigungsmittel
- Scheuermittel
- Hochdruckreiniger oder ein anderer
starker Wasserstrahl zur Reinigung

Modello - Modèle - Model Modell - Modelo - Modelo	GRANBERING INTEGRAL ULTRA	COSTAN eptarefrigeration
Fabbricante - Constructeur - Manufacturer Hersteller - Fabricante - Fabricante	Epta Spa - Via Mecenate, 86 - 20138 Milano (MI) ITALIA Tel. 02/55403211 Telefax 02/55401023	5/11

3. REINIGUNG DER KÜHLMÖBEL

3.1 Reinigung der Außenflächen der Kühlmöbel

- Geben Sie für die Reinigung der Außenflächen der Kühlmöbel etwas Seife oder Reinigungsmittel in lauwarmes Wasser.
- Wischen Sie die Oberflächen vorsichtig ab, verwenden Sie dafür einen Schwamm oder Lappen ohne raue Oberfläche bzw. ein weiches Tuch.

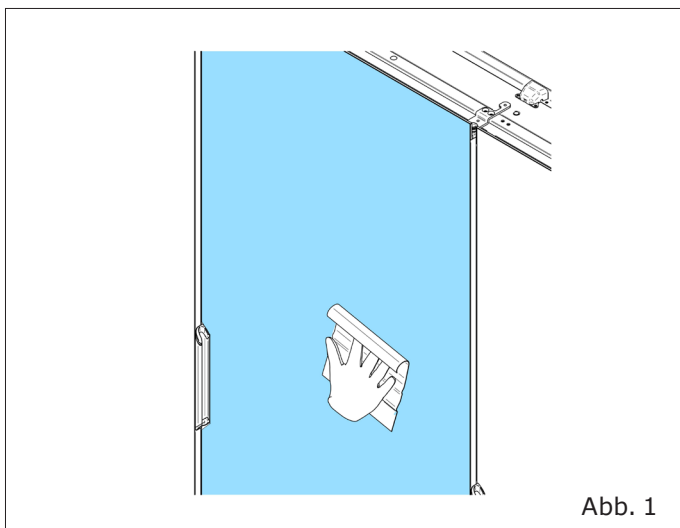

Reinigung der Glastüren und der Glaswände im Innenraum:

- Verwenden Sie einen handelsüblichen Glasreiniger und einen Schwamm oder Lappen ohne raue Oberflächen bzw. ein Papiertuch.

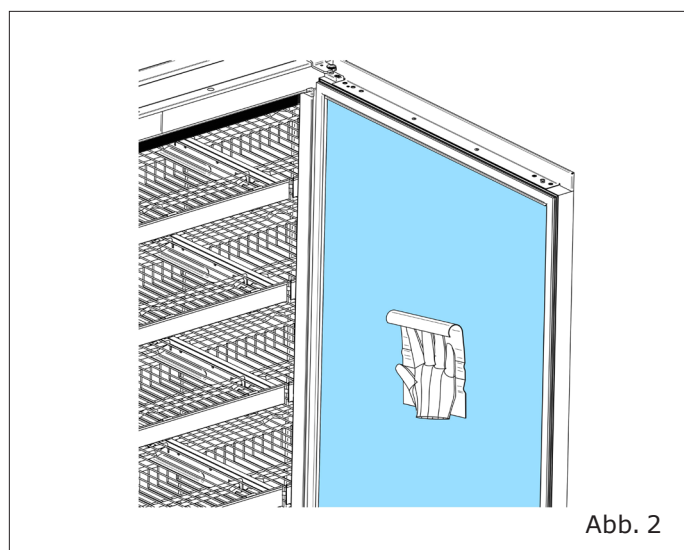

 Fettige Rückstände müssen mit Ölfleckenentferner beseitigt werden.

3.2 Reinigung des Kühlmöbel-Innenraums

- Legen Sie die Waren in eine Tiefkühlschränke oder gekühlte Tiefkühlräume.
- Vermeiden Sie eine Unterbrechung der Kühlkette.
- Trennen Sie das Gerät vom Stromnetz und stellen Sie sicher, dass der Strom keinesfalls durch unbefugte Personen wieder eingeschaltet wird.

Reinigung der Einlegeböden:

- Geben Sie für die Reinigung der Oberflächen etwas Seife oder Spülmittel in lauwarmes Wasser.

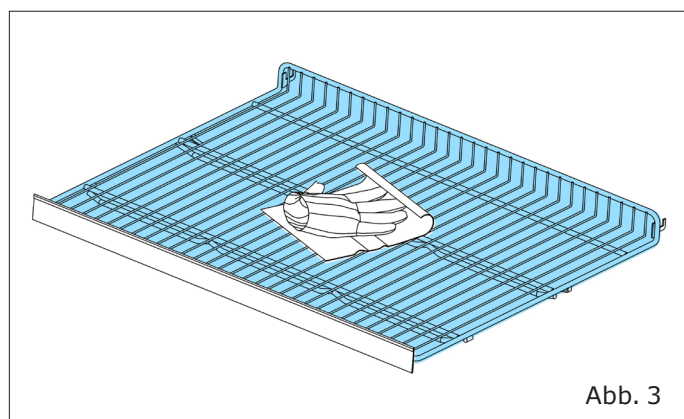

Modello - Modèle - Model Modell - Modelo - Modelo	GRANBERING INTEGRAL ULTRA	COSTAN eptarefrigeration
Fabbricante - Constructeur - Manufacturer Hersteller - Fabricante - Fabricante	Epta Spa - Via Mecenate, 86 - 20138 Milano (MI) ITALIA Tel. 02/55403211 Telefax 02/55401023	6/11

Cleaning instruction

IT
FR
EN
DE
ES
PT

- Zur bequemen Reinigung können Sie die Einlegeböden aus dem Regal herausnehmen.



Abb. 4



Bitte drehen Sie das Regal, um es aus dem Schrank zu nehmen.

- Vergewissern Sie sich, dass sich die Halterungen in der richtigen Position befinden und beim erneuten Einsetzen vollständig in den Trägern einrasten.

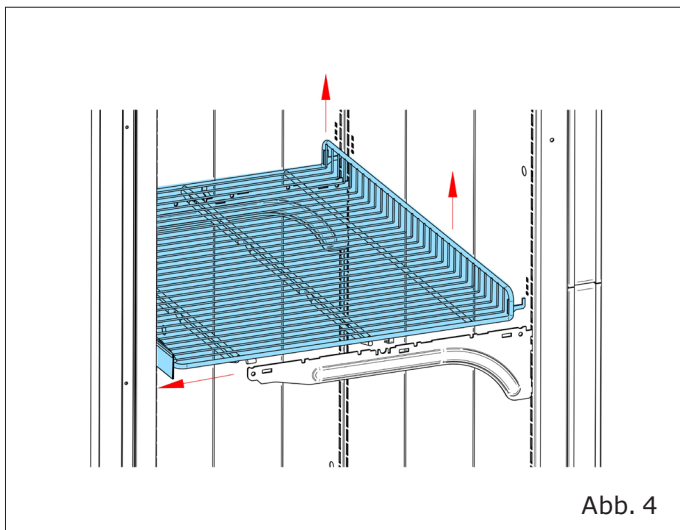

Abb. 5

Reinigung der Lüftungsgitter

- Reinigen Sie die Einlassgitter mit einem Staubsauger und/oder reinigen Sie die Gitter mit einem feuchten Tuch.

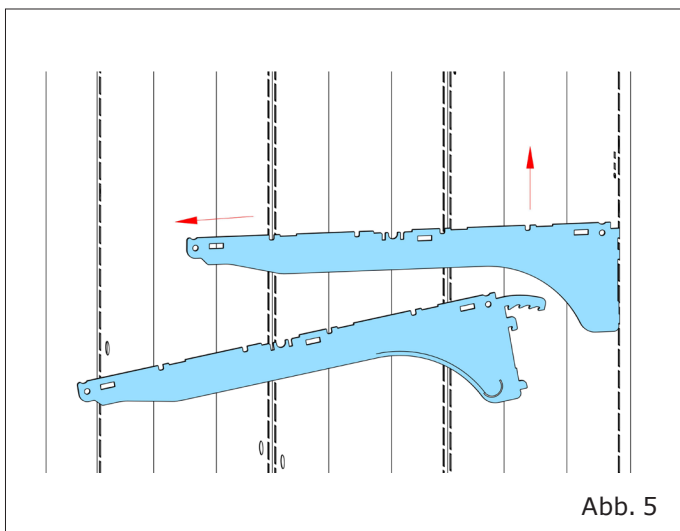

Abb. 6

3.3 Herausnehmen des Korbes

- Die Tiefkühltruhe kann mit einem ausziehbaren Korb geliefert werden.

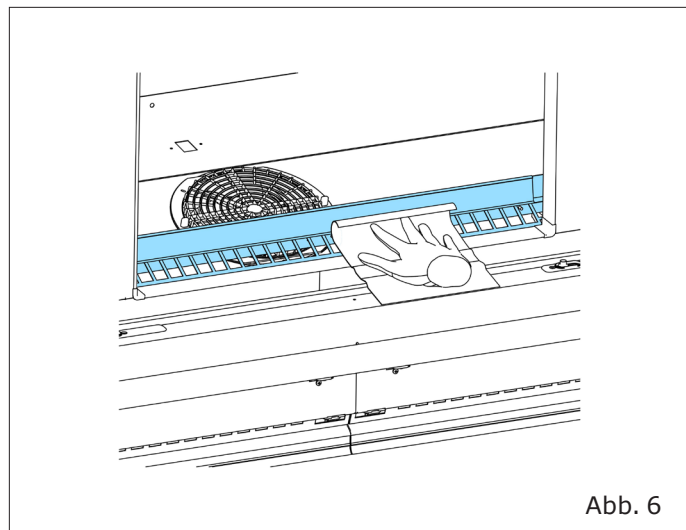

Abb. 7

- Diese kann zur Reinigung entfernt werden.
- Ziehen Sie dazu den Korb aus dem Gehäuse heraus und entfernen Sie die beiden Rändelmutter. Der Korb kann dann herausgenommen werden.



Entfernen Sie die innere Platte.

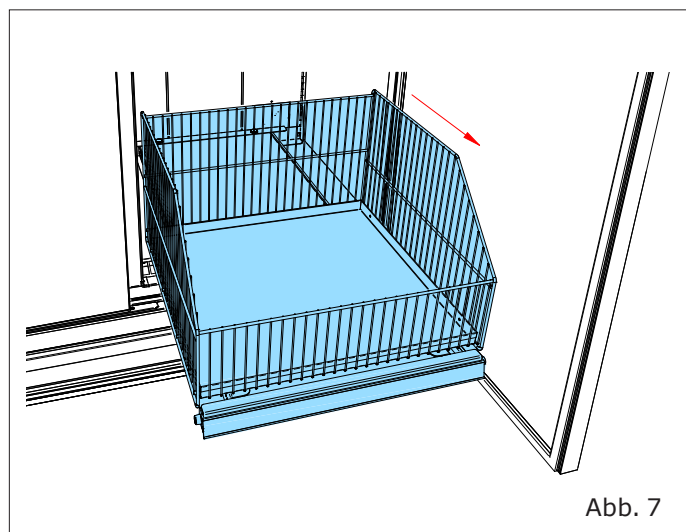
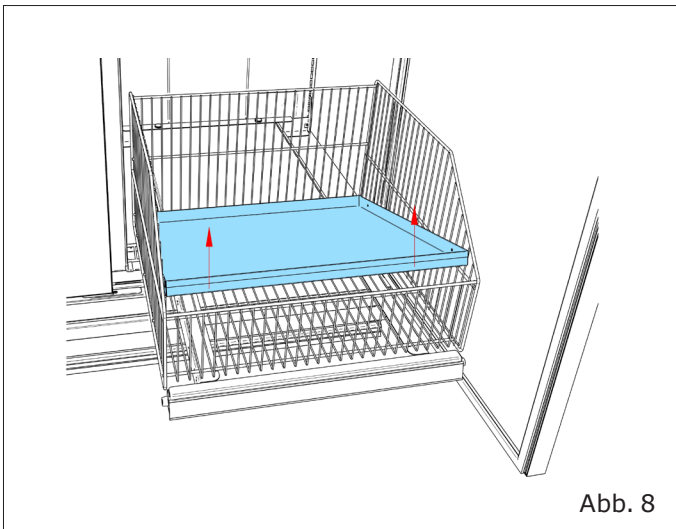
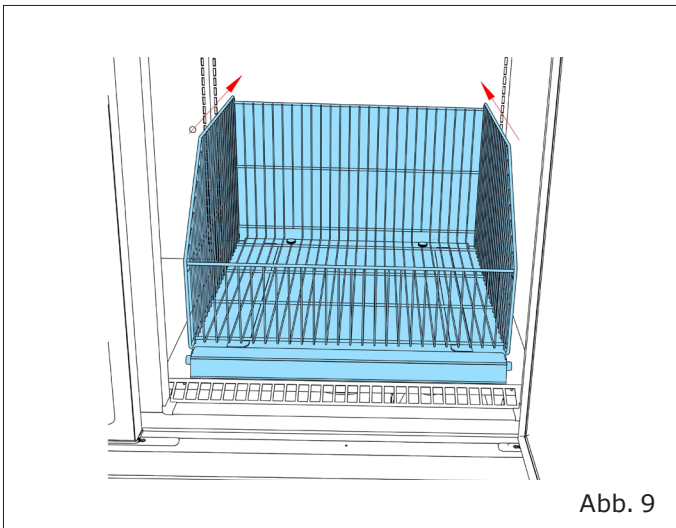

Legen Sie den Korb hinein, um die Rändelmutter zu entfernen.

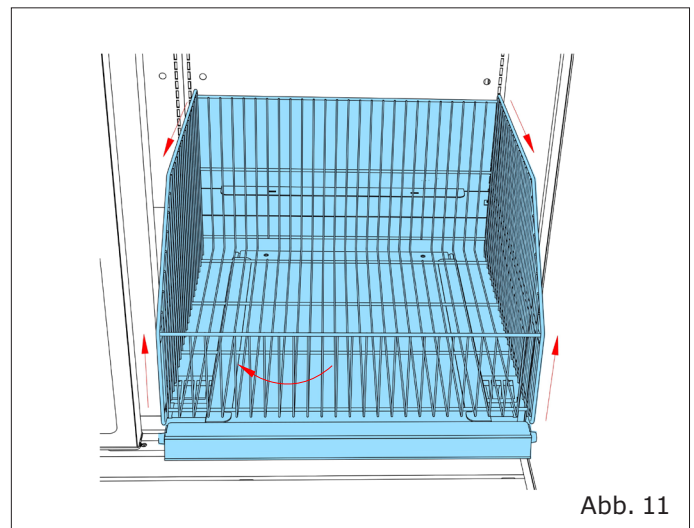
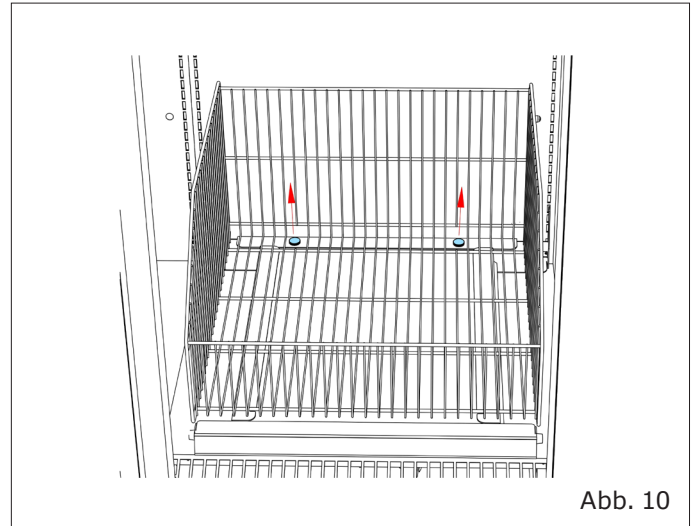

IT

FR

EN

DE

ES

PT

Modello - Modèle - Model Modell - Modelo - Modelo	GRANBERING INTEGRAL ULTRA	COSTAN eptarefrigeration
Fabbricante - Constructeur - Manufacturer Hersteller - Fabricante - Fabricante	Epta Spa - Via Mecenate, 86 - 20138 Milano (MI) ITALIA Tel. 02/55403211 Telefax 02/55401023	8/11

Cleaning instruction

IT
FR
EN
DE
ES
PT

- Setzen Sie den Korb in umgekehrter Reihenfolge wieder ein. Richten Sie den Korb aus und befestigen Sie ihn mit den Rändelmuttern.
- Bewahren Sie die Rändelmuttern sorgfältig auf und setzen Sie sie nach der Reinigung wieder ein, um den Korb zu befestigen.

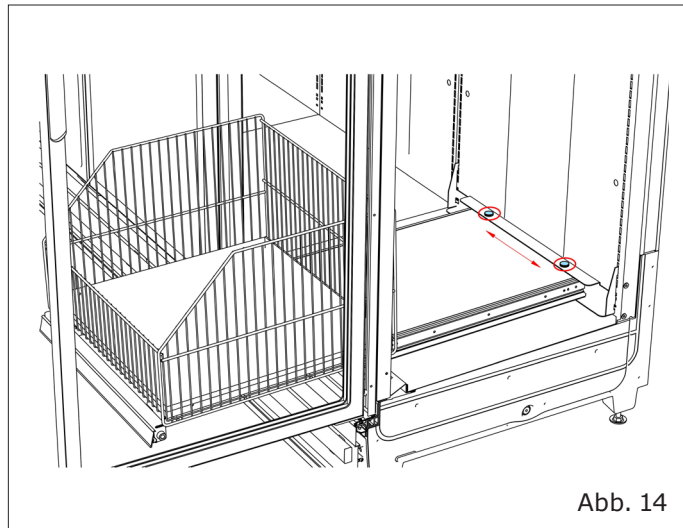
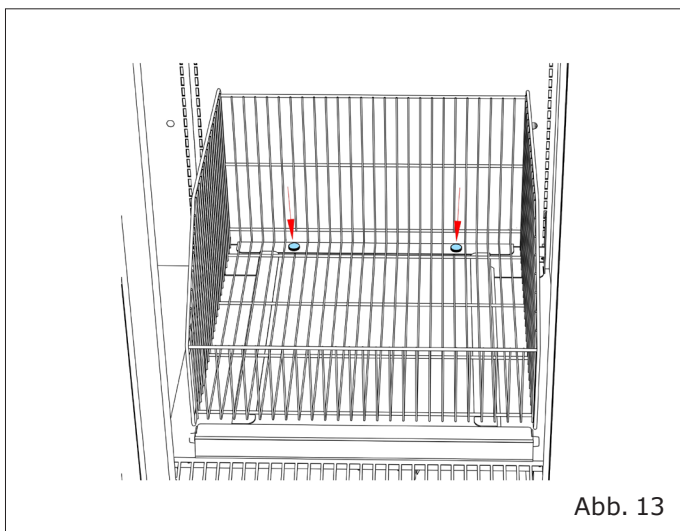
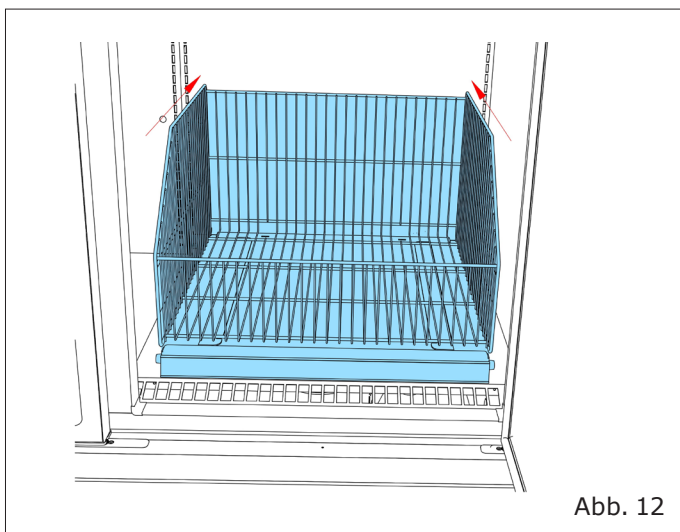

Vergewissern Sie sich sorgfältig, dass der Korb keine Rahmen oder Dichtungen der Vitrine oder der Tür berührt.

3.4 Reinigung der Auslagefläche



Die Reinigung der Auslagefläche darf nur durch geschultes Personal erfolgen.

- Legen Sie die Waren in eine Tiefkühlschränke oder gekühlte Tiefkühlräume.
- Vermeiden Sie eine Unterbrechung der Kühlkette.
- Trennen Sie das Gerät vom Stromnetz und stellen Sie sicher, dass der Strom keinesfalls durch unbefugte Personen wieder eingeschaltet wird.
- Entfernen Sie den Auszugskorb wie im Kapitel beschrieben "Herausnehmen des Korbes".



Abb. 15

- Reinigen Sie die Auslagefläche mit einem feuchten Tuch

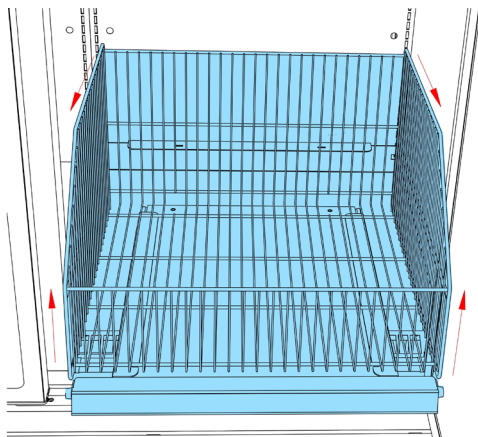

Abb. 16

- Ziehen Sie es aus.

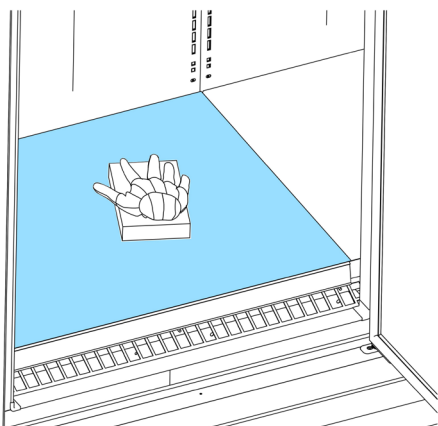

Abb. 17

- Entfernen Sie die Lufterinlass- und das Lüftungsgitter und reinigen Sie es mit einem feuchten Tuch.



Abb. 18

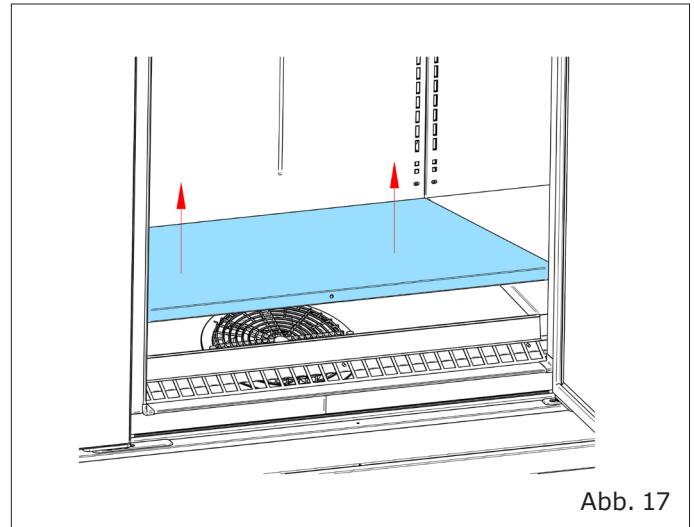

Abb. 19

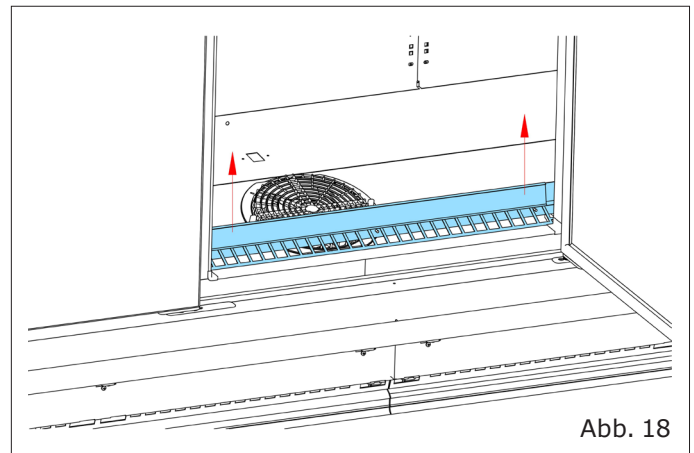

ACHTEN SIE AUF DIE ROTIERENDEN VERDAMPFERLÜFTER! BERÜHREN SIE DIE LÜFTER KEINESFALLS MIT DEN FINGERN, EINEM LAPPEN ODER EINEM ANDEREN HILFSMITTEL!

Modello - Modèle - Model Modell - Modelo - Modelo	GRANBERING INTEGRAL ULTRA	COSTAN eptarefrigeration
Fabbricante - Constructeur - Manufacturer Hersteller - Fabricante - Fabricante	Epta Spa - Via Mecenate, 86 - 20138 Milano (MI) ITALIA Tel. 02/55403211 Telefax 02/55401023	10/11

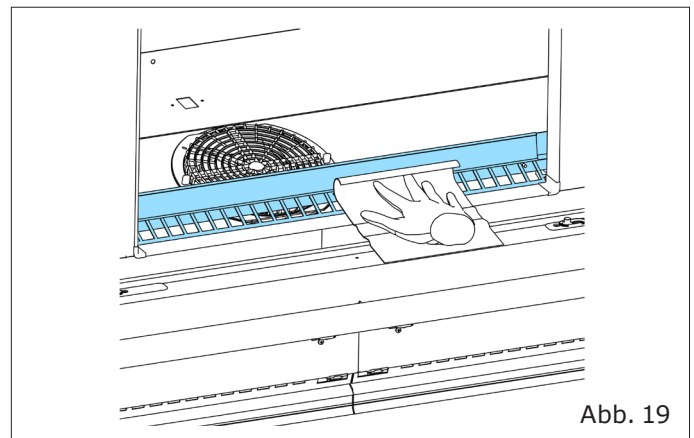
Cleaning instruction

IT
FR
EN
DE
ES
PT

- Geben Sie für die Reinigung der Auslagefläche etwas Seife oder Reinigungsmittel in lauwarmes Wasser. Stellen Sie sicher, dass der Abfluss frei ist.
- Setzen Sie die Lüftungsgitter wieder ein



Abb. 20

- Setzen Sie die Auslagefläche wieder ein.

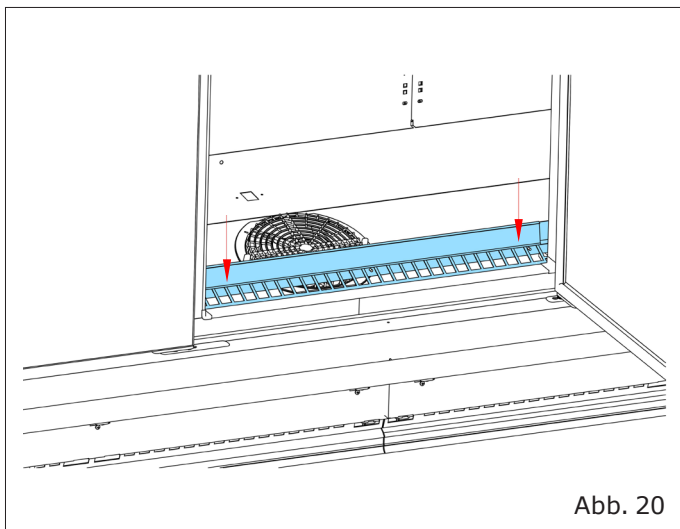

Abb. 21

- Setzen Sie den Korb wieder ein, wie in Kapitel "Herausnehmen des Korbes".

3.5 Reinigung des Kondensators

- Entfernen Sie die Kondensatorabdeckungen.

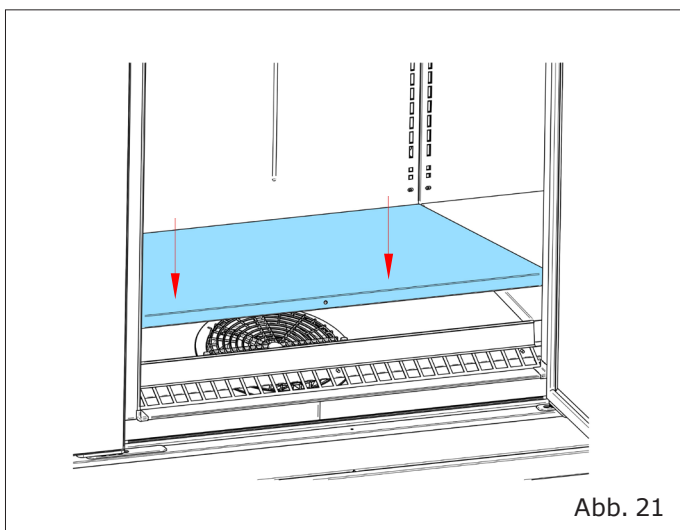

Abb. 22

- Reinigen Sie den Kondensator mit einem Industriestaubsauger oder einem Handfeger.

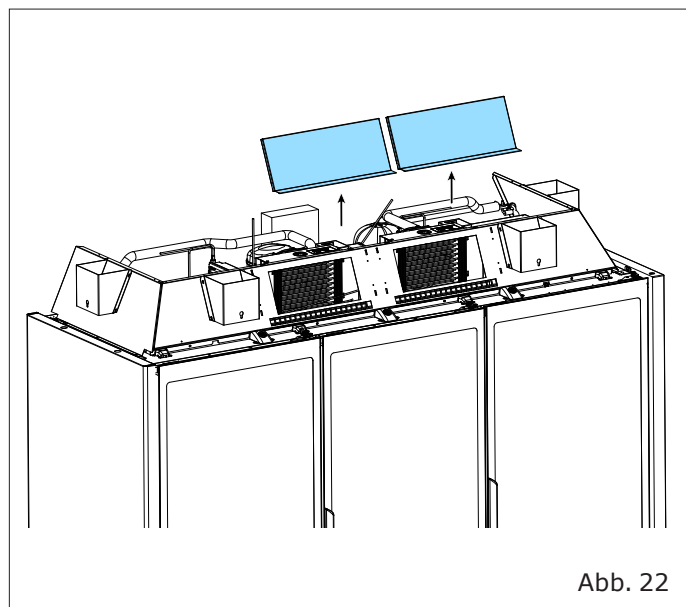

Abb. 23

Modello - Modèle - Model Modell - Modelo - Modelo	GRANBERING INTEGRAL ULTRA	COSTAN eptarefrigeration
Fabbricante - Constructeur - Manufacturer Hersteller - Fabricante - Fabricante	Epta Spa - Via Mecenate, 86 - 20138 Milano (MI) ITALIA Tel. 02/55403211 Telefax 02/55401023	11/11

3.6 Reinigung der Wasserauffangschale

- Entfernen Sie die vordere Abdeckung, indem Sie sie abhebeln.
- Ziehen Sie das Netzkabel ab.

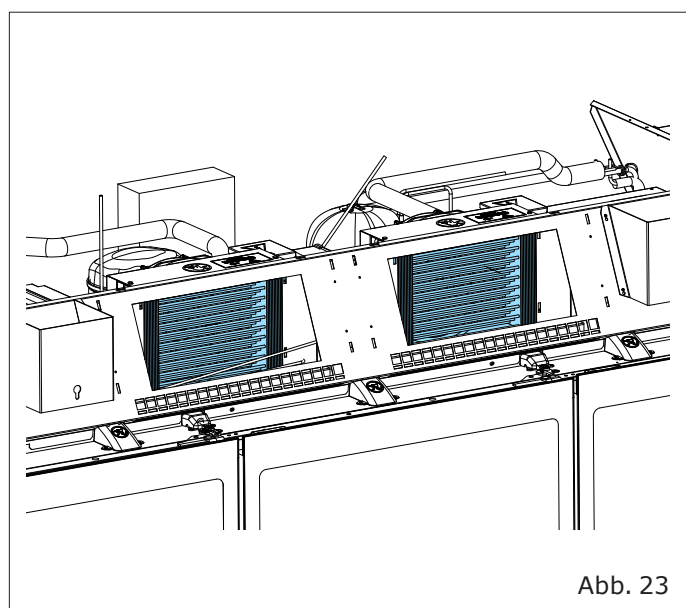

Abb. 24

- Ziehen Sie die Wasserschale heraus.

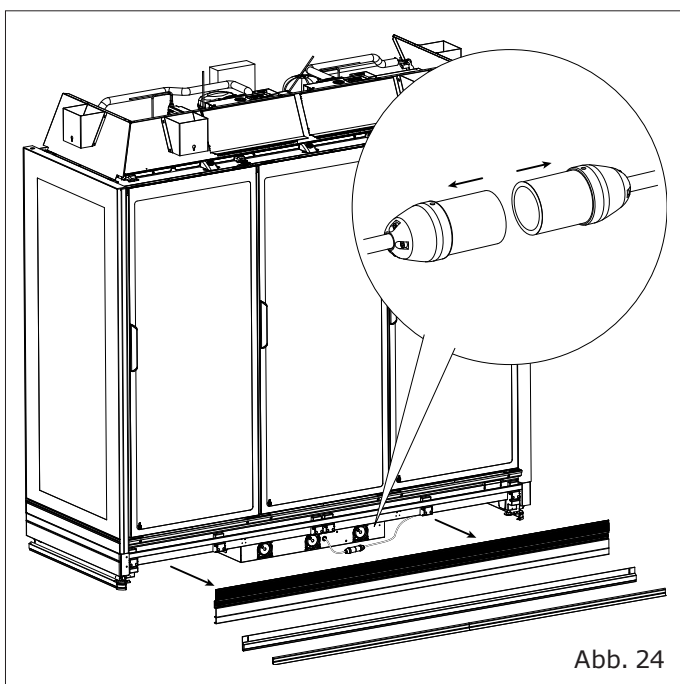

Abb. 25

- Lösen Sie die Schrauben und entfernen Sie die obere Abdeckung.
- Reinigen Sie die Wasserschale.

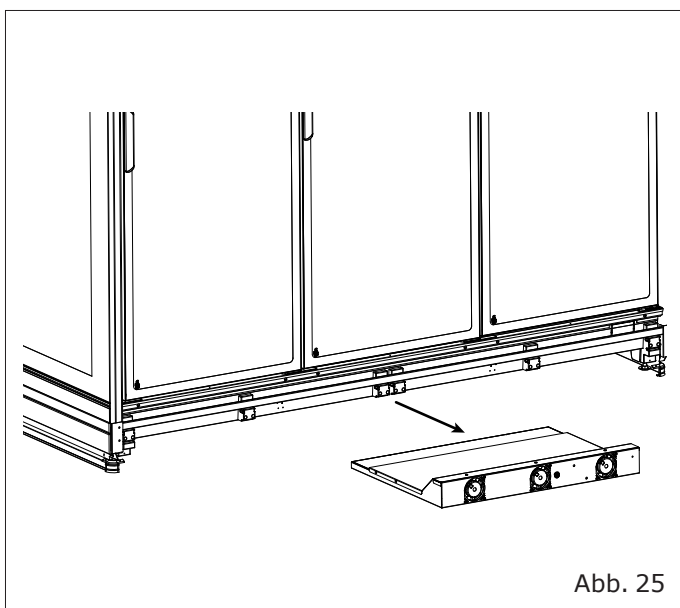

Abb. 26

3.7 Neustart des Kühlmöbels

- Nach erfolgter Reinigung stellen Sie sicher, dass das Innere des Kühlmöbels vollständig trocken ist. Erst dann schließen Sie es wieder an die Stromversorgung an und nehmen es in Betrieb.
- Der Kühlkreislauf startet. Warten Sie, bis die angezeigte Temperatur bei -18°C liegt, bevor Sie das Kühlmöbel befüllen.

Modello - Modèle - Model Modell - Modelo - Modelo	GRANBERING INTEGRAL ULTRA	COSTAN eptarefrigeration
Fabbricante - Constructeur - Manufacturer Hersteller - Fabricante - Fabricante	Epta Spa - Via Mecenate, 86 - 20138 Milano (MI) ITALIA Tel. 02/55403211 Telefax 02/55401023	2/11

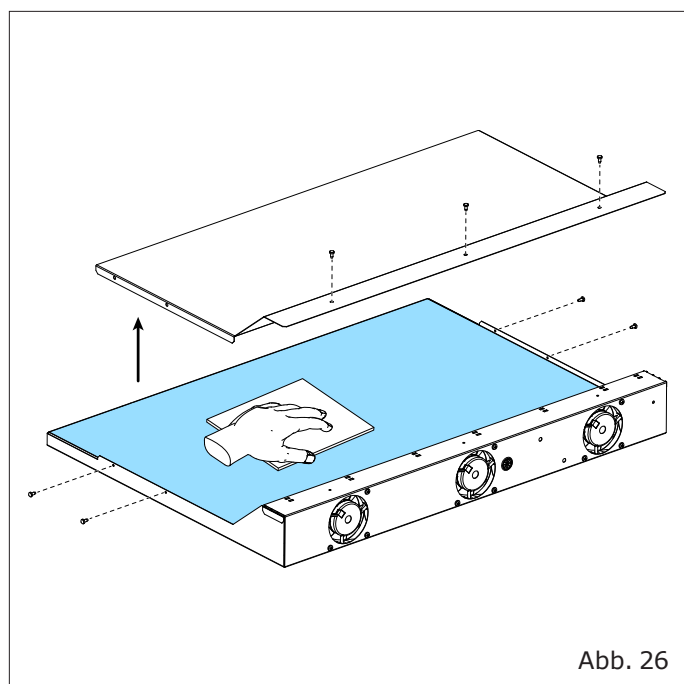
Cleaning instruction

CONTENT

IT

FR

EN

DE

ES

PT

1. Introduction	3
1.1 Scope	3
1.2 General safety information	3
1.3 Reasons for cleaning	3
2. Cleaning agents	4
3. Cleaning the appliance	5
3.1 Cleaning of the refrigerated display cabinet exterior	5
3.2 Cleaning of the refrigerated display cabinet interior	5
3.3 Removing of the basket	6
3.4 Cleaning of the base deck	9
3.5 Cleaning of the condenser	10
3.6 Water tray cleaning	11
3.7 Cabinet restart	11

SYMBOLS USED



Prohibition symbol: it prohibits the carrying out of specific operations.



Attention symbol: accident prevention rules for the operator.



Warning symbol: there is the possibility of damaging the cabinet and/or its components.



Note symbol: it provides useful information.

Personal protection equipment

	Safety shoes
	Protective gloves
	Safety glasses
	Safety helmet
	Safety vests

Modello - Modèle - Model Modell - Modelo - Modelo	GRANBERING INTEGRAL ULTRA	COSTAN <small>eptarefrigeration</small>
Fabbricante - Constructeur - Manufacturer Hersteller - Fabricante - Fabricante	Epta Spa - Via Mecenate, 86 - 20138 Milano (MI) ITALIA Tel. 02/55403211 Telefax 02/55401023	3/11

1. INTRODUCTION

1.1 Scope

The document "Cleaning Instructions" indicates how to clean the vertical frozen cabinet.

Instructions for use are also available on:
www.eptarefrigeration.com.

1.2 General safety information



Do never interrupt the cooling chain of displayed goods.



Before starting any maintenance or cleaning, disconnect the equipment from the electrical power supply and secure against re-connecting by unauthorized persons.



Ensure that the working area is sufficiently illuminated during maintenance and cleaning activities and use an additional lighting source if necessary.



Doors and glass walls are provided with an antifog liner film inside. Do not use any detergent containing abrasive, strongly acidic or caustic substances.



Beware of touching any rotation part of the cabinet (fans) with fingers, towels or other tools.



Do not remove any protective guards and covers.

1.3 Reasons for cleaning

In order to present goods attractively and hygienically, it is important to clean the freezer cabinet regularly. Regular cleaning also prevents mould and harmful bacteria from settling in the furniture, as damp dust provides an ideal breeding ground.

Regular cleaning is also essential for the technical function. This is the only way to ensure that an optimal heat exchange takes place and that air can flow easily in the cabinet.

IT

FR

EN

DE

ES

PT

Modello - Modèle - Model Modell - Modelo - Modelo	GRANBERING INTEGRAL ULTRA	COSTAN  <small>eptarefrigeration</small>
Fabbricante - Constructeur - Manufacturer Hersteller - Fabricante - Fabricante	Epta Spa - Via Mecenate, 86 - 20138 Milano (MI) ITALIA Tel. 02/55403211 Telefax 02/55401023	4/11

Cleaning instruction

IT 2. CLEANING AGENTS

FR

Work clothes

- Protective gloves
- Protective clothing
- Safety glasses

EN

DE

ES

Cleaning agent for surfaces other than glass

PT

- Water
- Mild detergent
- Non-scratching sponges, rags and soft cloths

Cleaning agent for glass surfaces

- Water
- Mild detergent
- Standard glass cleaner
- Oil stain removers
- Non-scratching sponges, rags and paper towels

The following must not be used

- Strong corrosive cleaning agents
- Acidic or caustic cleaning agents
- Inflammable agents
- Acetone
- Solvent containing cleaning agents
- Abrasive cleaners
- Jet-wash cleaner or other strong water jet to clean

Modello - Modèle - Model Modell - Modelo - Modelo	GRANBERING INTEGRAL ULTRA	COSTAN eptarefrigeration
Fabbricante - Constructeur - Manufacturer Hersteller - Fabricante - Fabricante	Epta Spa - Via Mecenate, 86 - 20138 Milano (MI) ITALIA Tel. 02/55403211 Telefax 02/55401023	5/11

3. CLEANING THE APPLIANCE

3.1 Cleaning of the refrigerated display cabinet exterior

- Clean the outer surfaces of the display case with mild soap or detergent in lukewarm water only.
- Wipe carefully with non-scratching sponges, rags and soft cloths.

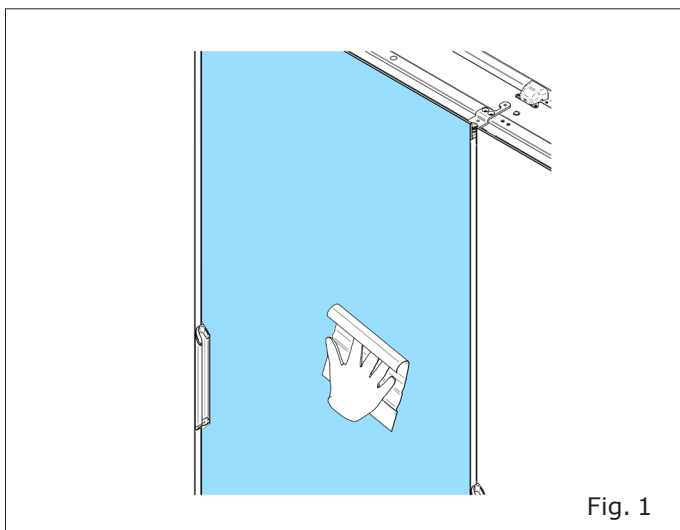

Cleaning of the glass doors and glass walls inside:

- Clean it by using standard glass cleaner with a non-abrasive sponge, a rag or a paper towel.

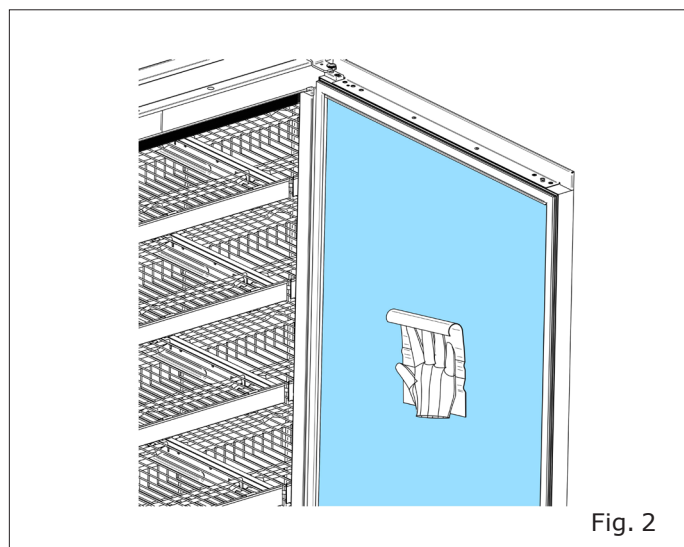

 Greasy residue must be removed using oil stain remover.

3.2 Cleaning of the refrigerated display cabinet interior

- Remove the displayed goods into chest freezer or freezer rooms.
- Avoid interrupting the cooling chain.
- Disconnect the cabinet from the electrical power supply and secure against re-connecting by unauthorized persons.

Cleaning of the shelves:

- The surfaces can be cleaned with mild soap or detergent in lukewarm water.

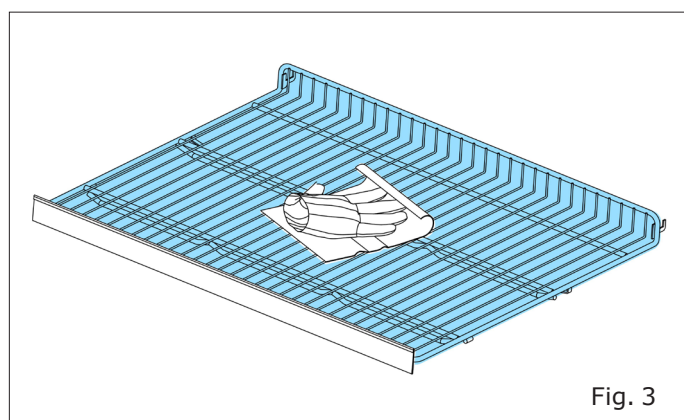

Modello - Modèle - Model Modell - Modelo - Modelo	GRANBERING INTEGRAL ULTRA	
Fabbricante - Constructeur - Manufacturer Hersteller - Fabricante - Fabricante	Epta Spa - Via Mecenate, 86 - 20138 Milano (MI) ITALIA Tel. 02/55403211 Telefax 02/55401023	6/11

Cleaning instruction

IT

FR

EN

DE

ES

PT

- For convenient cleaning you can detach the shelves and take them off the rack.

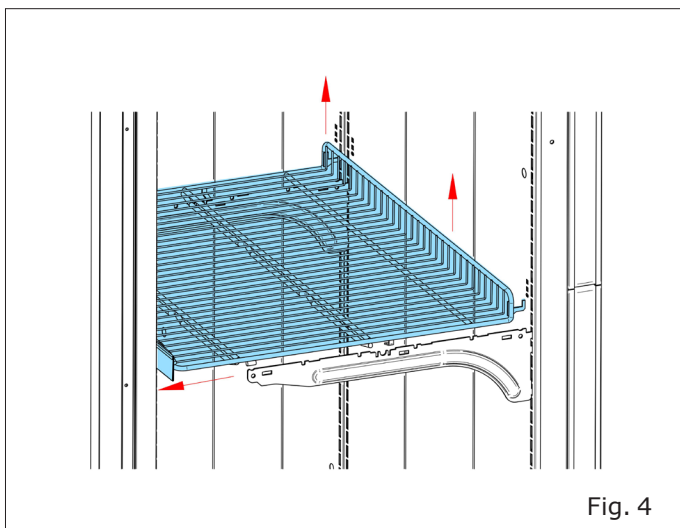

Fig. 4



Please rotate the shelf to extract it from the cabinet.

- Make sure that the brackets are in the correct position and that the brackets lock completely into the support when you reattach them.

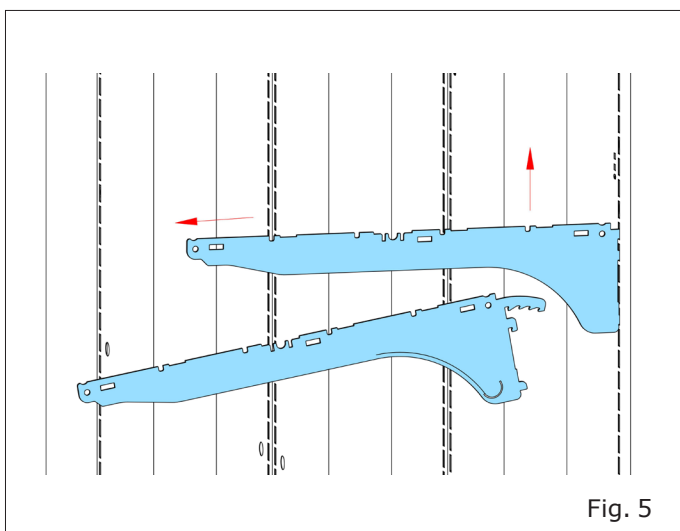

Fig. 5

Cleaning of the air return grid:

- Clean the air return grid with a vacuum cleaner and/or clean the grid with a moist rag.

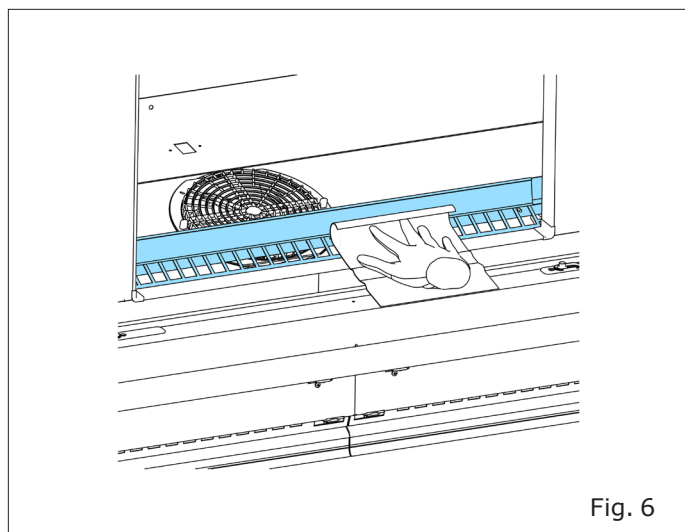

Fig. 6

3.3 Removing of the basket

- The freezer cabinet can be supplied with a pull-out basket.

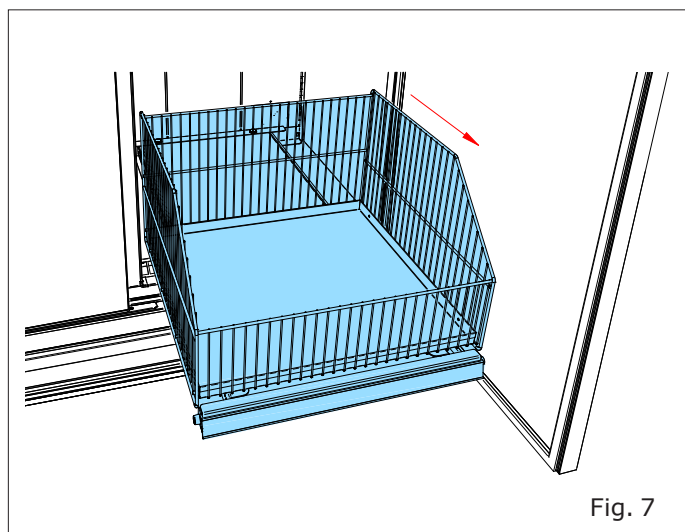
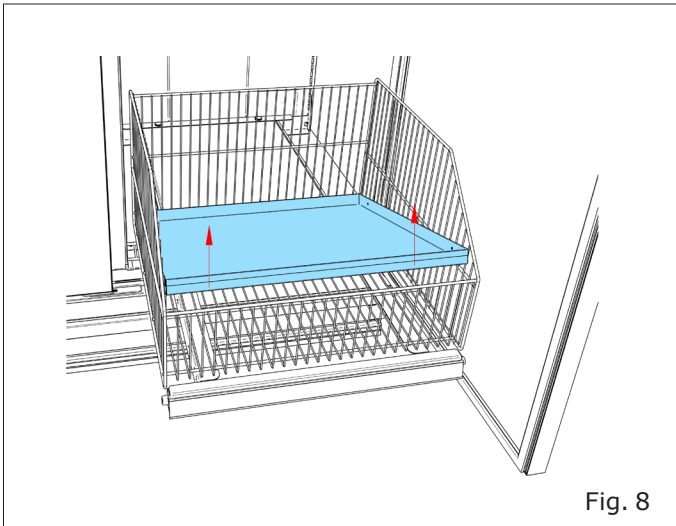
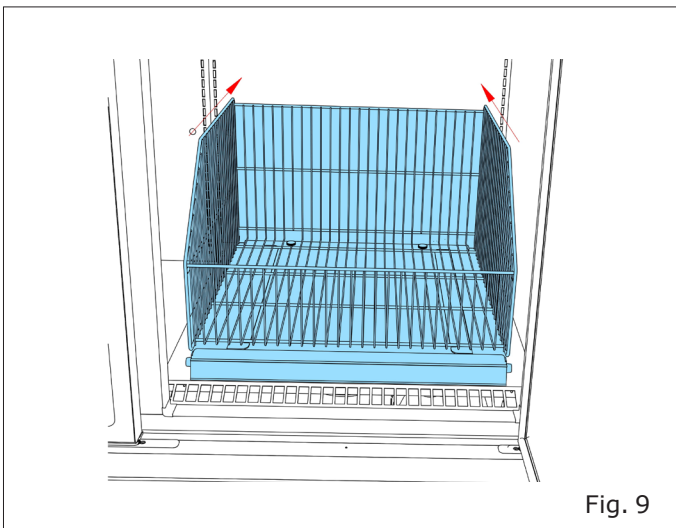

Fig. 7

- This can be removed for cleaning.
- To do this, pull out the basket from the cabinet and remove the two knurled nuts. The basket can then be removed.



Remove the panel inside.



Put the basket inside to remove the knurled nuts.

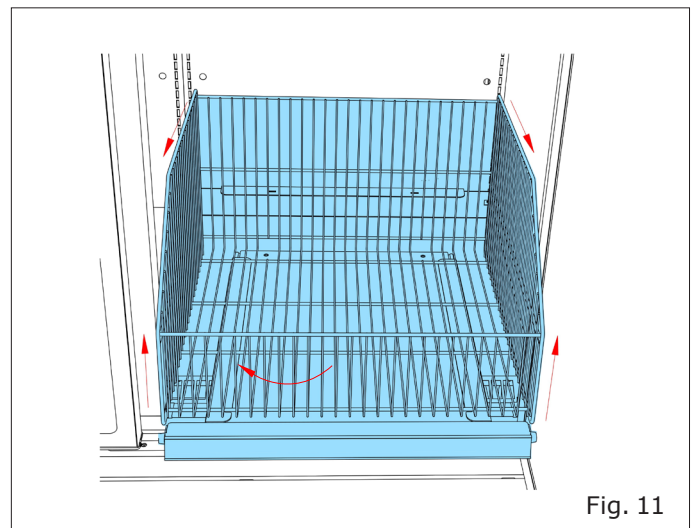
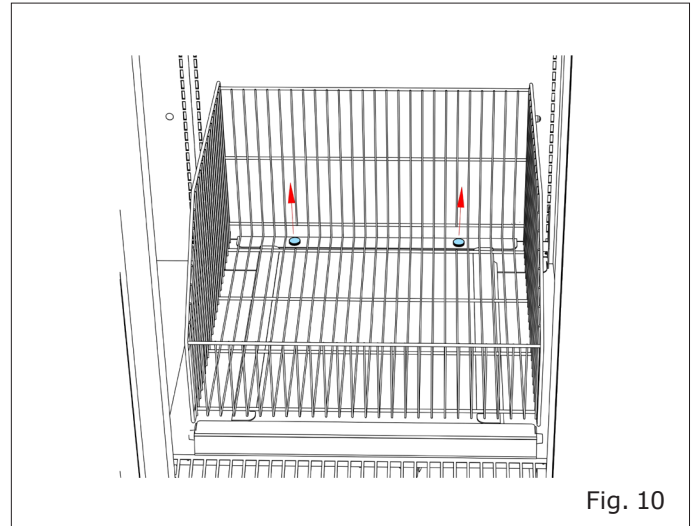

IT

FR

EN

DE

ES

PT

Cleaning instruction

IT

- Reinstall the basket in reverse order. Align the basket and fix it with the knurled nuts.

FR

- Store the knurled nuts carefully and replace them after cleaning to fix the basket.

EN

DE

ES

PT

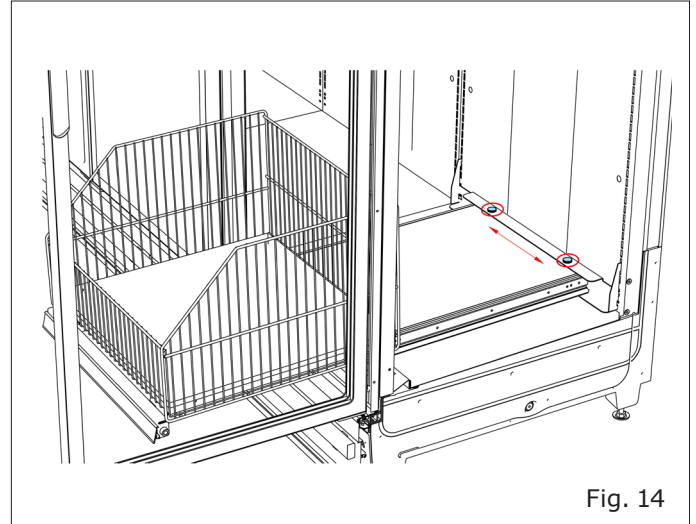
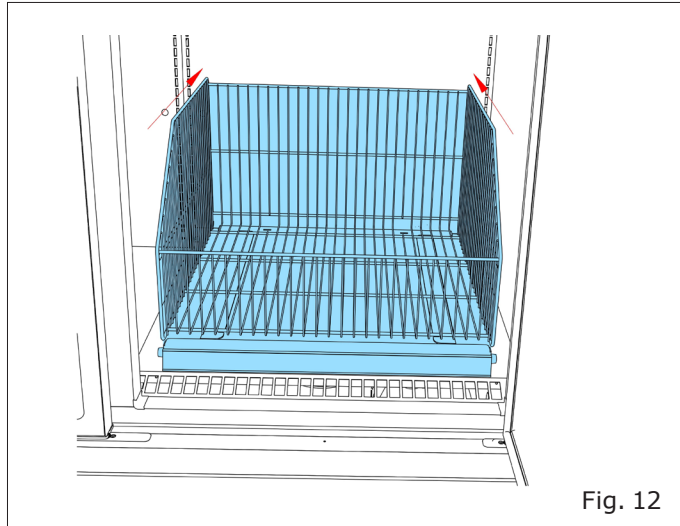

Check carefully that the basket will not touch any frame or seals of the display case or door.

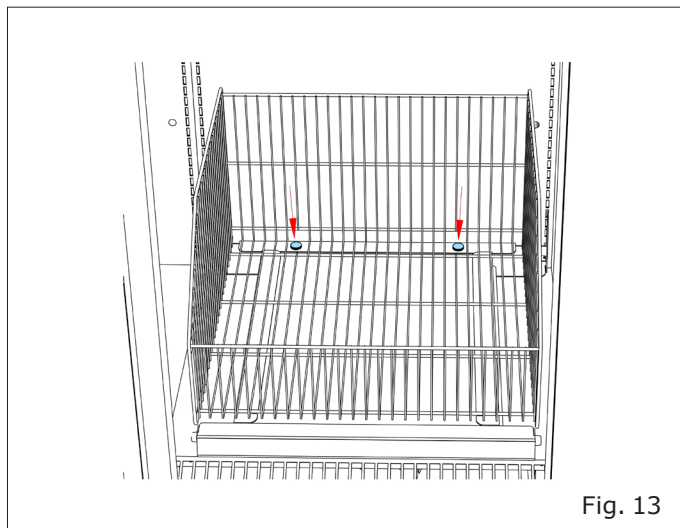

Modello - Modèle - Model Modell - Modelo - Modelo	GRANBERING INTEGRAL ULTRA	COSTAN eptarefrigeration
Fabbricante - Constructeur - Manufacturer Hersteller - Fabricante - Fabricante	Epta Spa - Via Mecenate, 86 - 20138 Milano (MI) ITALIA Tel. 02/55403211 Telefax 02/55401023	9/11

3.4 Cleaning of the base deck



Cleaning of the base deck must be done by trained personnel only.

- Remove the displayed goods into chest freezer or freezer rooms.
- Avoid interrupting the cooling chain.
- Disconnect the cabinet from the electrical power supply and secure against re-connecting by unauthorized persons.
- Remove the pull-out basket as described in chapter "Removing of the basket".

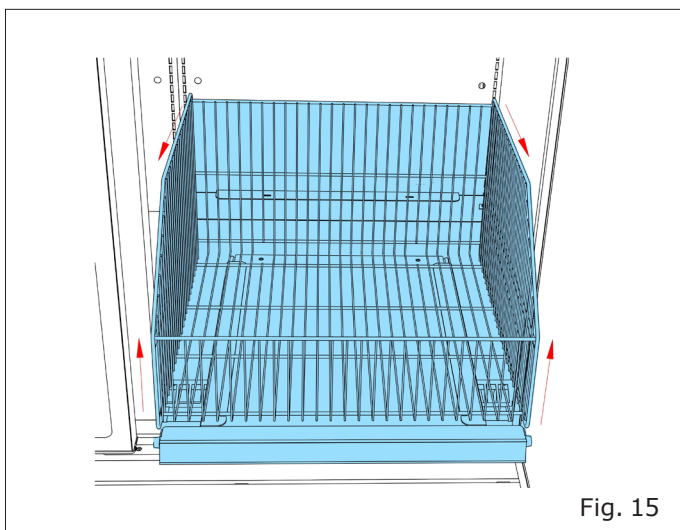

Fig. 15

- Clean the base deck by using a moist rag.

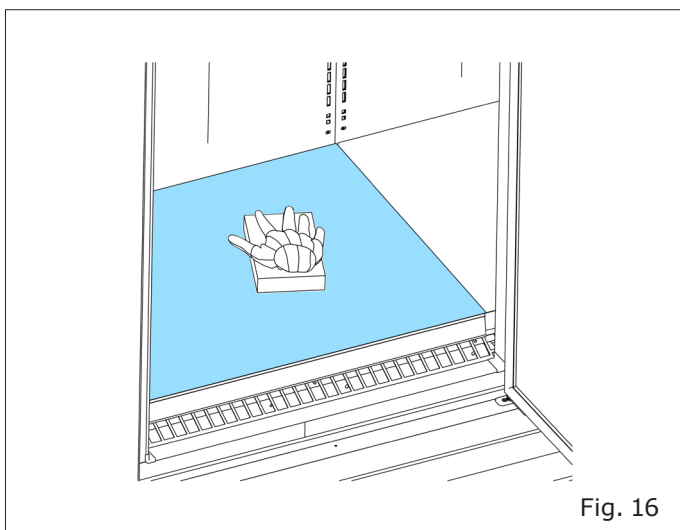

Fig. 16

- Take it off.

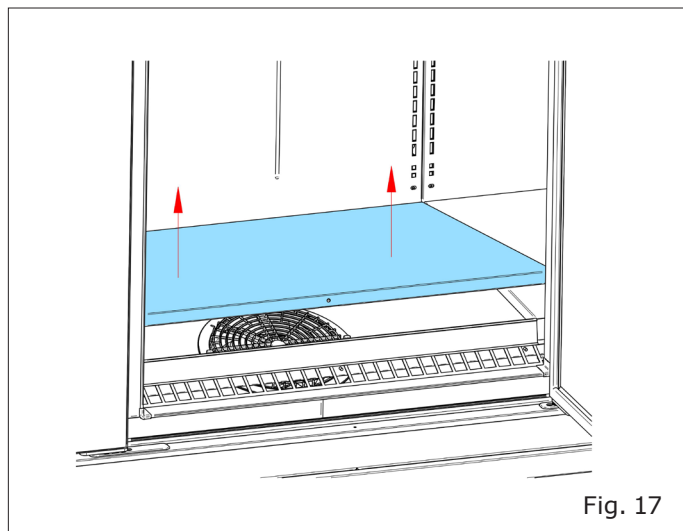

Fig. 17

- Remove the air return grid and air discharge grid and clean them by using a moist rag.

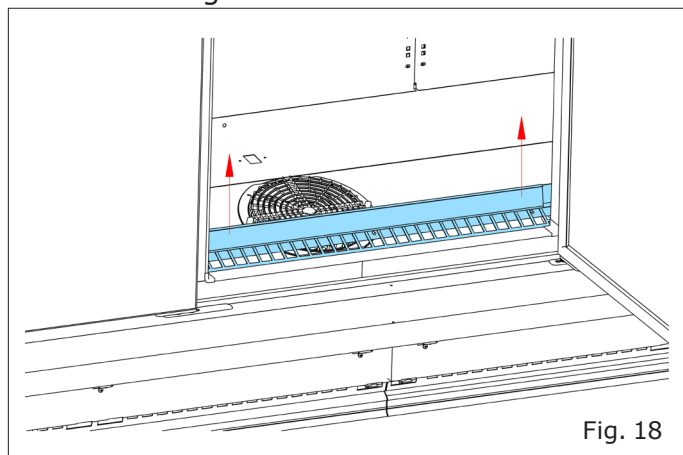

Fig. 18

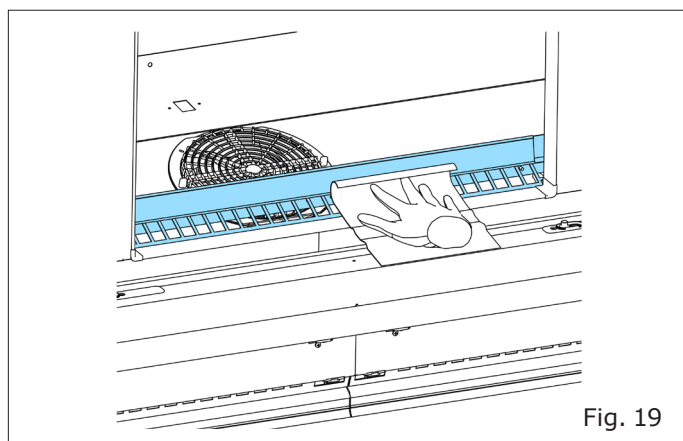

Fig. 19



Be aware of rotating evaporator fans!
Do not touch them with finger, rags or other tools.

Modello - Modèle - Model Modell - Modelo - Modelo	GRANBERING INTEGRAL ULTRA	COSTAN eptarefrigeration
Fabbricante - Constructeur - Manufacturer Hersteller - Fabricante - Fabricante	Epta Spa - Via Mecenate, 86 - 20138 Milano (MI) ITALIA Tel. 02/55403211 Telefax 02/55401023	10/11

Cleaning instruction

IT

FR

EN

DE

ES

PT

- Clean the base tray with mild soap or detergent in lukewarm water. Check that the drain is unclogged.
- Reinstall the air return grid.

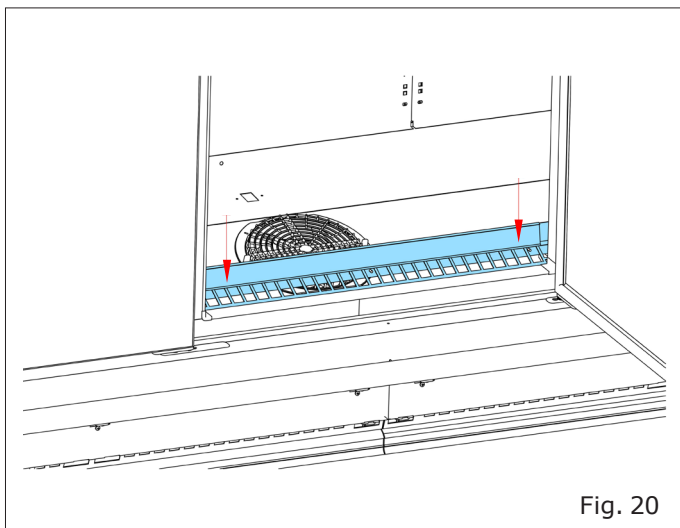

Fig. 20

- Reinstall the base deck.

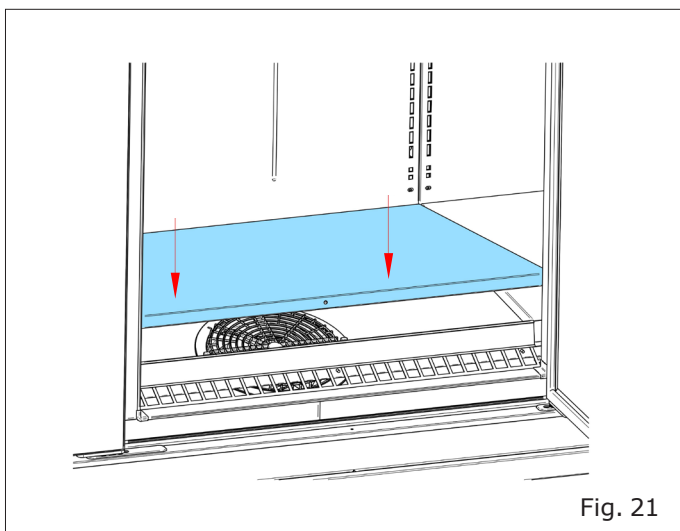

Fig. 21

- Reinstall the basket as described in chapter "Removing of the basket".

3.5 Cleaning of the condenser

- Remove the condenser covers.

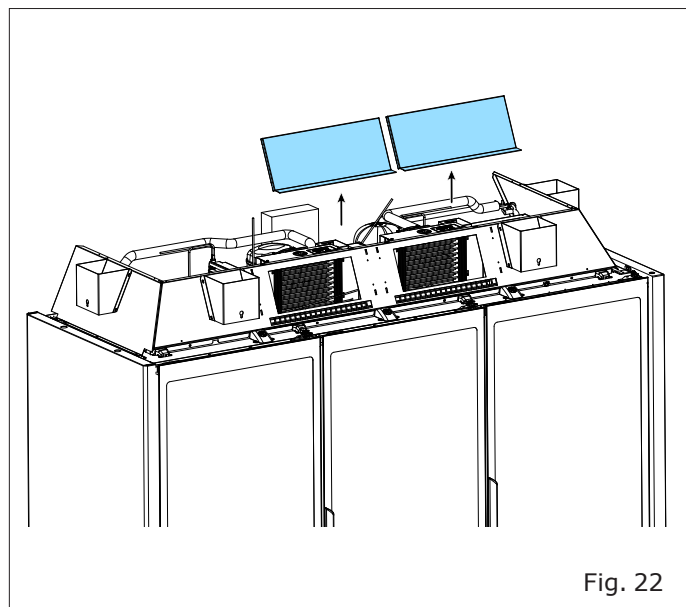

Fig. 22

- Clean the condenser with an industrial vacuum cleaner or a hand brush.

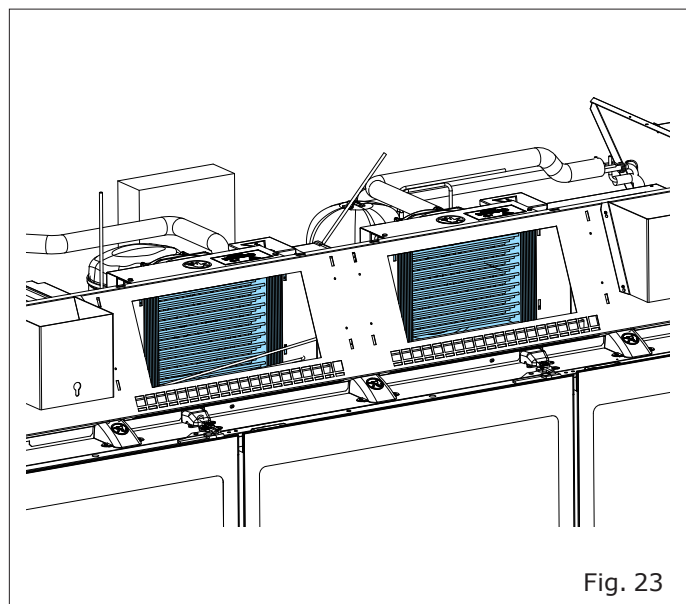
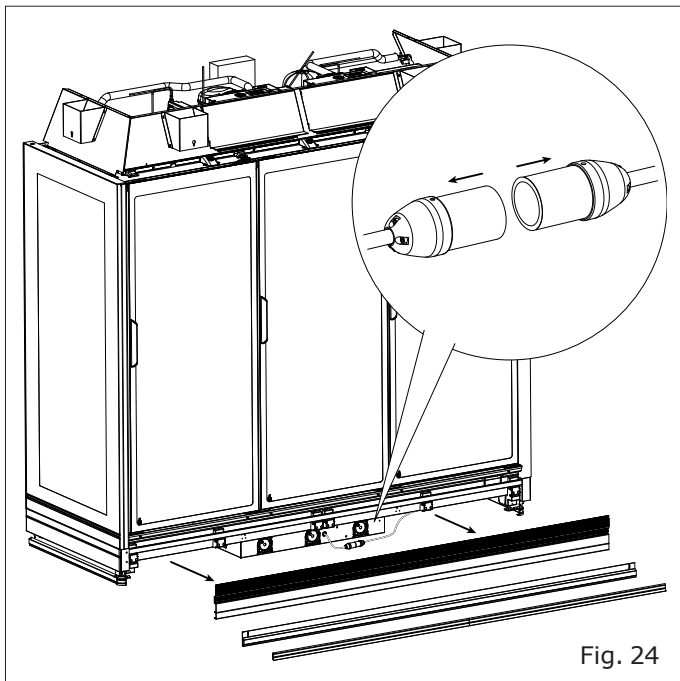

Fig. 23

Modello - Modèle - Model Modell - Modelo - Modelo	GRANBERING INTEGRAL ULTRA	COSTAN eptarefrigeration
Fabbricante - Constructeur - Manufacturer Hersteller - Fabricante - Fabricante	Epta Spa - Via Mecenate, 86 - 20138 Milano (MI) ITALIA Tel. 02/55403211 Telefax 02/55401023	11/11

3.6 Water tray cleaning

- Remove the front cover by prying it off.
- Unplug the power cable.



- Pull out the water tray.

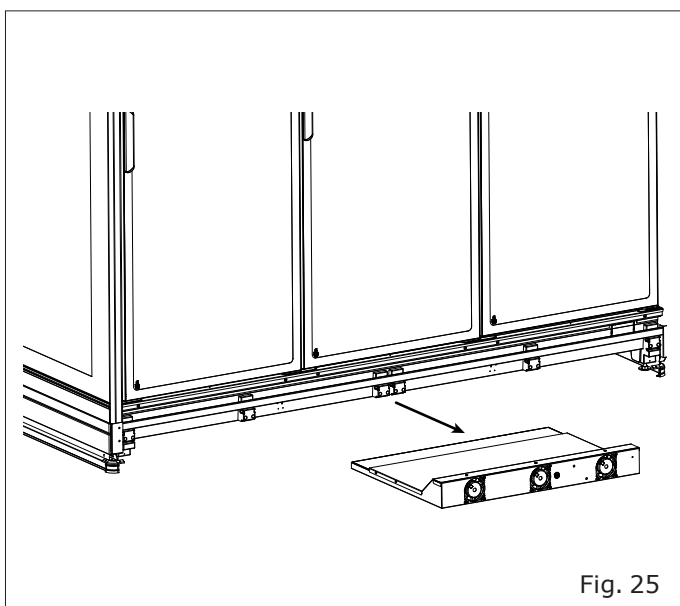

- Unscrew the screws and remove the top panel.
- Clean the water tray.

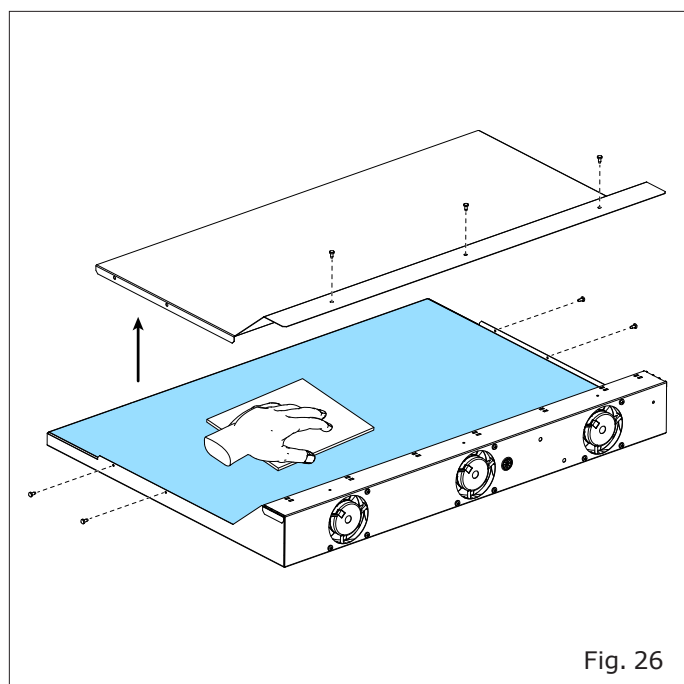

3.7 Cabinet restart

- After completing the cleaning and attentively checking that the inside of the cabinet is completely dry, put the appliance back into operation by reconnecting power to the cabinet.
- The cabinet will then start its cooling cycle. Allow cabinets to reach a displayed temperature of -18°C before reloading the removed goods.

Modello - Modèle - Model Modell - Modelo - Modelo	GRANBERING INTEGRAL ULTRA	COSTAN <small>eptarefrigeration</small>
Fabbricante - Constructeur - Manufacturer Hersteller - Fabricante - Fabricante	Epta Spa - Via Mecenate, 86 - 20138 Milano (MI) ITALIA Tel. 02/55403211 Telefax 02/55401023	2/11

Cleaning instruction

ÍNDICE

IT

FR

EN

DE

ES

PT

1. Introducción	3
1.1 Alcance	3
1.2 Información general de seguridad	3
1.3 Razones para limpiar	3
2. Agentes de limpieza	4
3. Limpieza del aparato	5
3.1 Limpieza del exterior de la vitrina refrigerada	5
3.2 Limpieza del interior de la vitrina refrigerada	5
3.3 Retiro de la canasta	6
3.4 Limpieza de la plataforma base	9
3.5 limpieza del condensador	10
3.6 limpieza de la bandeja de evaporación de agua	11
3.7 Reinicio del gabinete	11

SÍMBOLOS UTILIZADOS



Símbolo de prohibición: se prohíbe realizar determinadas operaciones.



Símbolo de atención: normas de prevención de accidentes para el operador.



Símbolo de advertencia: posibilidad de dañar el mueble y/o sus componentes.



Símbolo de nota: proporciona información útil.

Equipo de protección personal

	Zapatos de seguridad
	Guantes protectores
	Lentes de seguridad
	Casco de seguridad
	Chalecos de seguridad

Modello - Modèle - Model Modell - Modelo - Modelo	GRANBERING INTEGRAL ULTRA	COSTAN eptarefrigeration
Fabbricante - Constructeur - Manufacturer Hersteller - Fabricante - Fabricante	Epta Spa - Via Mecenate, 86 - 20138 Milano (MI) ITALIA Tel. 02/55403211 Telefax 02/55401023	3/11

1. INTRODUCCIÓN

1.1 Alcance

El documento "Cleaning Instructions" indica cómo limpiar un expositor de productos refrigerados para alimentos congelados.

Las instrucciones de uso también están disponibles en:
www.eptarefrigeration.com.

1.2 Información general de seguridad



No interrumpa nunca la cadena de refrigeración de los productos expuestos.



Antes de iniciar cualquier mantenimiento o limpieza, desconecte el equipo de la fuente de alimentación eléctrica y asegúrelo contra la reconexión por parte de personas no autorizadas.



Asegúrese de que el área de trabajo esté suficientemente iluminada durante las actividades de mantenimiento y limpieza y utilice una fuente de iluminación adicional si es necesario.



Las puertas y las paredes de vidrio están provistas de una película de revestimiento antivaho en el interior. No utilice ningún detergente que contenga sustancias abrasivas, fuertemente ácidas o cáusticas.



Tenga cuidado de tocar cualquier parte giratoria del gabinete (ventiladores) con los dedos, toallas u otras herramientas.



No retire ninguna protección ni cubierta.

1.3 Razones para limpiar

Para presentar los productos de forma atractiva e higiénica, es importante limpiar el armario del congelador con regularidad. La limpieza regular también evita que el moho y las bacterias dañinas se asienten en los muebles, ya que el polvo húmedo proporciona un caldo de cultivo ideal.

La limpieza regular también es esencial para la función técnica. Esta es la única forma de garantizar que se produzca un intercambio de calor óptimo y que el aire pueda fluir fácilmente en el armario.

IT

FR

EN

DE

ES

PT

Modello - Modèle - Model Modell - Modelo - Modelo	GRANBERING INTEGRAL ULTRA	COSTAN  <small>eptarefrigeration</small>
Fabbricante - Constructeur - Manufacturer Hersteller - Fabricante - Fabricante	Epta Spa - Via Mecenate, 86 - 20138 Milano (MI) ITALIA Tel. 02/55403211 Telefax 02/55401023	4/11

Cleaning instruction

IT 2. AGENTES DE LIMPIEZA

FR

Ropa de trabajo

- Guantes protectores
- Ropa protectora
- Lentes de seguridad

EN

DE

ES

Agente de limpieza para superficies que no sean de vidrio

PT

- Agua
- Detergente suave
- Esponjas, trapos y paños suaves que no rayen

Agente de limpieza para superficies de vidrio.

- Agua
- Detergente suave
- Limpiacristales estándar
- Quitamanchas de aceite
- Esponjas, trapos y toallas de papel que no rayan

No se debe utilizar lo siguiente

- Agentes de limpieza corrosivos fuertes
- Agentes de limpieza ácidos o cáusticos
- Agentes inflamables
- Acetona
- Agentes de limpieza que contienen disolventes
- Limpiadores abrasivos
- Limpiador a chorro u otro chorro de agua fuerte para limpiar

Modello - Modèle - Model Modell - Modelo - Modelo	GRANBERING INTEGRAL ULTRA	COSTAN eptarefrigeration
Fabbricante - Constructeur - Manufacturer Hersteller - Fabricante - Fabricante	Epta Spa - Via Mecenate, 86 - 20138 Milano (MI) ITALIA Tel. 02/55403211 Telefax 02/55401023	5/11

3. LIMPIEZA DEL APARATO

3.1 Limpieza del exterior de la vitrina refrigerada

- Limpie las superficies exteriores de la vitrina con jabón suave o detergente solo con agua tibia.
- Limpie cuidadosamente con esponjas que no rayen, trapos y paños suaves.

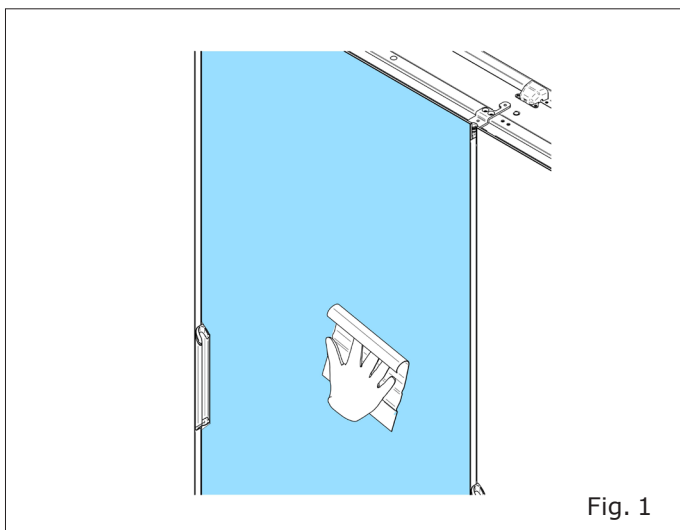

Limpieza de las puertas de cristal y paredes de cristal en el interior:

- Límpiolo con un limpiacristales estándar con una esponja no abrasiva, un trapo o una toalla de papel.

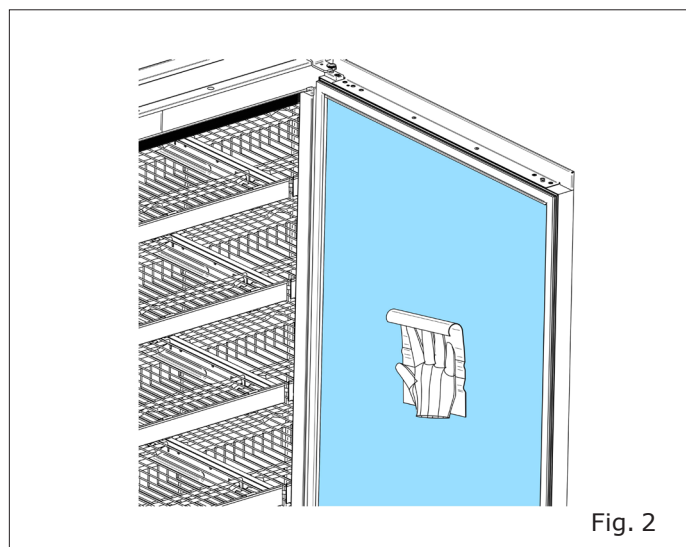

Los restos de grasa deben eliminarse con quitamanchas de aceite.

3.2 Limpieza del interior de la vitrina refrigerada

- Retire los productos expuestos en el arcón congelador o en las cámaras frigoríficas.
- Evite interrumpir la cadena de refrigeración.
- Desconecte el armario de la fuente de alimentación eléctrica y asegúrelo contra la reconexión por parte de personas no autorizadas.

Limpieza de los estantes:

- Las superficies se pueden limpiar con jabón suave o detergente en agua tibia.

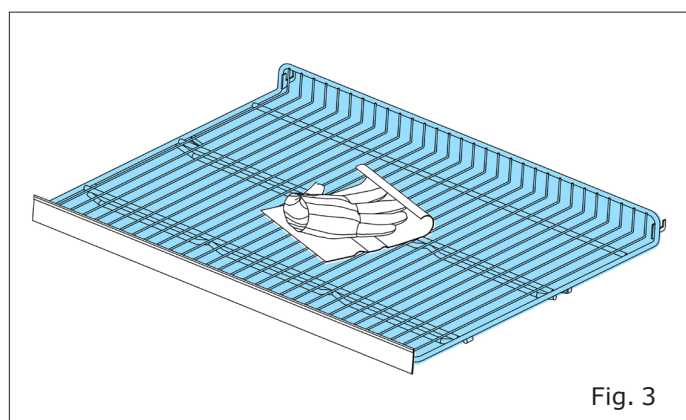

Modello - Modèle - Model Modell - Modelo - Modelo	GRANBERING INTEGRAL ULTRA	COSTAN eptarefrigeration
Fabbricante - Constructeur - Manufacturer Hersteller - Fabricante - Fabricante	Epta Spa - Via Mecenate, 86 - 20138 Milano (MI) ITALIA Tel. 02/55403211 Telefax 02/55401023	6/11

Cleaning instruction

IT
FR
EN
DE
ES
PT

- Para una limpieza conveniente, puede separar los estantes y sacarlos del estante.

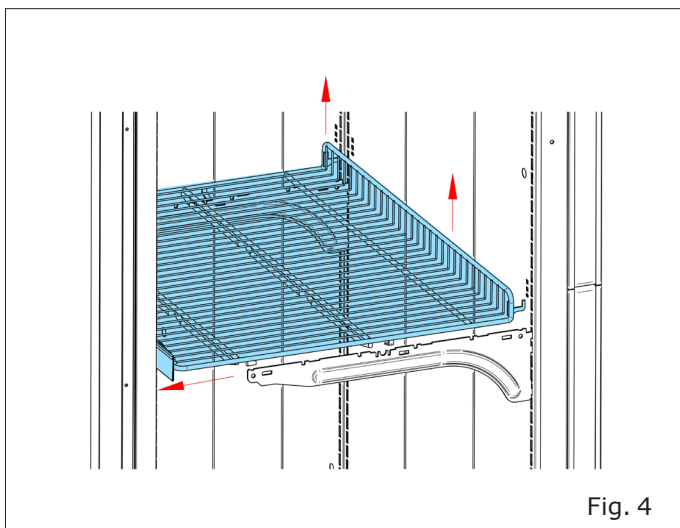

Fig. 4



Gire el estante para extraerlo del gabinete.

- Asegúrese de que los soportes estén en la posición correcta y que los soportes encajen completamente en el soporte cuando los vuelva a colocar.

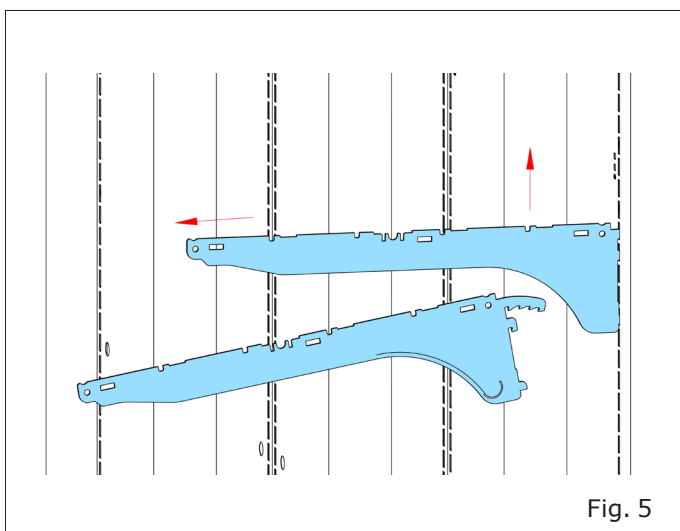

Fig. 5

Limpieza de la rejilla de retorno de aire:

- Limpie la rejilla de retorno de aire con una aspiradora y/o limpie la rejilla con un trapo húmedo.

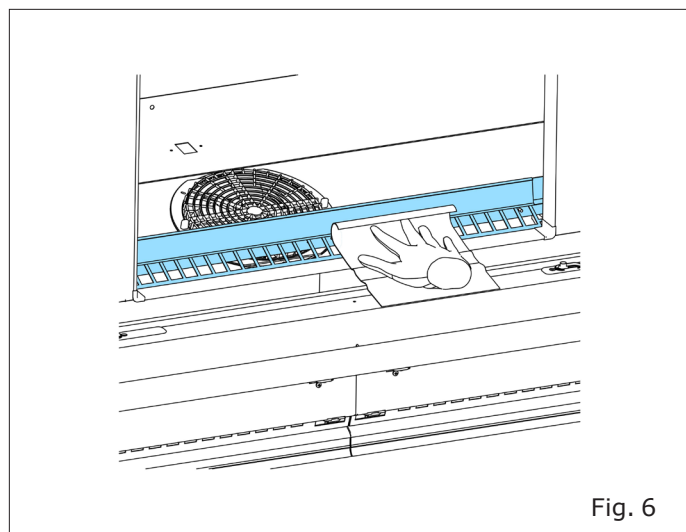

Fig. 6

3.3 Retiro de la canasta

- El armario congelador se puede suministrar con una cesta extraíble.

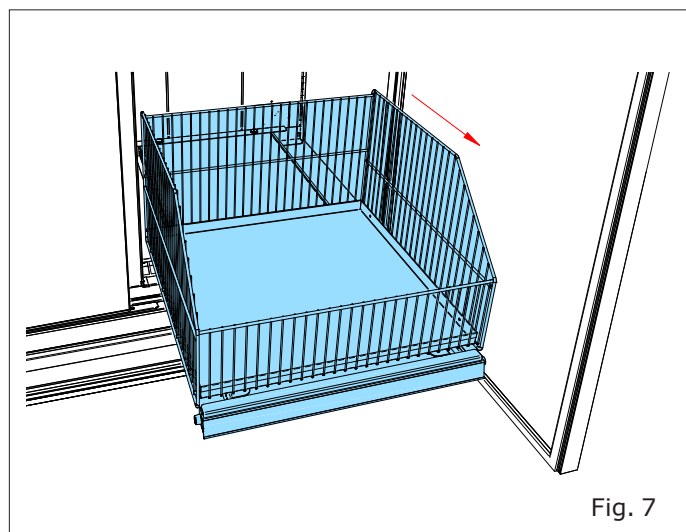
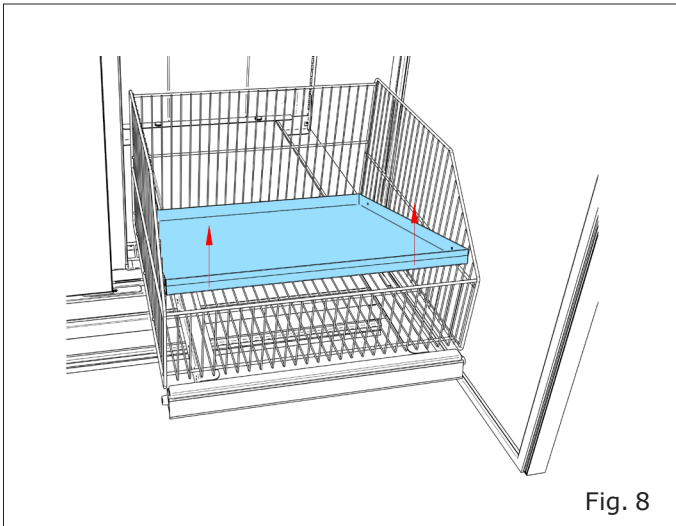
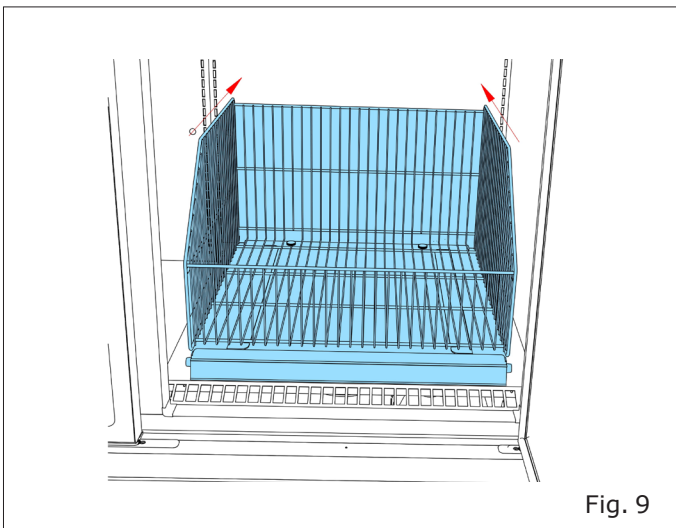

Fig. 7

- Esto se puede quitar para limpiarlo.
- Para ello, extraiga la cesta del armario y retire las dos tuercas moleteadas. A continuación, se puede retirar la cesta.



Retire el panel interior.



Coloque la cesta dentro para quitar las tuercas moleteadas.

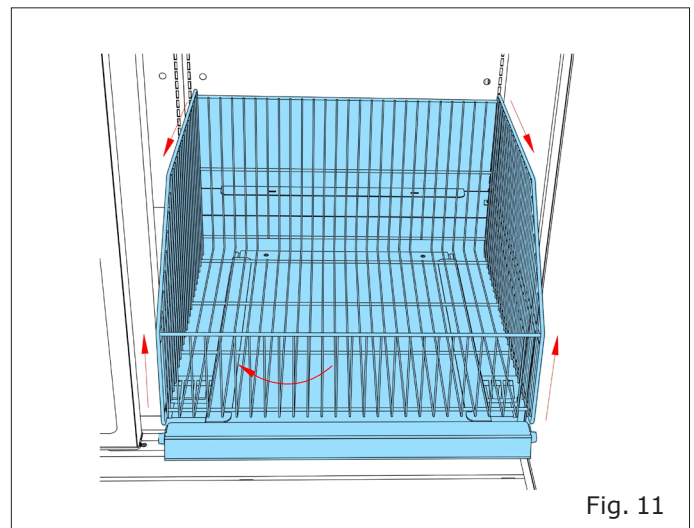
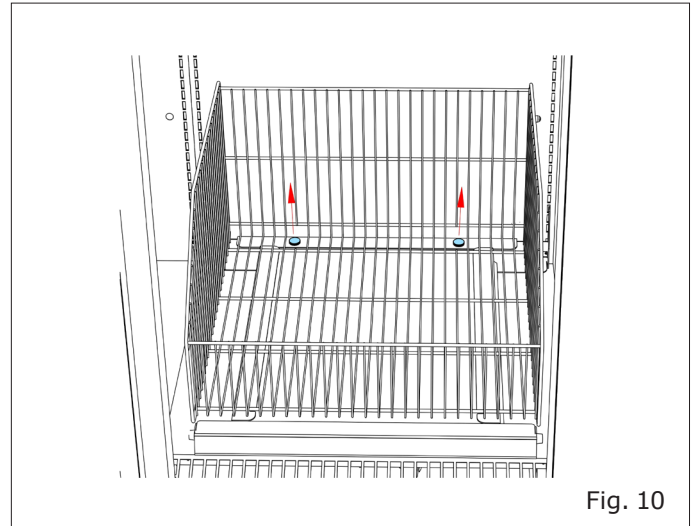

IT

FR

EN

DE

ES

PT

Modello - Modèle - Model Modell - Modelo - Modelo	GRANBERING INTEGRAL ULTRA	
Fabbricante - Constructeur - Manufacturer Hersteller - Fabricante - Fabricante	Epta Spa - Via Mecenate, 86 - 20138 Milano (MI) ITALIA Tel. 02/55403211 Telefax 02/55401023	8/11

Cleaning instruction

IT
FR
EN
DE
ES
PT

- Vuelva a instalar la cesta en orden inverso. Alinee la cesta y fíjela con las tuercas moleteadas.
- Guarde las tuercas moleteadas con cuidado y vuelva a colocarlas después de la limpieza para fijar la cesta.

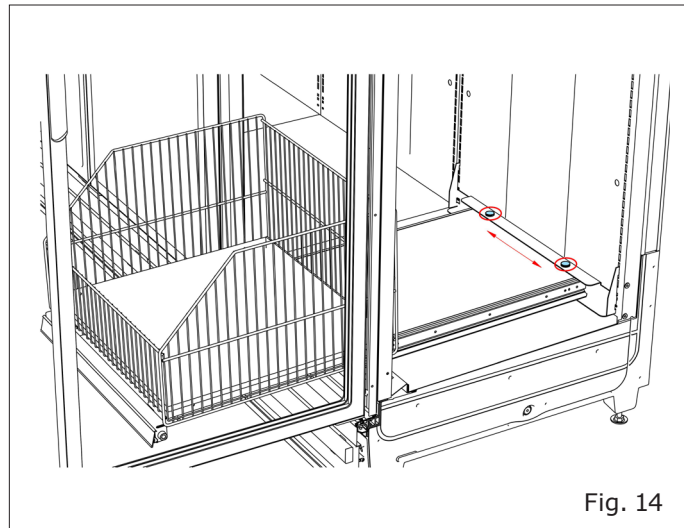
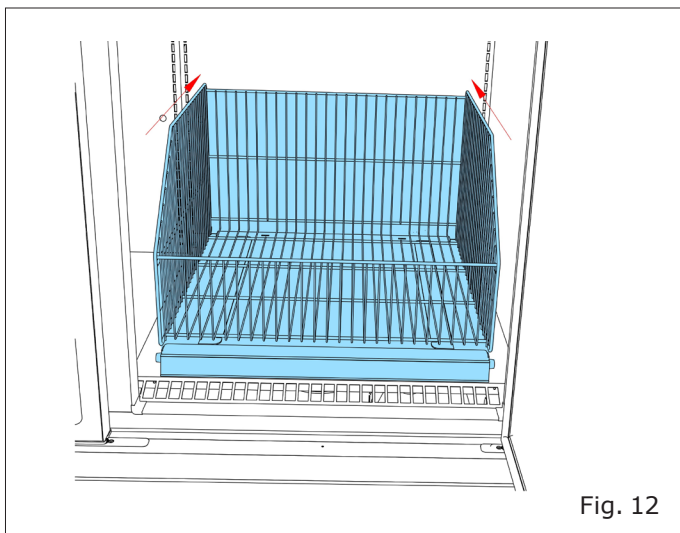

Verifique cuidadosamente que la canasta no toque ningún marco o sellos de la vitrina o puerta.

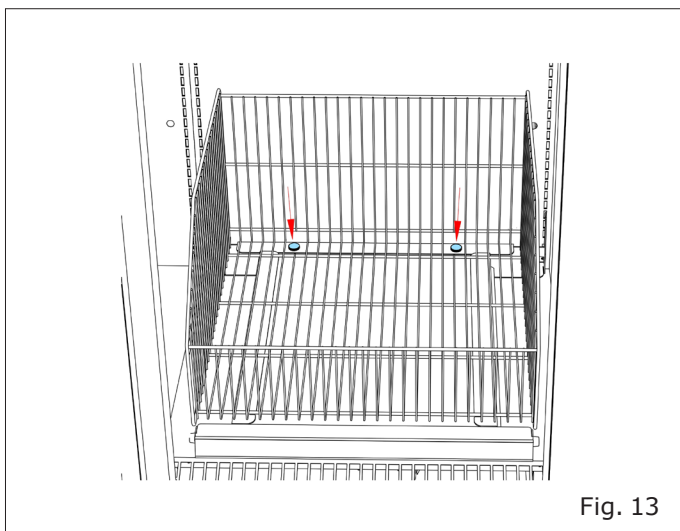

3.4 Limpieza de la plataforma base



La limpieza de la plataforma base debe ser realizada únicamente por personal capacitado.

- Retire los productos expuestos en el arcón congelador o en las cámaras frigoríficas.
- Evite interrumpir la cadena de refrigeración.
- Desconecte el armario de la fuente de alimentación eléctrica y asegúrelo contra la reconexión por parte de personas no autorizadas.
- Retire la cesta extraíble como se describe en el capítulo "Retiro de la canasta".

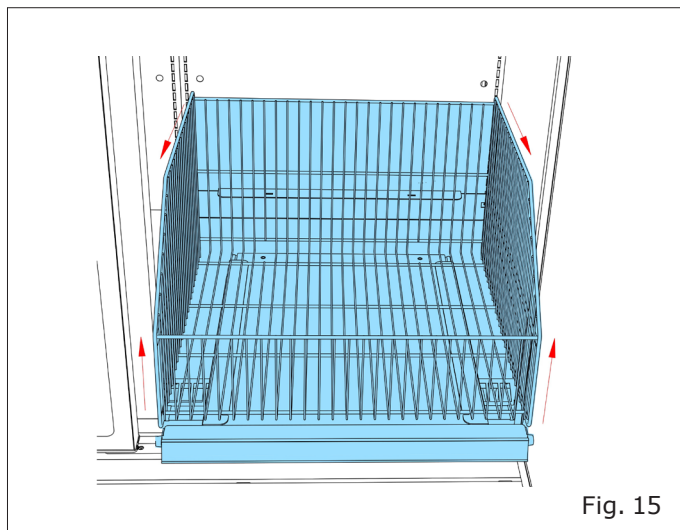

Fig. 15

- Limpie la plataforma base con un trapo húmedo.

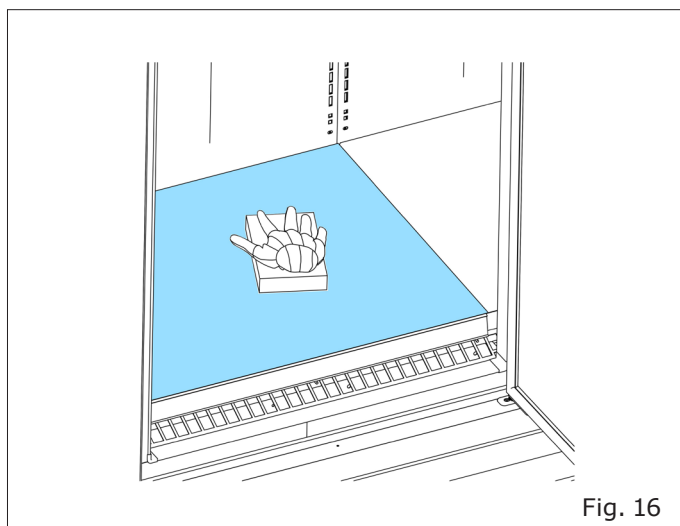

Fig. 16

- Tómallo.

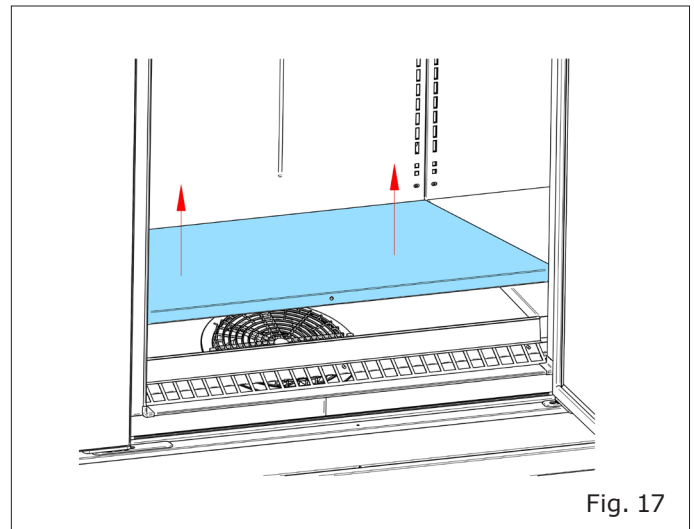

Fig. 17

- Retire la rejilla de retorno de aire y la rejilla de descarga de aire y límpielas con un trapo húmedo.

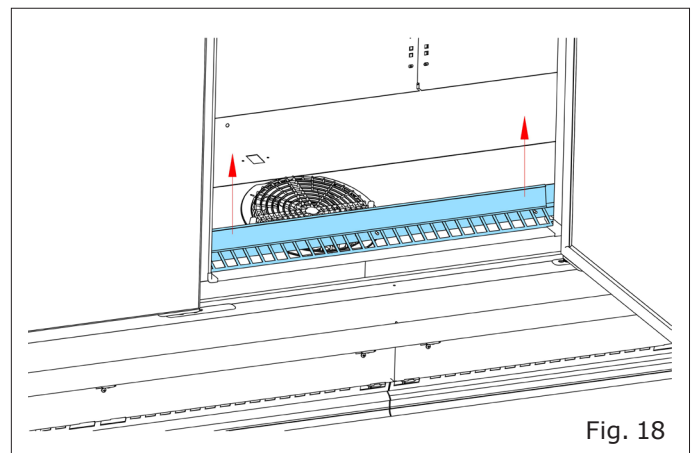

Fig. 18

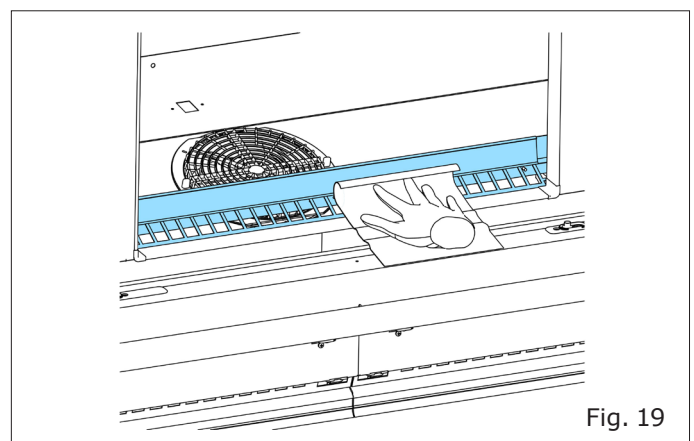

Fig. 19



¡Tenga cuidado con los ventiladores rotatorios del evaporador! No los toque con los dedos, trapos u otras herramientas.

Modello - Modèle - Model Modell - Modelo - Modelo	GRANBERING INTEGRAL ULTRA	COSTAN eptarefrigeration
Fabbricante - Constructeur - Manufacturer Hersteller - Fabricante - Fabricante	Epta Spa - Via Mecenate, 86 - 20138 Milano (MI) ITALIA Tel. 02/55403211 Telefax 02/55401023	10/11

Cleaning instruction

IT
FR
EN
DE
ES
PT

- Limpie la bandeja base con jabón suave o detergente en agua tibia. Compruebe que el desagüe no esté obstruido.
- Vuelva a instalar la rejilla de retorno de aire.

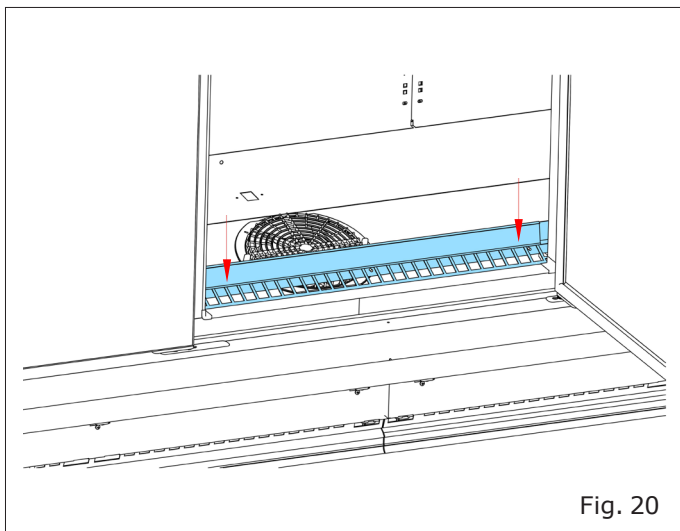

Fig. 20

- Vuelva a instalar la plataforma base.

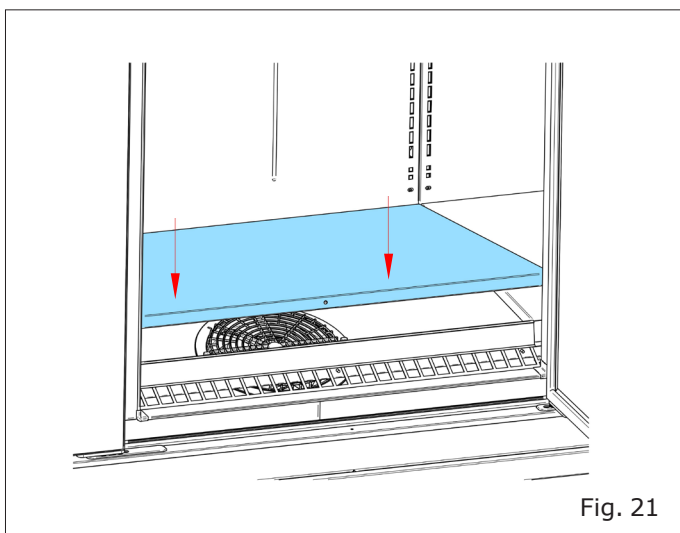

Fig. 21

- Vuelva a instalar la cesta como se describe en el capítulo "Retiro de la canasta".

3.5 Limpieza del condensador

- retire las cubiertas del condensador.

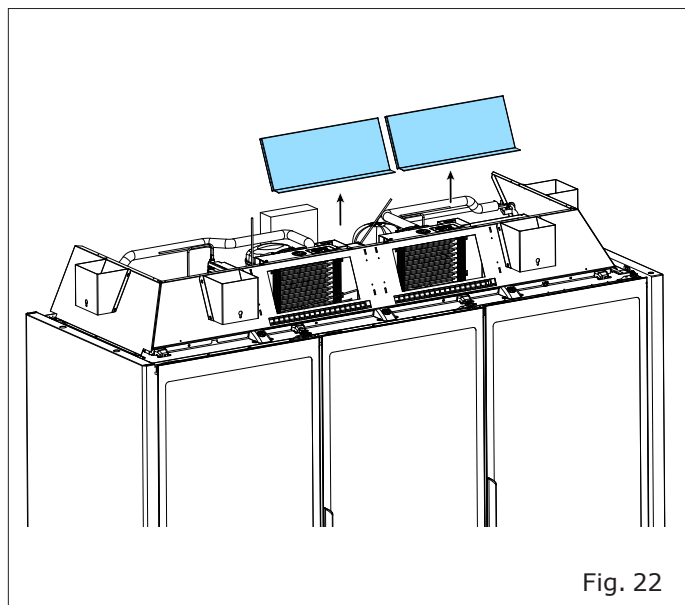

Fig. 22

- Limpie el condensador con una aspiradora industrial o un cepillo de mano.

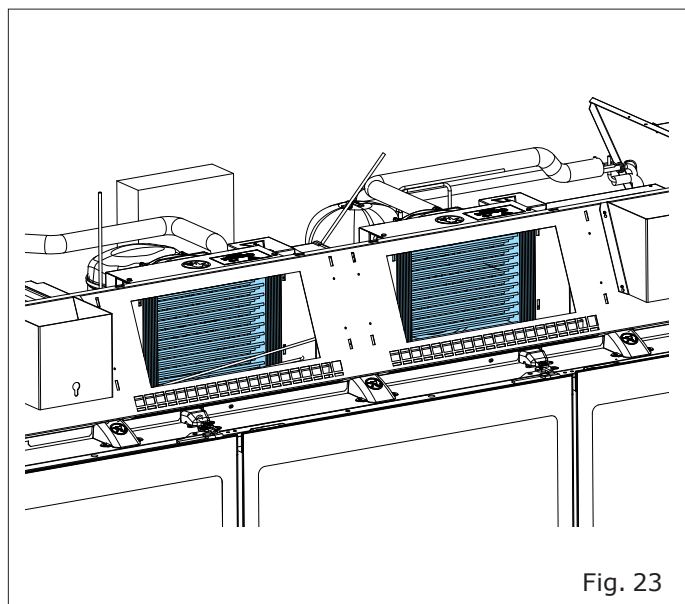
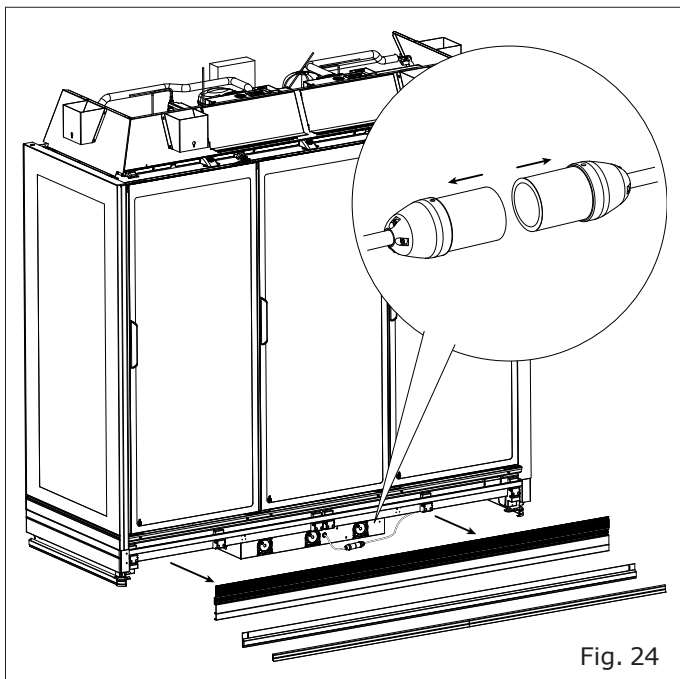

Fig. 23

Modello - Modèle - Model Modell - Modelo - Modelo	GRANBERING INTEGRAL ULTRA	COSTAN eptarefrigeration
Fabbricante - Constructeur - Manufacturer Hersteller - Fabricante - Fabricante	Epta Spa - Via Mecenate, 86 - 20138 Milano (MI) ITALIA Tel. 02/55403211 Telefax 02/55401023	11/11

3.6 Limpieza de la bandeja de evaporación de agua

- Retire la cubierta frontal haciendo palanca.
- Desconecte el cable de alimentación.



- Saque la bandeja de agua.

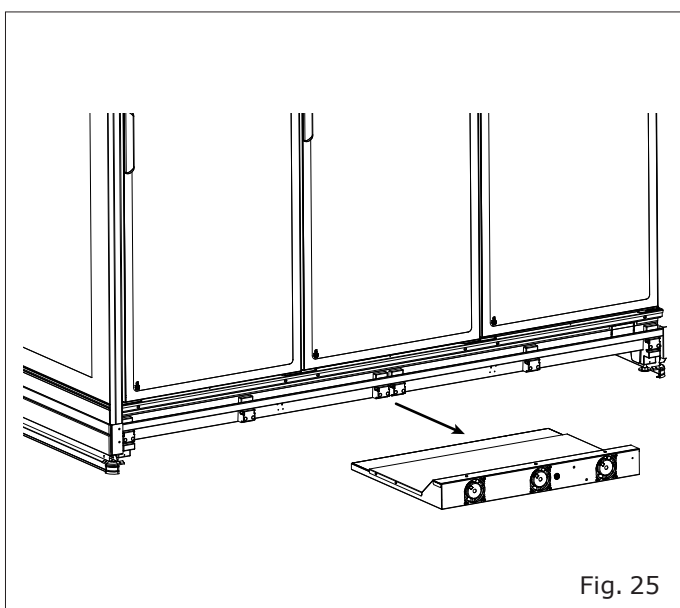

- Quite los tornillos y retire el panel superior.
- Limpie la bandeja de agua.

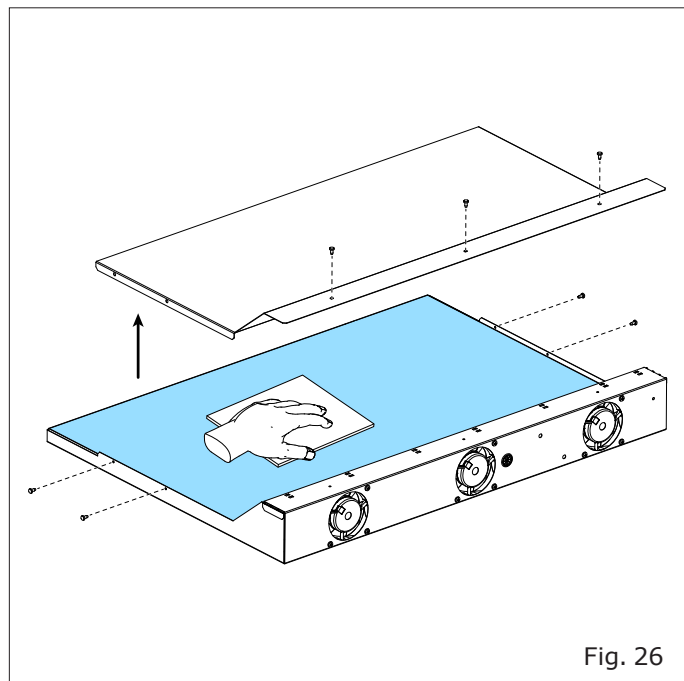

3.7 Reinicio del gabinete

- Después de completar la limpieza y verificar atentamente que el interior del mueble está completamente seco, vuelva a poner en funcionamiento el aparato volviendo a conectar la alimentación al mueble.
- El gabinete entonces comenzará su ciclo de enfriamiento. Permita que los gabinetes alcancen una temperatura mostrada de -18°C antes de volver a cargar las mercancías retiradas.

Modello - Modèle - Model Modell - Modelo - Modelo	GRANBERING INTEGRAL ULTRA	COSTAN <small>eptarefrigeration</small>
Fabbricante - Constructeur - Manufacturer Hersteller - Fabricante - Fabricante	Epta Spa - Via Mecenate, 86 - 20138 Milano (MI) ITALIA Tel. 02/55403211 Telefax 02/55401023	2/11

Cleaning instruction

ÍNDICE

IT
FR
EN
DE
ES
PT

1. Introdução	3
1.1 Alcance	3
1.2 Informações gerais de segurança	3
1.3 Motivos da limpeza	3
2. Agentes de limpeza	4
3. Limpando o aparelho	5
3.1 Limpeza do exterior do expositor refrigerado	5
3.2 Limpeza do interior da vitrine refrigerada	5
3.3 Retirada da cesta	6
3.4 Limpeza do deck base	9
3.5 Limpeza do condensador	10
3.6 limpeza da bandeja de evaporação de água	11
3.7 Reinício do gabinete	11

SIMBOLOGIA UTILIZADA



Símbolo proibição: proíbe efetuar determinadas operações.



Símbolo atenção: normas contra acidentes para o operador.



Símbolo advertências: existe a possibilidade de danificar o balcão e/ou os seus componentes.



Símbolo nota: fornece informações úteis.

Equipamento de proteção pessoal

	Sapatos de segurança
	Luvas de proteção
	Óculos de segurança
	Capacete de segurança
	Coletes de segurança

Modello - Modèle - Model Modell - Modelo - Modelo	GRANBERING INTEGRAL ULTRA	COSTAN <small>eptarefrigeration</small>
Fabbricante - Constructeur - Manufacturer Hersteller - Fabricante - Fabricante	Epta Spa - Via Mecenate, 86 - 20138 Milano (MI) ITALIA Tel. 02/55403211 Telefax 02/55401023	3/11

1. INTRODUÇÃO

1.1 Alcance

O documento "Cleaning Instructions" indica como limpar um expositor de produtos refrigerados para alimentos congelados.

As instruções de uso também estão disponíveis em:

www.eptarefrigeration.com.

1.2 Informações gerais de segurança



Nunca interrompa a cadeia de refrigeração dos produtos expostos.



Antes de iniciar qualquer manutenção ou limpeza, desconecte o equipamento da rede elétrica e proteja-o contra religação por pessoas não autorizadas.



Certifique-se de que a área de trabalho esteja suficientemente iluminada durante as atividades de manutenção e limpeza e use uma fonte de iluminação adicional, se necessário.



As portas e paredes de vidro são fornecidas com uma película anti-embaciamento no interior. Não use nenhum detergente que contenha substâncias abrasivas, fortemente ácidas ou cáusticas.



Cuidado ao tocar em qualquer parte rotativa do gabinete (ventiladores) com os dedos, toalhas ou outras ferramentas.



Não remova quaisquer proteções e tampas de proteção.

1.3 Motivos da limpeza

Para apresentar os produtos de forma atrativa e higiênica, é importante limpar regularmente o gabinete do freezer. A limpeza regular também evita que o mofo e as bactérias nocivas se instalem nos móveis, pois a poeira úmida é um terreno fértil ideal.

A limpeza regular também é essencial para a função técnica. Esta é a única maneira de garantir que ocorra uma troca de calor ideal e que o ar possa fluir facilmente no gabinete.

IT

FR

EN

DE

ES

PT

Modello - Modèle - Model Modell - Modelo - Modelo	GRANBERING INTEGRAL ULTRA	COSTAN  <small>eptarefrigeration</small>
Fabbricante - Constructeur - Manufacturer Hersteller - Fabricante - Fabricante	Epta Spa - Via Mecenate, 86 - 20138 Milano (MI) ITALIA Tel. 02/55403211 Telefax 02/55401023	4/11

Cleaning instruction

IT

2. AGENTES DE LIMPEZA

FR

Roupas de trabalho

- Luvas de proteção
- Roupa de proteção
- Óculos de segurança

EN

DE

ES

Agente de limpeza para superfícies que não sejam vidro

PT

- Água
- Detergente suave
- Esponjas, panos e panos macios que não arranhem

Agente de limpeza para superfícies de vidro

- Água
- Detergente suave
- Limpador de vidro padrão
- Removedores de manchas de óleo
- Esponjas, panos e toalhas de papel que não riscam

O seguinte não deve ser usado

- Agentes de limpeza corrosivos fortes
- Agentes de limpeza ácidos ou cáusticos
- Agentes inflamáveis
- Acetona
- Agentes de limpeza contendo solvente
- Limpadores abrasivos
- Limpador de lavagem a jato ou outro jato de água forte para limpar

Modello - Modèle - Model Modell - Modelo - Modelo	GRANBERING INTEGRAL ULTRA	COSTAN eptarefrigeration
Fabbricante - Constructeur - Manufacturer Hersteller - Fabricante - Fabricante	Epta Spa - Via Mecenate, 86 - 20138 Milano (MI) ITALIA Tel. 02/55403211 Telefax 02/55401023	5/11

3. LIMPANDO O APARELHO

3.1 Limpeza do exterior do expositor refrigerado

- Limpe as superfícies externas da vitrine com sabão neutro ou detergente apenas em água morna.
- Limpe cuidadosamente com esponjas, panos e panos macios que não risquem.

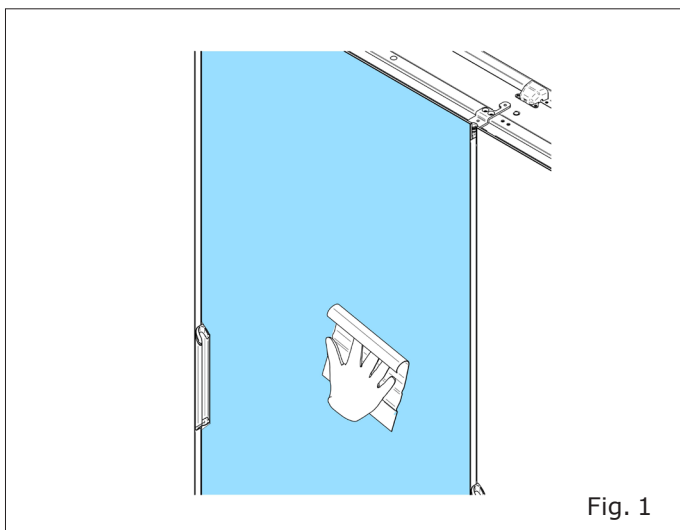

Limpeza das portas de vidro e paredes de vidro no interior:

- Limpe-o usando um limpador de vidro padrão com uma esponja não abrasiva, um pano ou uma toalha de papel.

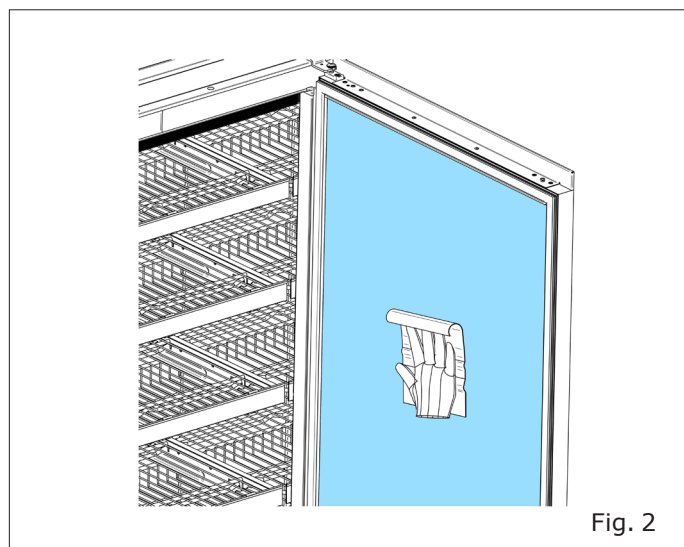

 Resíduos gordurosos devem ser removidos com removedor de manchas de óleo.

3.2 Limpeza do interior da vitrine refrigerada

- Remova os produtos exibidos em câmaras frigoríficas ou câmaras frigeríficas.
- Evite interromper a cadeia de refrigeração.
- Desconecte o gabinete da fonte de alimentação elétrica e proteja-o contra reconexão por pessoas não autorizadas.

Limpeza das prateleiras:

- As superfícies podem ser limpas com sabão neutro ou detergente em água morna.

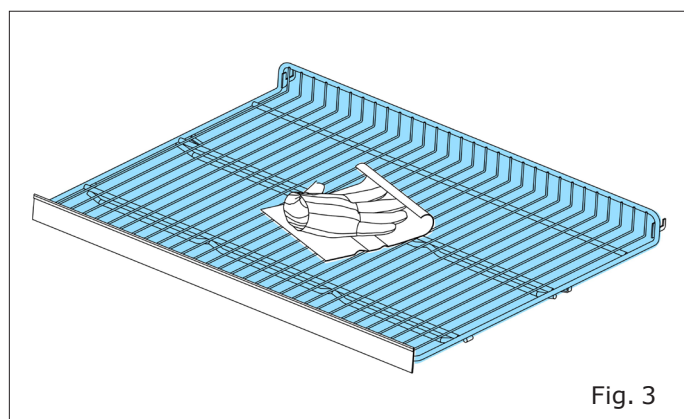

Cleaning instruction

- Para uma limpeza conveniente, você pode destacar as prateleiras e retirá-las do rack.

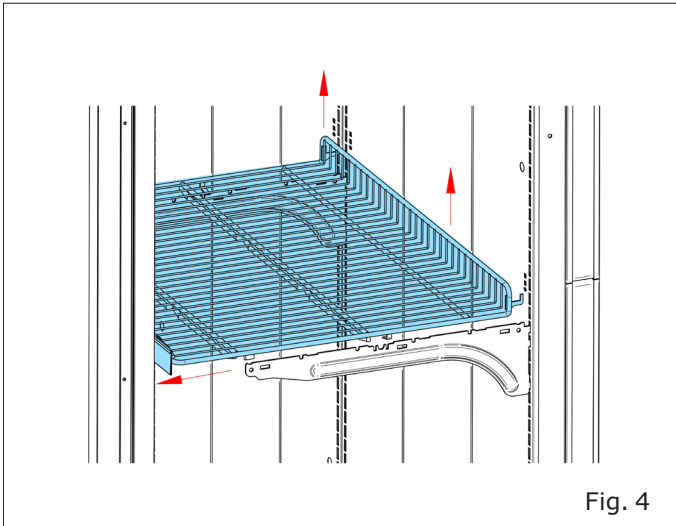

Por favor, gire a prateleira para extraí-la do armário.

- Certifique-se de que os suportes estão na posição correta e que os suportes travam completamente no suporte ao reinstalá-los.

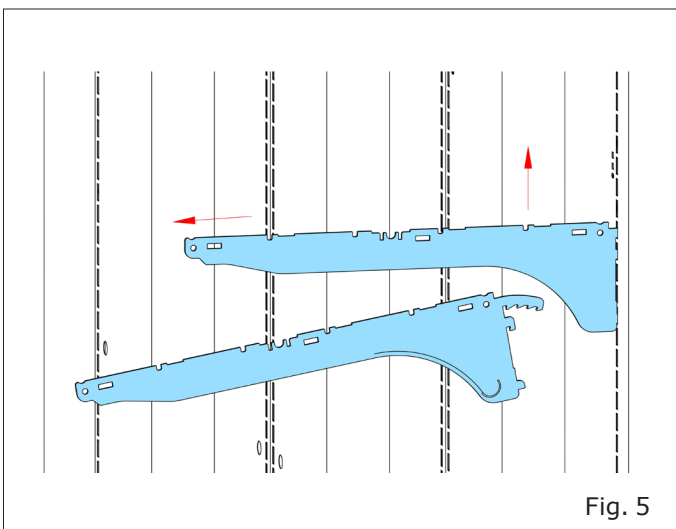

Limpeza da grelha de retorno de ar:

- Limpe a grelha de retorno de ar com um aspirador e/ou limpe a grelha com um pano húmido.

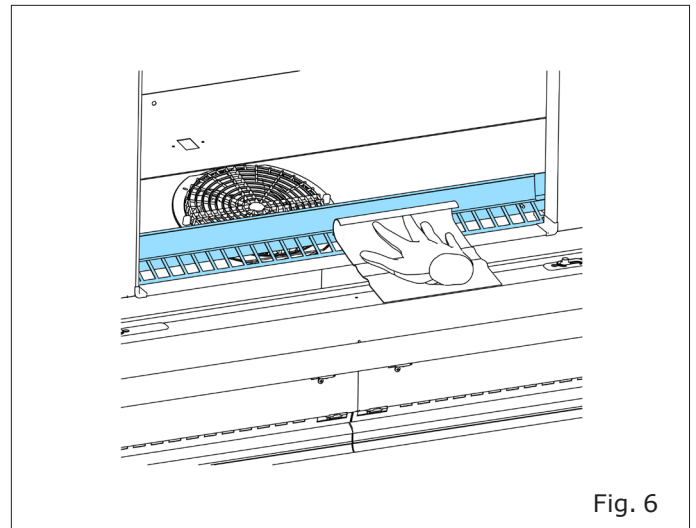

3.3 Retirada da cesta

- A arca congeladora pode ser fornecida com um cesto extraível.

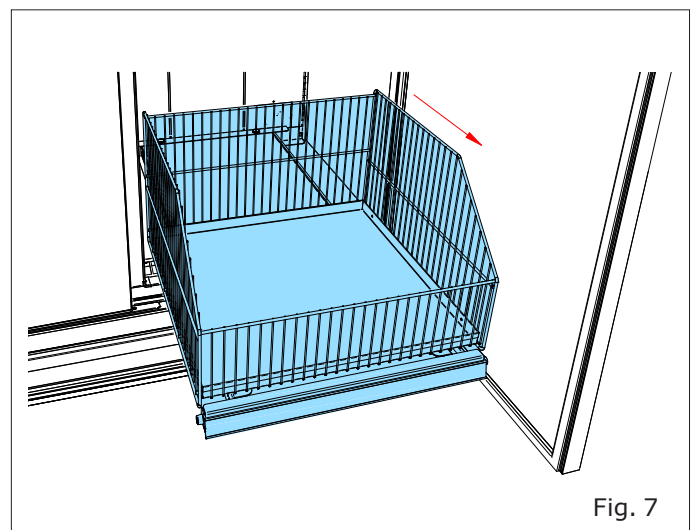

- Isso pode ser removido para limpeza.
- Para fazer isso, retire a cesta do gabinete e remova as duas porcas serrilhadas. A cesta pode então ser removida.

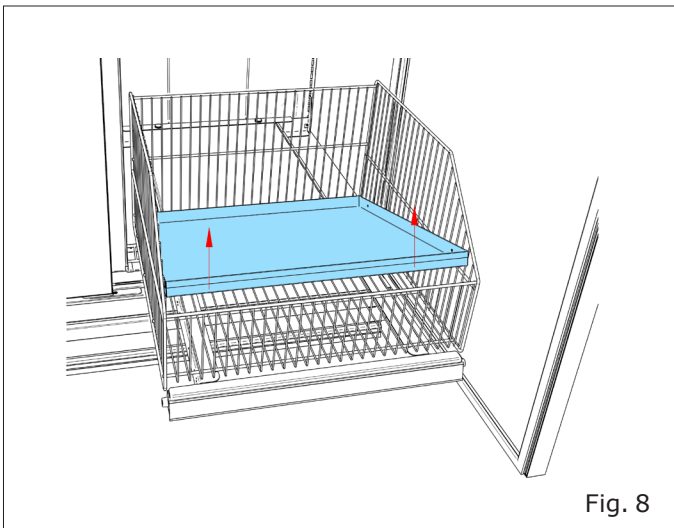

Remova o painel interno.

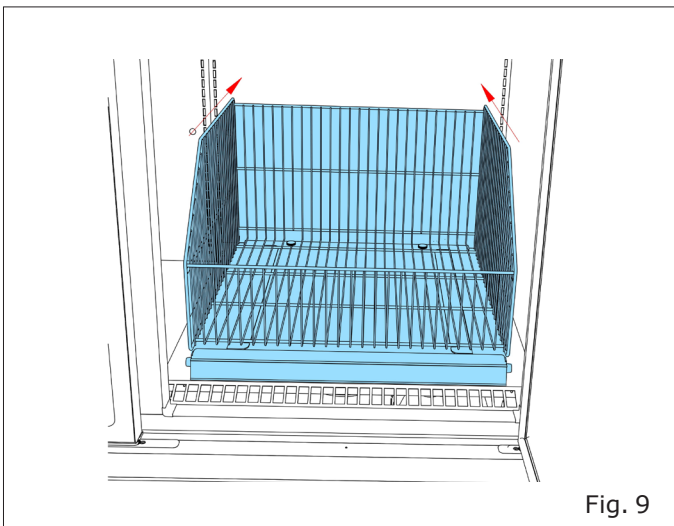

Coloque a cesta dentro para remover as porcas serrilhadas.

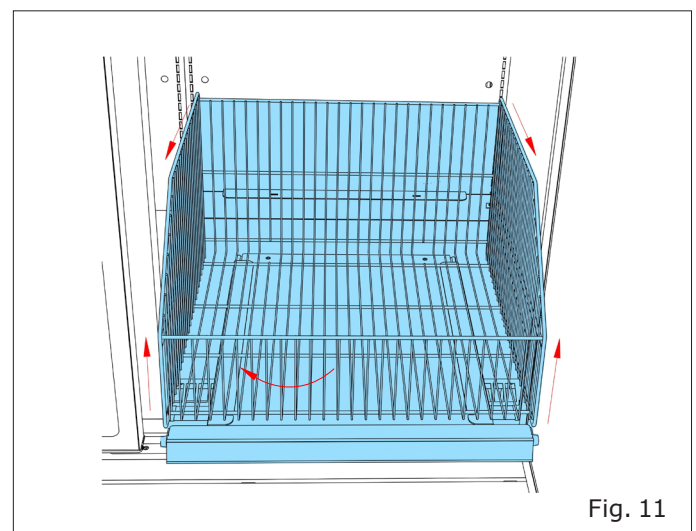
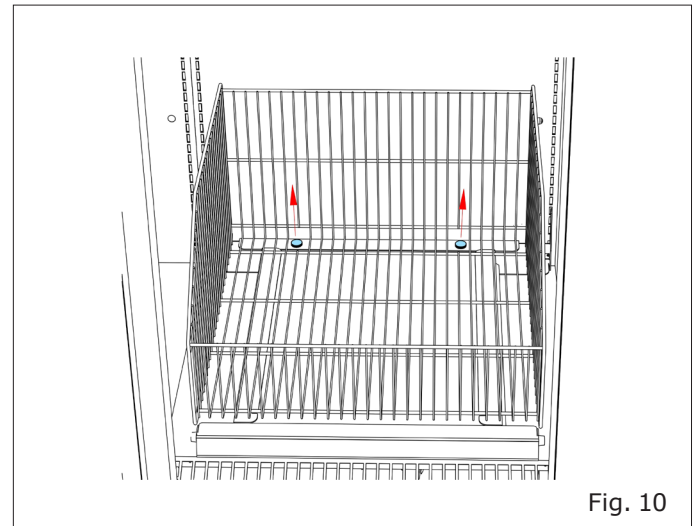

IT

FR

EN

DE

ES

PT

Modello - Modèle - Model Modell - Modelo - Modelo	GRANBERING INTEGRAL ULTRA	
Fabbricante - Constructeur - Manufacturer Hersteller - Fabricante - Fabricante	Epta Spa - Via Mecenate, 86 - 20138 Milano (MI) ITALIA Tel. 02/55403211 Telefax 02/55401023	8/11

Cleaning instruction

IT
FR
EN
DE
ES
PT

- Reinstale a cesta na ordem inversa. Alinhe o cesto e fixe-o com as porcas serrilhadas.
- Guarde as porcas serrilhadas com cuidado e substitua-as após a limpeza para fixar a cesta.

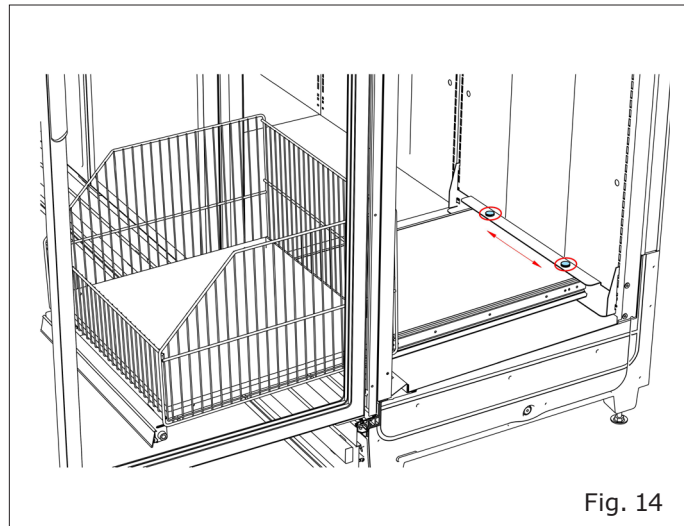
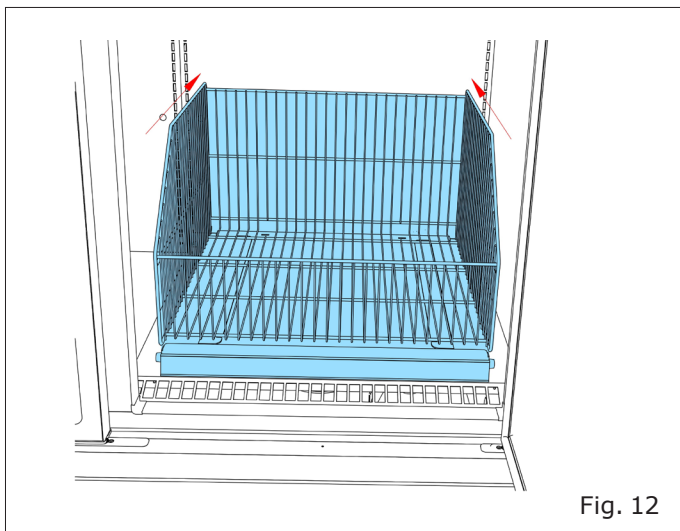

 Verifique cuidadosamente se a cesta não tocará em nenhuma moldura ou vedação da vitrine ou porta.

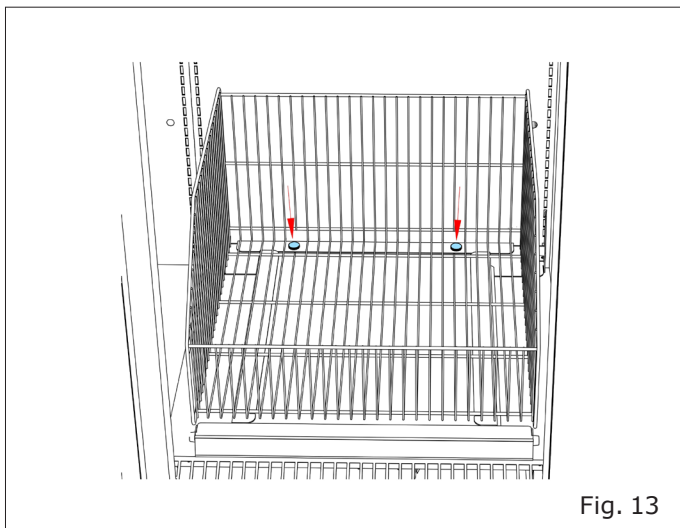

3.4 Limpeza do deck base



A limpeza do deck de base deve ser feita apenas por pessoal treinado.

- Remova os produtos exibidos em câmaras frigoríficas ou câmaras frigoríficas.
- Evite interromper a cadeia de refrigeração.
- Desconecte o gabinete da fonte de alimentação elétrica e proteja-o contra reconexão por pessoas não autorizadas.
- Remova o cesto removível conforme descrito no capítulo "Retirada da cesta".

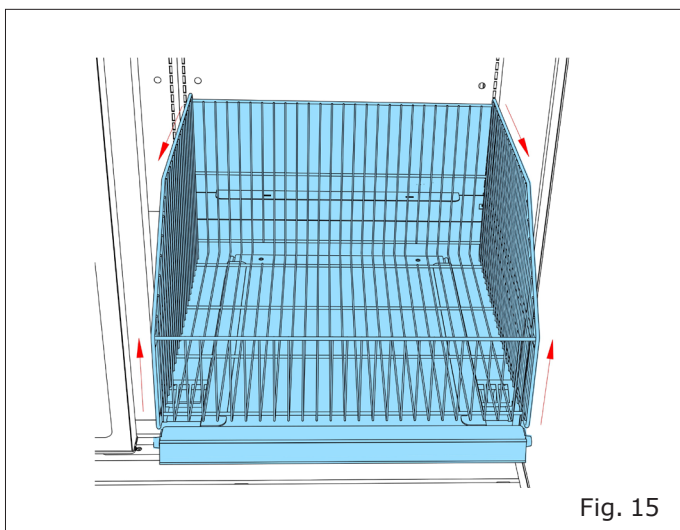

Fig. 15

- Limpe o deck de base usando um pano úmido.

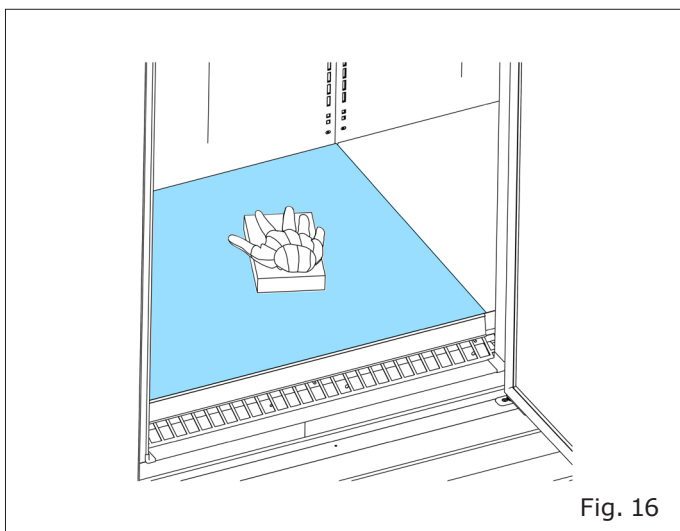

Fig. 16

- Tire.

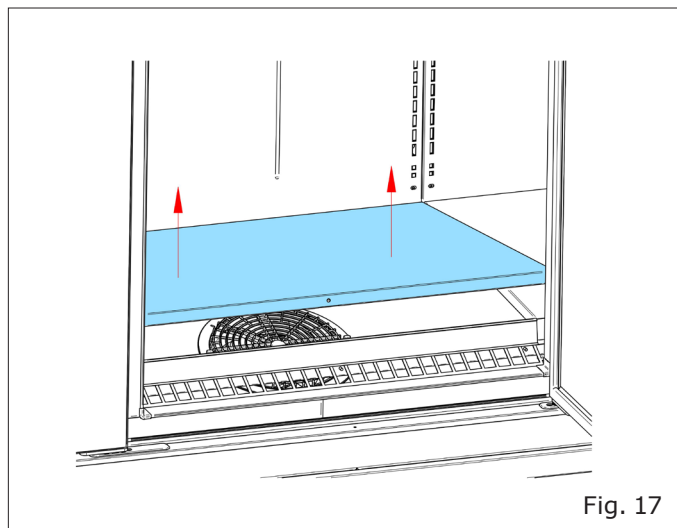

Fig. 17

- Remova a grelha de retorno de ar e a grelha de descarga de ar e limpe-as com um pano húmido.

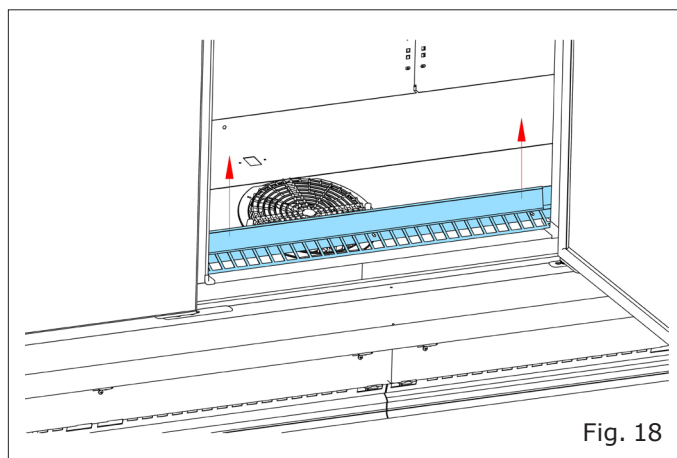

Fig. 18

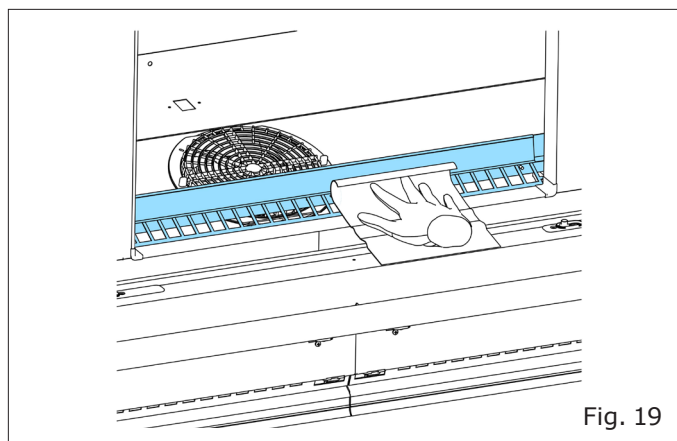

Fig. 19



Esteja ciente dos ventiladores rotativos do evaporador! Não os toque com o dedo, trapos ou outras ferramentas.

Modello - Modèle - Model Modell - Modelo - Modelo	GRANBERING INTEGRAL ULTRA	COSTAN eptarefrigeration
Fabbricante - Constructeur - Manufacturer Hersteller - Fabricante - Fabricante	Epta Spa - Via Mecenate, 86 - 20138 Milano (MI) ITALIA Tel. 02/55403211 Telefax 02/55401023	10/11

Cleaning instruction

IT
FR
EN
DE
ES
PT

- Limpe a bandeja da base com sabão neutro ou detergente em água morna. Verifique se o dreno está desobstruído.
- Reinstale a grade de retorno de ar.

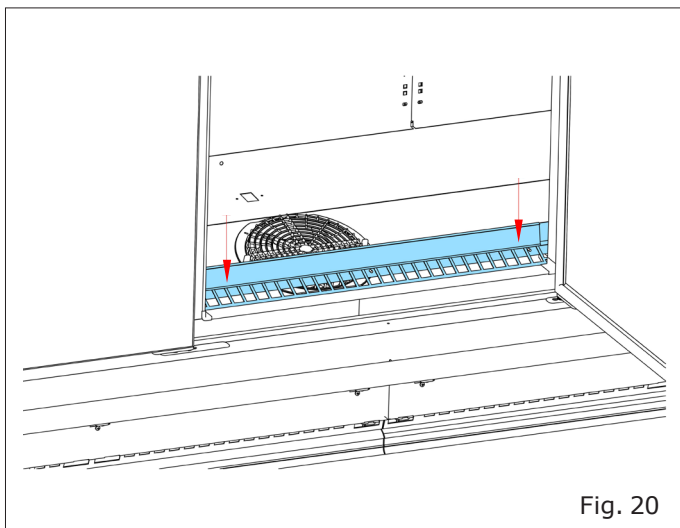

Fig. 20

- Reinstale o deck de base.

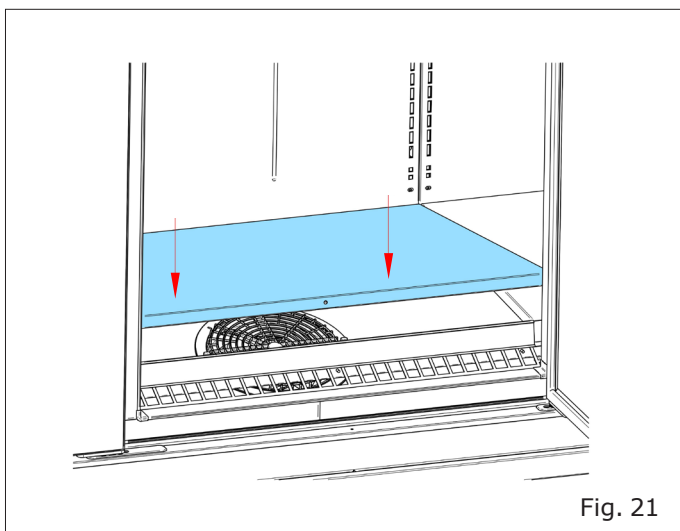

Fig. 21

- Reinstale a cesta conforme descrito no capítulo "Retirada da cesta".

3.5 Limpeza do condensador

- Remova as tampas do condensador.

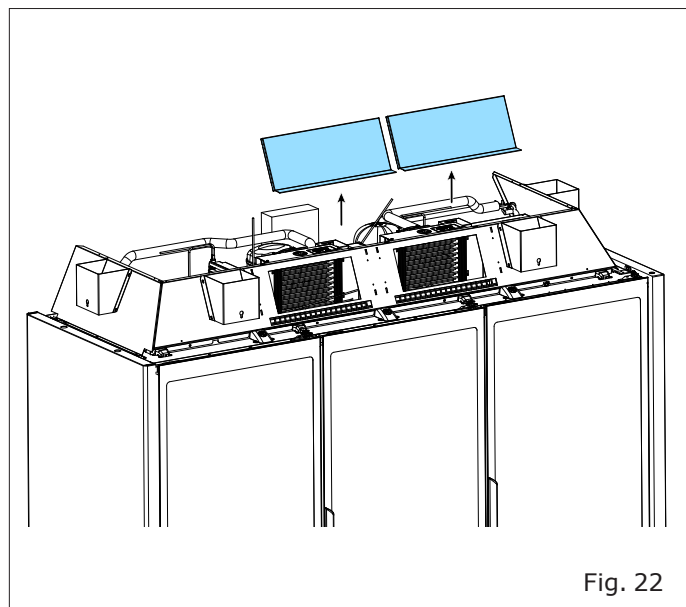

Fig. 22

- Limpe o condensador com um aspirador industrial ou uma escova manual.

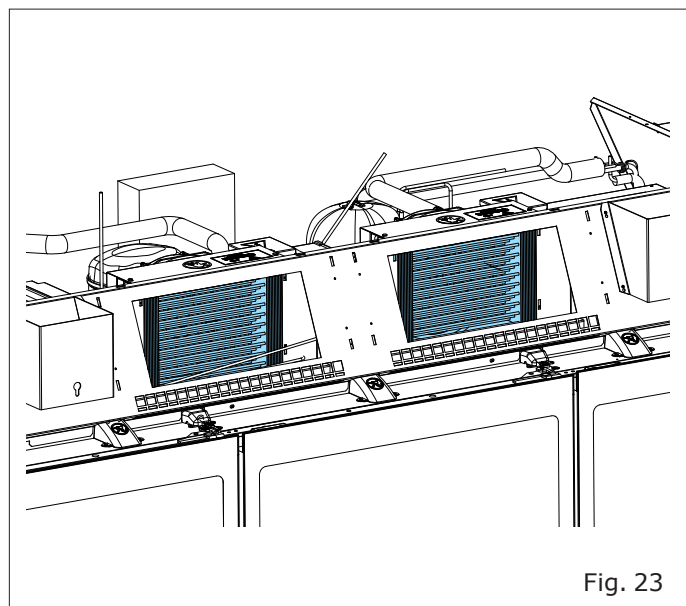
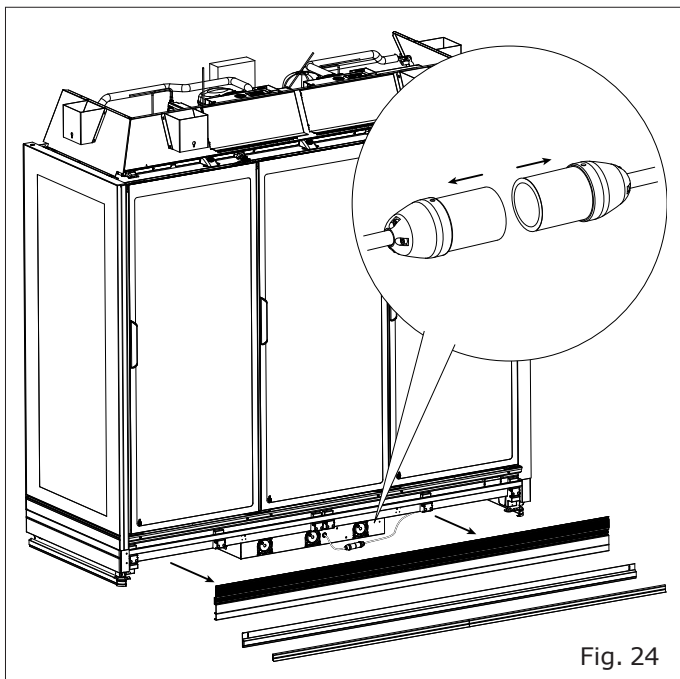

Fig. 23

Modello - Modèle - Model Modell - Modelo - Modelo	GRANBERING INTEGRAL ULTRA	COSTAN eptarefrigeration
Fabbricante - Constructeur - Manufacturer Hersteller - Fabricante - Fabricante	Epta Spa - Via Mecenate, 86 - 20138 Milano (MI) ITALIA Tel. 02/55403211 Telefax 02/55401023	11/11

3.6 limpeza da bandeja de evaporação de água

- Remova a tampa frontal levantando-a.
- Desconecte o cabo de alimentação.+



- Puxe a bandeja de água.

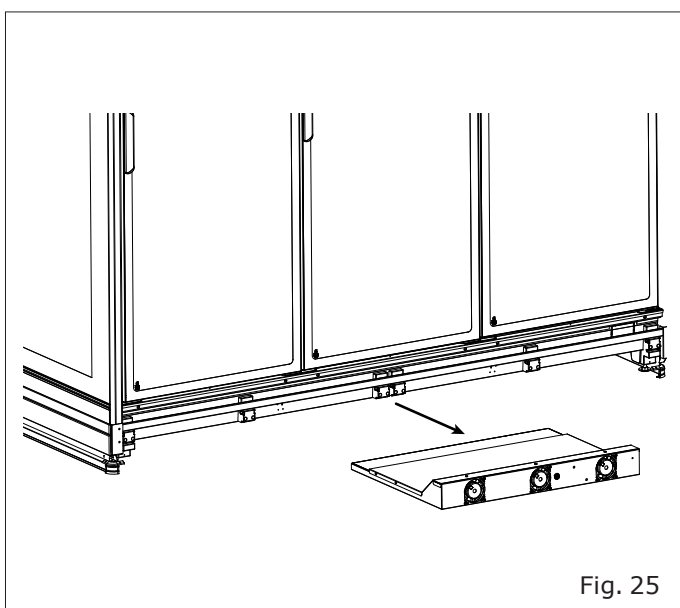

- Desaperte os parafusos e remova o painel superior.
- Limpe a bandeja de água.

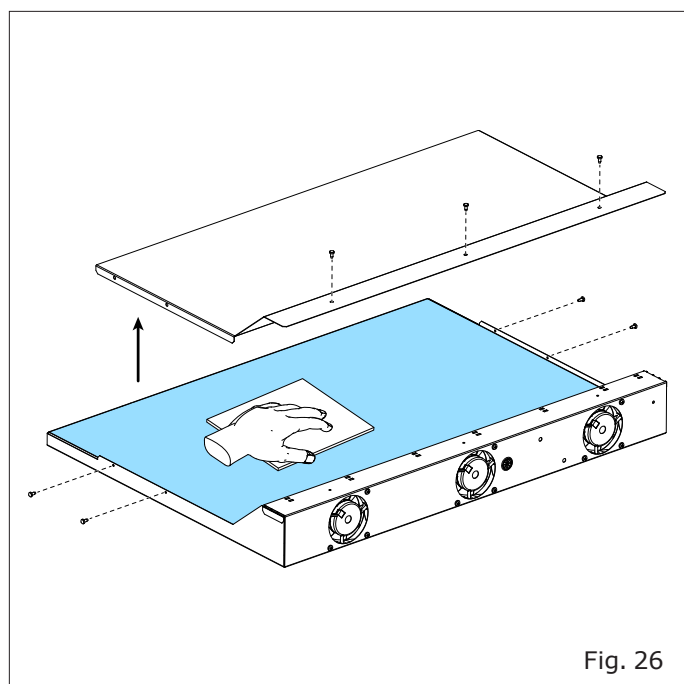

3.7 Reinício do gabinete

- Após concluir a limpeza e verificar atentamente se o interior do gabinete está completamente seco, coloque o aparelho novamente em operação, reconectando a energia ao gabinete.
- O gabinete iniciará então seu ciclo de resfriamento. Permita que os gabinetes atinjam uma temperatura exibida de -18°C antes de recarregar as mercadorias removidas.

COSTAN 
eptarefrigeration
www.costan.com

Epta
Advanced Solutions
for your Store

Epta S.p.A. participates in the ECC programme for:
Refrigerated display cabinets (RDC). Check ongoing validity
of certificate online: www.eurovent-certification.com

EN ISO 9001
EN ISO 14001
EN ISO 45001
CERTIFIED



www.eptarefrigeration.com