

GRANVISTA INTEGRAL AIR

CLEANING INSTRUCTION

Modello - Modèle - Model Modell - Modelo - Modelo	GRANVISTA INTEGRAL AIR	COSTAN eptarefrigeration
Fabbricante - Constructeur - Manufacturer Hersteller - Fabricante - Fabricante	Epta Spa - Via Mecenate, 86 - 20138 Milano (MI) ITALIA Tel. 02/55403211 Telefax 02/55401023	2/10

Cleaning instruction

IT
FR
EN
DE
ES
PT

INDICE

1. Introduzione	2
1.1 Introduzione	2
1.2 Informazioni generali di sicurezza	2
1.3 Motivi per la pulizia	2
2. Materiali e detergenti	3
3. Pulizia dell'apparecchiatura	4
3.1 Pulizia dell'esterno dell'apparecchiatura	4
3.2 Pulizia dell'interno dell'apparecchiatura	4
3.3 Pulizia del piano di fondo	6
3.4 Pulizia del condensatore	8
3.5 Assemblaggio del banco	9
3.6 Riaccensione del banco	9

SIMBOLOGIA UTILIZZATA



Simbolo divieto: vieta di effettuare determinate operazioni.



Simbolo attenzione: norme antinfortunistiche per l'operatore.



Simbolo avvertenze: esiste la possibilità di arrecare danno al banco e/o ai suoi componenti.



Simbolo nota: fornisce informazioni utili.

Dispositivi di protezione individuali

	Scarpe antinfortunistiche
	Guanti protettivi
	Occhiali di sicurezza
	Elmetto di sicurezza
	Gilet catarifrangente

Modello - Modèle - Model Modell - Modelo - Modelo	GRANVISTA INTEGRAL AIR	COSTAN eptarefrigeration
Fabbricante - Constructeur - Manufacturer Hersteller - Fabricante - Fabricante	Epta Spa - Via Mecenate, 86 - 20138 Milano (MI) ITALIA Tel. 02/55403211 Telefax 02/55401023	3/10

1. INTRODUZIONE

1.1 Introduzione

Il documento "Cleaning Instructions" indica come pulire il banco refrigerato. Contiene inoltre informazioni su come tutelare l'incolumità degli addetti alle pulizie.

Le istruzioni d'uso sono disponibili anche su:
www.eptarefrigeration.com.

1.2 Informazioni generali di sicurezza



Non interrompere la catena del freddo dei prodotti esposti.



Prima di qualsiasi operazione di manutenzione e pulizia, disconnettere il banco dalla rete elettrica ed assicurarsi che il personale non autorizzato possa riconnettere l'alimentazione elettrica.



Assicurarsi che la zona di lavoro sia sufficientemente illuminata durante le operazioni di pulizia e manutenzione. Utilizzare ulteriori fonti di illuminazione se necessario.



Le porte e le pareti in vetro sono dotate all'interno di una pellicola antiappannamento. Non utilizzare detergenti contenenti sostanze abrasive, fortemente acide o caustiche.



Fare attenzione a non toccare parti in rotazione del banco (ventolatori) con le dita, asciugamani o altri strumenti.



Non rimuovere le protezioni e le coperture di protezione.

1.3 Motivi per la pulizia

Per presentare le merci in modo attraente e igienico, è importante pulire regolarmente il banco. Una pulizia regolare impedisce inoltre che muffe e batteri nocivi si depositino nel banco, poiché la polvere umida fornisce un terreno fertile ideale.

La pulizia regolare è essenziale anche per la funzione tecnica. Questo è l'unico modo per garantire uno scambio termico ottimale e che l'aria possa fluire facilmente nel banco.

IT

FR

EN

DE

ES

PT

Modello - Modèle - Model Modell - Modelo - Modelo	GRANVISTA INTEGRAL AIR	COSTAN  eptarefrigeration
Fabbricante - Constructeur - Manufacturer Hersteller - Fabricante - Fabricante	Epta Spa - Via Mecenate, 86 - 20138 Milano (MI) ITALIA Tel. 02/55403211 Telefax 02/55401023	4/10

- IT
- FR
- EN
- DE
- ES
- PT

2. MATERIALI E DETERGENTI

Abiti da lavoro

- Guanti protettivi
- Indumenti protettivi
- Occhiali di sicurezza

Detergente per superfici diverse dal vetro

- Acqua
- Detergente delicato
- Spugne, stracci e panni morbidi antigraffio

Detergente per superfici in vetro

- Acqua
- Detergente delicato
- Detergente per vetri standard
- Smacchiatori d'olio
- Spugne, stracci e asciugamani di carta antigraffio

Quanto segue non deve essere utilizzato

- Detergenti fortemente corrosivi
- Detergenti acidi o caustici
- Agenti infiammabili
- Acetone
- Agenti detergenti contenenti solventi
- Detergenti abrasivi
- Detergente a getto d'acqua o altro getto d'acqua forte per pulire

Modello - Modèle - Model Modell - Modelo - Modelo	GRANVISTA INTEGRAL AIR	COSTAN eptarefrigeration
Fabbricante - Constructeur - Manufacturer Hersteller - Fabricante - Fabricante	Epta Spa - Via Mecenate, 86 - 20138 Milano (MI) ITALIA Tel. 02/55403211 Telefax 02/55401023	5/10

3. PULIZIA DELL'APPARECCHIATURA

3.1 Pulizia dell'esterno dell'apparecchiatura

- Lavare l'esterno dell'apparecchiatura solamente con acqua tiepida e sapone neutro o detergente neutro
- Asciugare con cura con spugne non abrasive antigraffio, stracci e panni morbidi

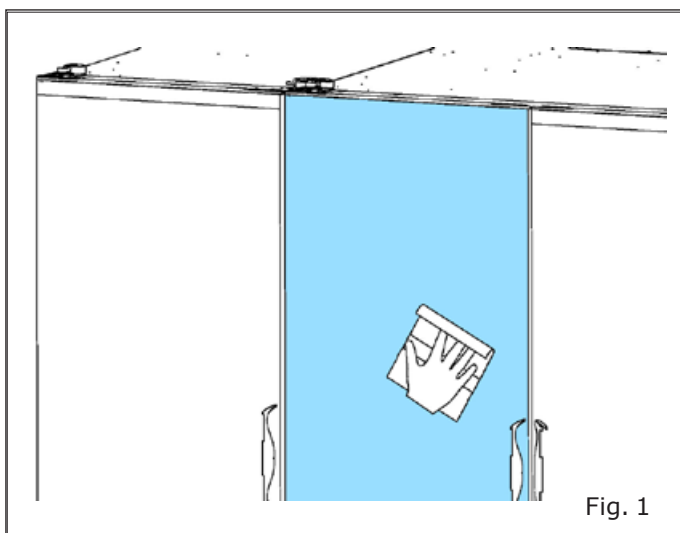

3.2 Pulizia dell'interno dell'apparecchiatura

- Rimuovere i prodotti esposti in frigoriferi o celle frigorifere.
- Evitare le interruzioni nella catena del freddo dei prodotti esposti nell'apparecchiatura
- Disconnettere l'apparecchiatura dalla rete elettrica e assicurare che la riconnessione possa essere effettuata solo da personale autorizzato.

Pulizia delle porte vetrate e delle parti vetrate interne:

- Lavare le parti in vetro con prodotti specifici per vetri e con spugne non abrasive antigraffio, stracci o panni di carta.

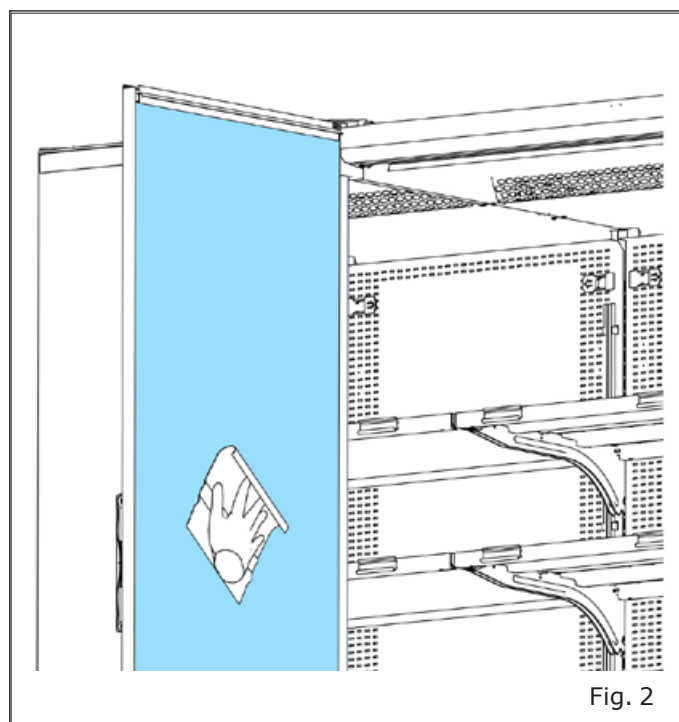

Eventuali residui di grasso devono essere rimossi con specifici smacchiatori.

Pulizia dei ripiani:

- Le superfici devono essere lavate con acqua tiepida e sapone neutro o detergente neutro.

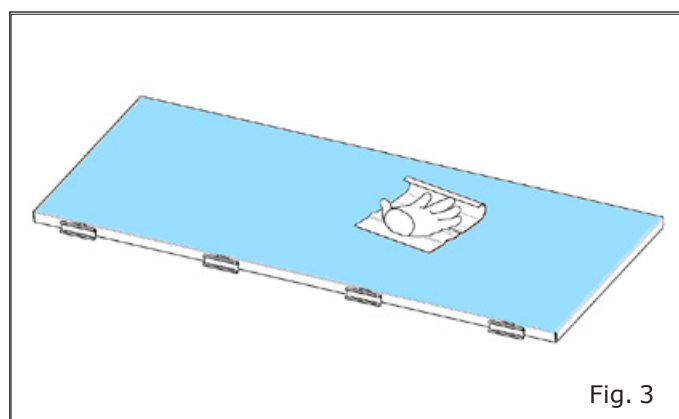

Cleaning instruction

IT

FR

EN

DE

ES

PT

- Per agevolare le operazioni di pulizia è possibile rimuovere i ripiani dalle loro posizioni nella scaffalatura.

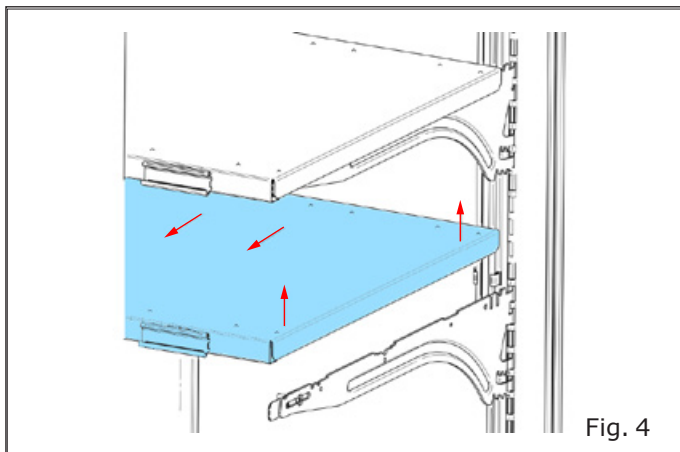

Fig. 4



Ruotare il ripiano prima di estrarlo dal banco.

- Assicurarsi che le staffe di supporto dei ripiani siano nella posizione corretta e completamente bloccate nei loro supporti durante la reinstallazione.

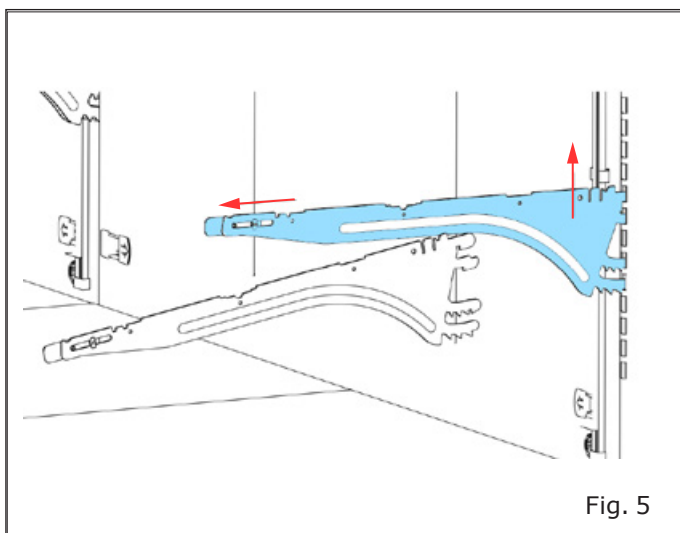

Fig. 5

Rimuovere le la struttura interna

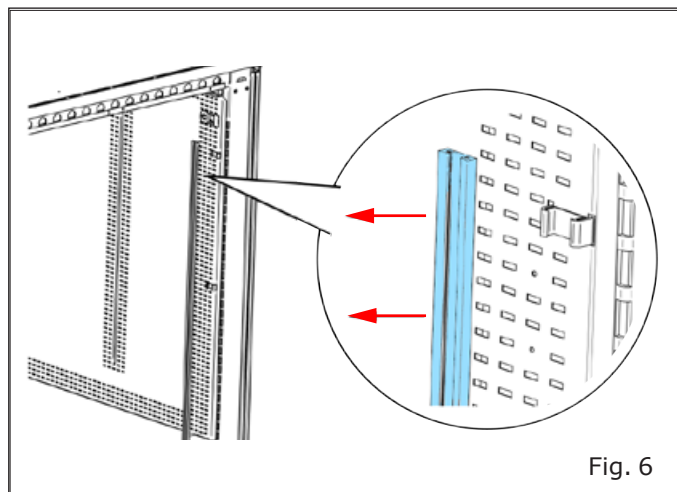

Fig. 6

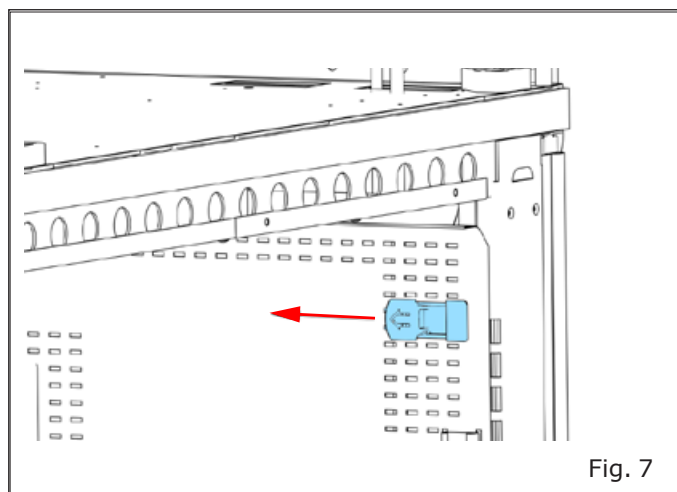

Fig. 7

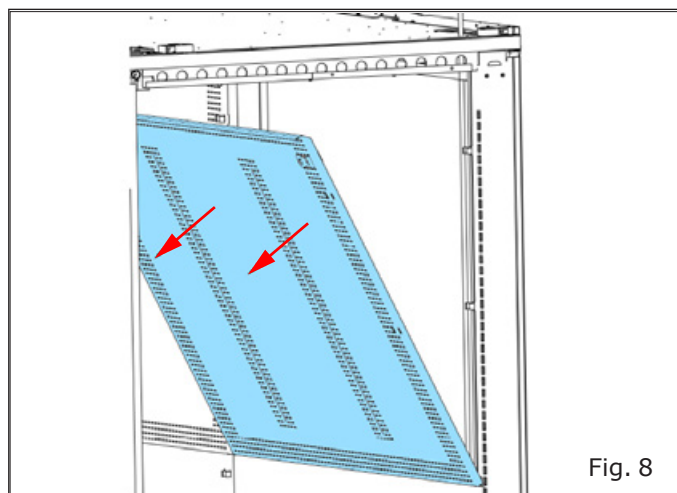

Fig. 8

Modello - Modèle - Model Modell - Modelo - Modelo	GRANVISTA INTEGRAL AIR	COSTAN eptarefrigeration
Fabbricante - Constructeur - Manufacturer Hersteller - Fabricante - Fabricante	Epta Spa - Via Mecenate, 86 - 20138 Milano (MI) ITALIA Tel. 02/55403211 Telefax 02/55401023	7/10

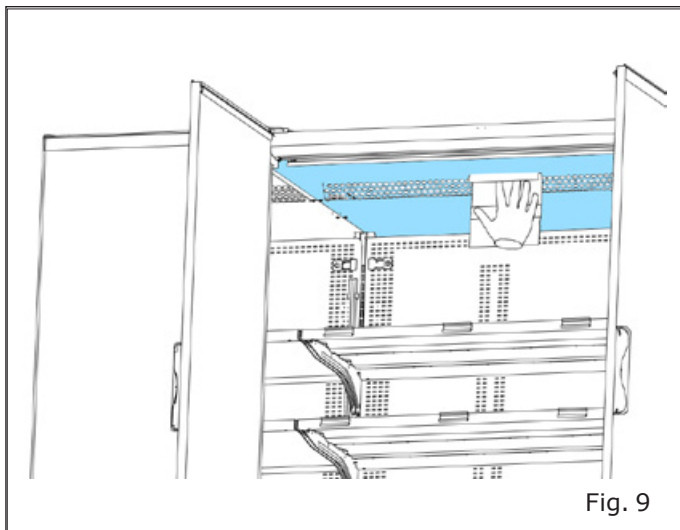

Fig. 9

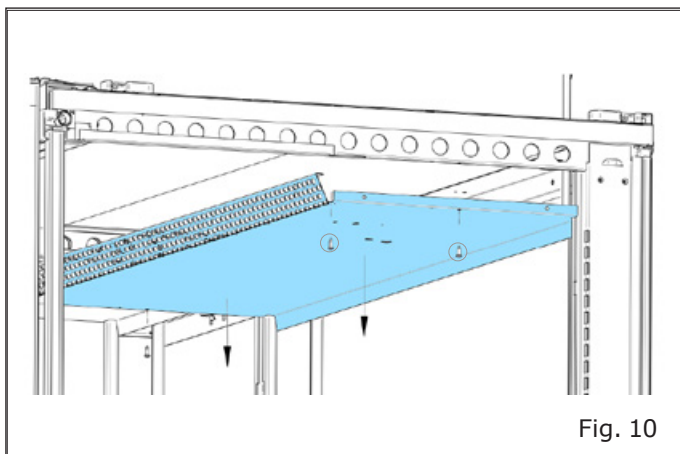

Fig. 10

3.3 Pulizia del piano di fondo



La pulizia del piano di fondo deve essere eseguita solamente da personale addestrato.

- Evitare le interruzioni nella catena del freddo dei prodotti esposti nell'apparecchiatura
- Disconnettere l'apparecchiatura dalla rete elettrica e assicurare che la riconnessione possa essere effettuata solo da personale autorizzato.
- Rimuovere le griglie di ripresa d'aria e pulirle con straccio umido.

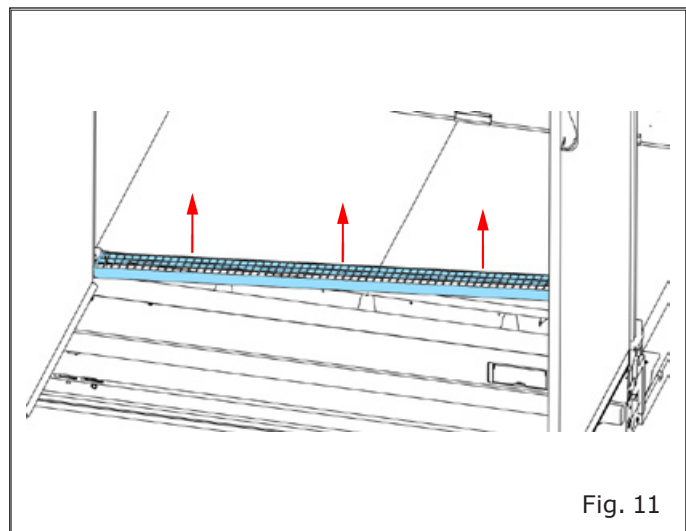

Fig. 11

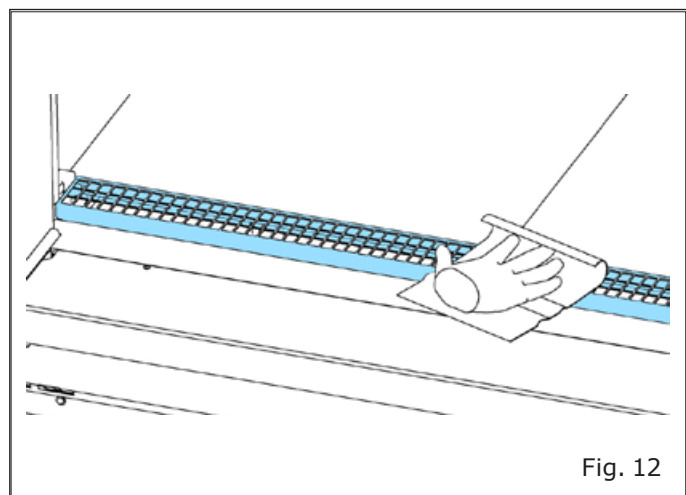

Fig. 12

IT

FR

EN

DE

ES

PT

Modello - Modèle - Model Modell - Modelo - Modelo	GRANVISTA INTEGRAL AIR	COSTAN eptarefrigeration
Fabbricante - Constructeur - Manufacturer Hersteller - Fabricante - Fabricante	Epta Spa - Via Mecenate, 86 - 20138 Milano (MI) ITALIA Tel. 02/55403211 Telefax 02/55401023	8/10

Cleaning instruction

IT
FR
EN
DE
ES
PT

- Estrarre il piano di fondo.

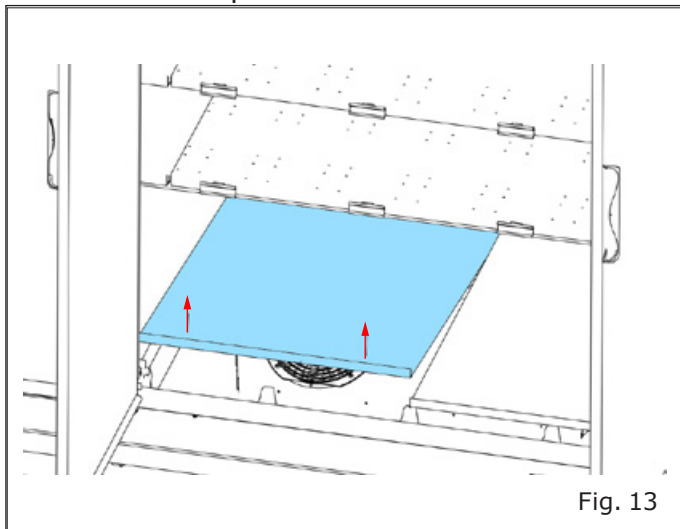

Fig. 13

- Pulire il piano di fondo con straccio umido.

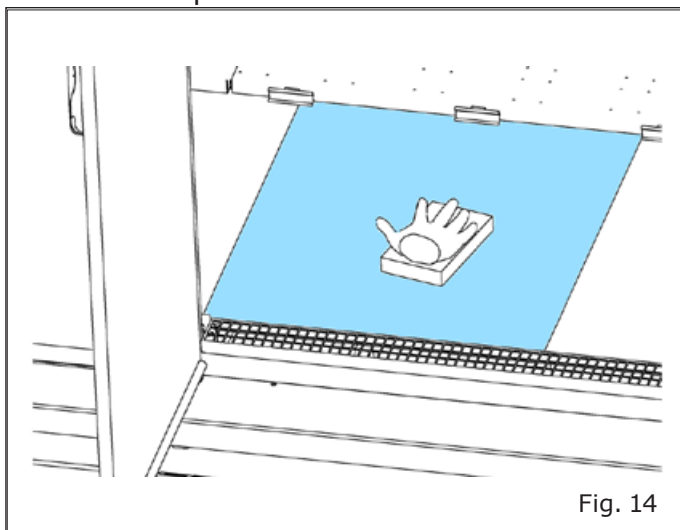

Fig. 14



Fare attenzione alle ventole dell'evaporatore! Non toccarle con le dita, stracci o altri utensili.

- Pulire il piano di fondo con sapone neutro o detergente in acqua tiepida. Controllare che lo scarico non sia ostruito.

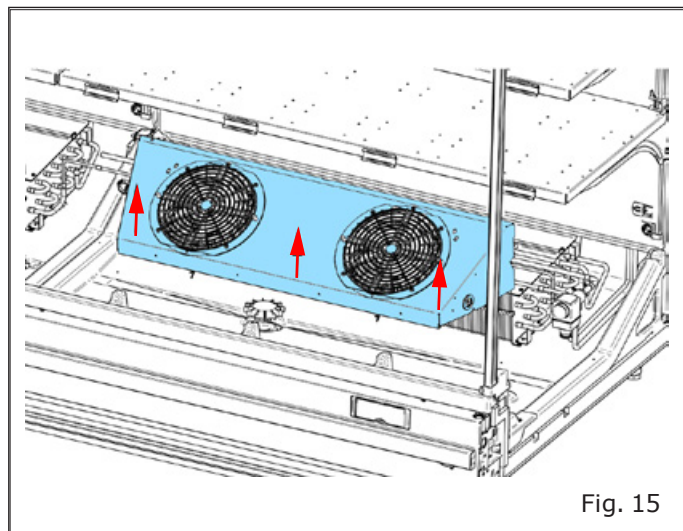

Fig. 15

- Pulire l'interno del condotto di scarico utilizzando un aspiraliquidi per rimuovere eventuali particelle.

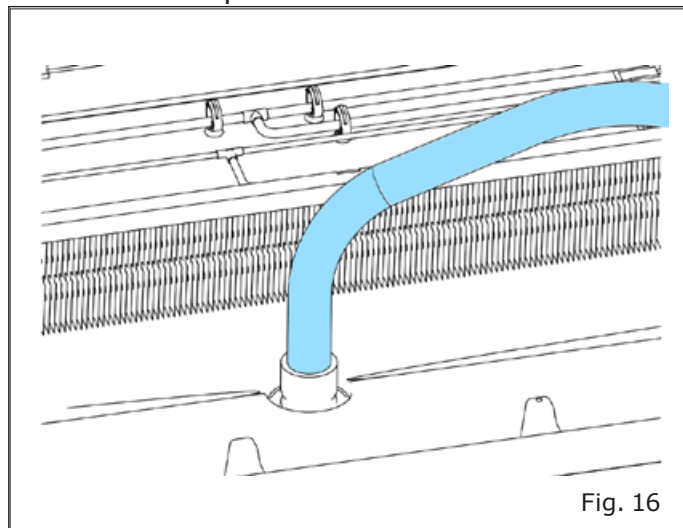
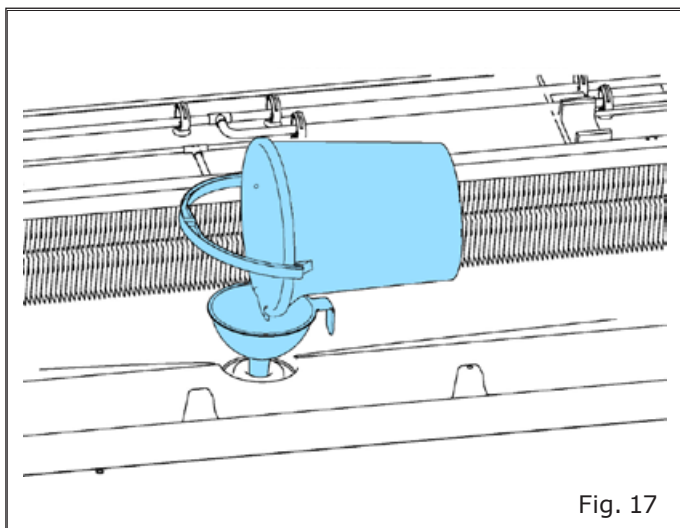

Fig. 16

Modello - Modèle - Model Modell - Modelo - Modelo	GRANVISTA INTEGRAL AIR	COSTAN eptarefrigeration
Fabbricante - Constructeur - Manufacturer Hersteller - Fabricante - Fabricante	Epta Spa - Via Mecenate, 86 - 20138 Milano (MI) ITALIA Tel. 02/55403211 Telefax 02/55401023	9/10

- Risciacquare il condotto di scarico con acqua.



- Pulire completamente l'apertura dello scarico e risciacquare con acqua corrente.

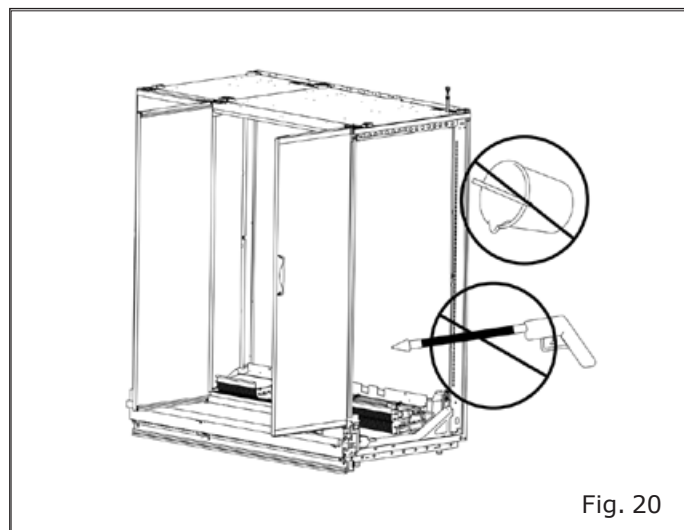
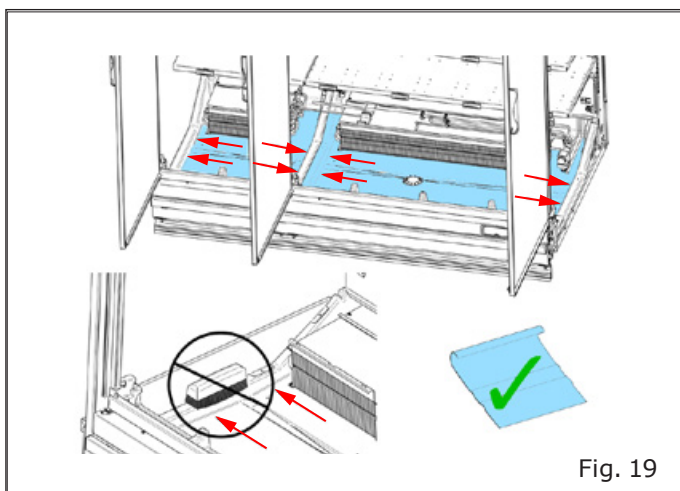
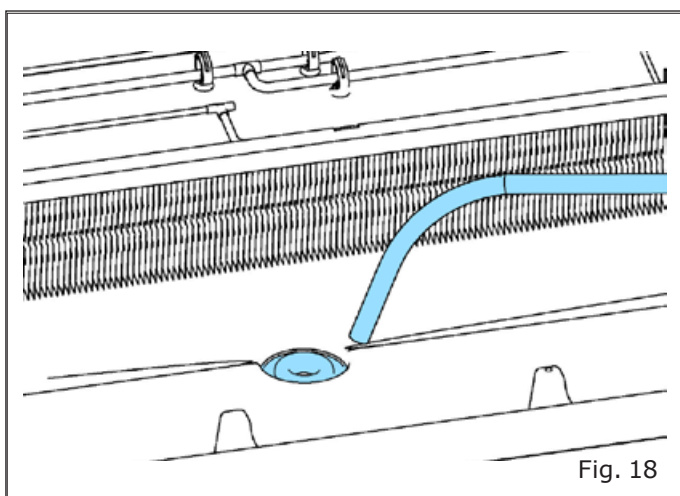

3.4 Pulizia del condensatore

- Se il condensatore è sporco a causa di polvere, il calore non può essere smaltito come previsto e il banco non funziona correttamente. È perciò necessario eseguire regolarmente l'ispezione e la pulizia.
- In caso di configurazione back to back, utilizzare una scala e rimuovere la griglia di protezione tra i due banchi.

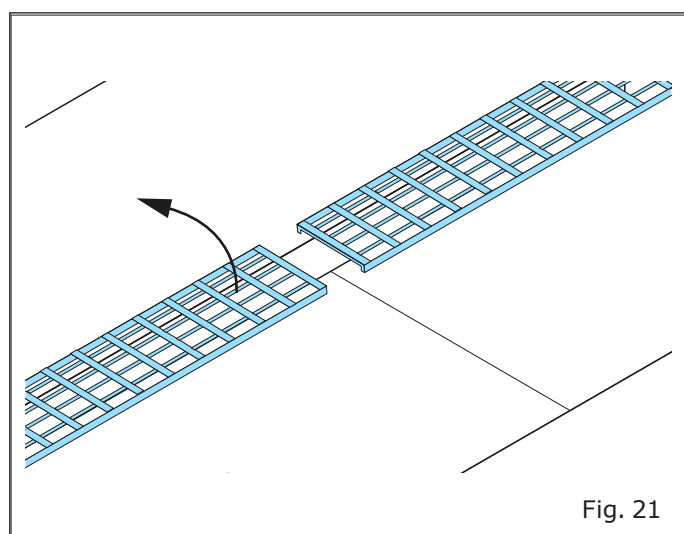

IT

FR

EN

DE

ES

PT

Modello - Modèle - Model Modell - Modelo - Modelo	GRANVISTA INTEGRAL AIR	COSTAN eptarefrigeration
Fabbricante - Constructeur - Manufacturer Hersteller - Fabricante - Fabricante	Epta Spa - Via Mecenate, 86 - 20138 Milano (MI) ITALIA Tel. 02/55403211 Telefax 02/55401023	10/10

Cleaning instruction

IT

FR

EN

DE

ES

PT

- Pulire il condensatore con un aspiratore industriale o con una spazzola.

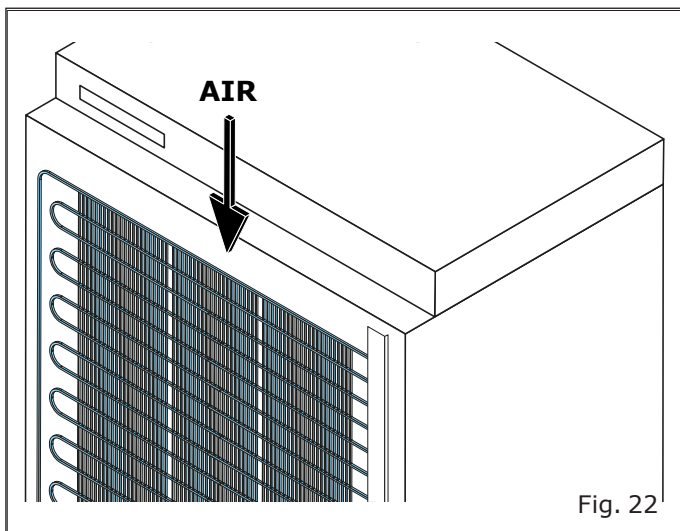

- Successivamente, reinstallare la protezione del condensatore.
- Rimuovere i deflettori della ventola.

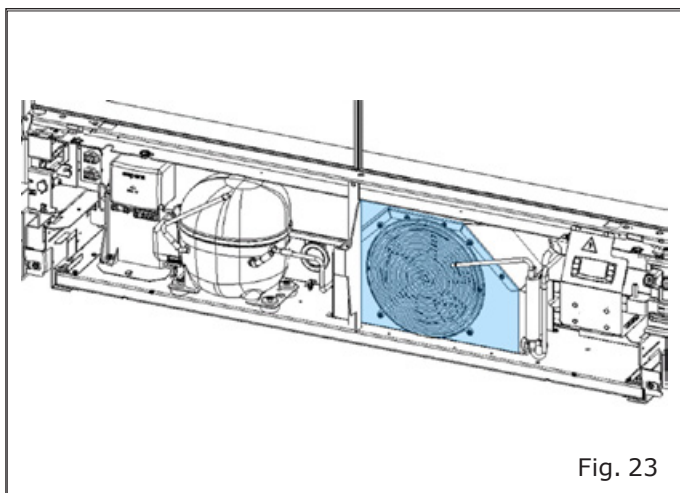

- Pulizia della bacinella di dissipazione dell'acqua

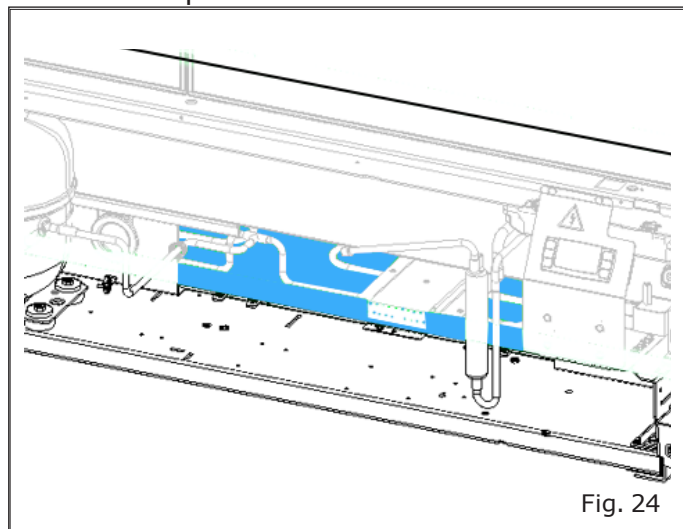

3.5 Assemblaggio del banco

Seguire le fasi di disassemblaggio in ordine inverso:

- Reinstallare la struttura interna e i ripiani.
- Assicurarsi che le staffe di supporto dei ripiani siano nella posizione corretta e completamente bloccate nei loro supporti durante la reinstallazione.
- Reinstallare il piano di fondo.
- Reinstallare la griglia di ripresa d'aria.

3.6 Riaccensione del banco

- Dopo aver completato la pulizia e verificato attentamente che l'interno del banco sia completamente asciutto, rimettere in funzione il banco ripristinando l'alimentazione.
- Il banco inizierà il ciclo di raffreddamento. Far raggiungere una temperatura di -3°C prima di ricaricare la merce.

Modello - Modèle - Model Modell - Modelo - Modelo	GRANVISTA INTEGRAL AIR	COSTAN eptarefrigeration
Fabbricante - Constructeur - Manufacturer Hersteller - Fabricante - Fabricante	Epta Spa - Via Mecenate, 86 - 20138 Milano (MI) ITALIA Tel. 02/55403211 Telefax 02/55401023	2/10

Cleaning instruction

TABLE DES MATIÈRES

IT

FR

EN

DE

ES

PT

1. Introduction	2
1.1 Périmètre	2
1.2 Informations générales de Sécurité	2
1.3 Pourquoi nettoyer	2
2. Produits de nettoyage	3
3. Nettoyage du meuble	4
3.1 Nettoyage des parties extérieures du meuble frigorifique de vente	4
3.2 Nettoyage de l'intérieur du meuble frigorifique de vente	4
3.3 Nettoyage du bac de fond (cuve)	6
3.4 Nettoyage du condenseur	8
3.5 Assemblage des meubles	9
3.6 Redémarrage du meuble	9

SYMBOLIQUE UTILISÉE



Symbole d'interdiction: interdiction d'effectuer certaines opérations.



Symbole d'attention: normes anti-accident pour l'opérateur.



Symbole d'avertissement: risque d'endommager le meuble réfrigéré et/ou ses composants.



Symbole de remarque: fourniture d'informations utiles.

Équipement de protection individuelle

	Chaussures de sécurité
	Gants de protection
	Lunettes de protection
	Casque de sécurité
	Gilet réfléchissant

Modello - Modèle - Model Modell - Modelo - Modelo	GRANVISTA INTEGRAL AIR	COSTAN eptarefrigeration
Fabbricante - Constructeur - Manufacturer Hersteller - Fabricante - Fabricante	Epta Spa - Via Mecenate, 86 - 20138 Milano (MI) ITALIA Tel. 02/55403211 Telefax 02/55401023	3/10

1. INTRODUCTION

1.1 Périmètre

Le document « Cleaning instruction » indique comment nettoyer un meuble frigorifique de vente pour aliments.

Il contient également des informations sur la manière de protéger la sécurité des personnes chargées du nettoyage.

Ces instructions sont aussi disponibles sur : www.eptarefrigeration.com.

1.2 Informations générales de Sécurité



Ne jamais interrompre la chaîne du froid des denrées exposées !



Avant d'entreprendre toute opération d'entretien ou de nettoyage, débrancher l'appareil de l'alimentation électrique et le protéger contre tout branchement par des personnes non autorisées.



S'assurer que la zone de travail est suffisamment éclairée pendant les activités de maintenance et de nettoyage et utiliser une source d'éclairage supplémentaire si nécessaire.



Les portes et les parois vitrées sont pourvues d'un film intérieur antibuée. Ne pas utiliser de détergent contenant des substances abrasives, fortement acides ou caustiques.



Attention à ne pas toucher les pièces en rotation du meuble (ventilateurs) avec les doigts, des serviettes ou d'autres outils.



Ne pas retirer les protections ni les couvercles.

1.3 Pourquoi nettoyer

Afin de présenter les produits et denrées de façon attrayante et hygiénique, il est important de nettoyer régulièrement le meuble réfrigéré. Un nettoyage régulier empêche également les moisissures et les bactéries nocives de s'installer dans le meuble, car la poussière humide constitue un terrain de reproduction idéal.

Un nettoyage régulier est également essentiel pour le bon fonctionnement technique. C'est le seul moyen de garantir un échange thermique optimal et une bonne circulation de l'air dans le meuble.

IT

FR

EN

DE

ES

PT

Modello - Modèle - Model Modell - Modelo - Modelo	GRANVISTA INTEGRAL AIR	COSTAN  eptarefrigeration
Fabbricante - Constructeur - Manufacturer Hersteller - Fabricante - Fabricante	Epta Spa - Via Mecenate, 86 - 20138 Milano (MI) ITALIA Tel. 02/55403211 Telefax 02/55401023	4/10

Cleaning instruction

IT

2. PRODUITS DE NETTOYAGE

FR

Vêtements de travail

- Gants de protection
- Vêtements de protection
- Lunettes de protection

EN

DE

ES

Produits de nettoyage pour surfaces autres que vitrées

PT

- Eau
- Détergent doux
- Éponges, chiffons et chiffons doux, non abrasifs

Produits de nettoyage pour surfaces vitrées

- Eau
- Détergent doux
- Nettoyant à vitres standard
- Détachants pour taches d'huile
- Éponges, chiffons et serviettes en papier, non abrasifs.

Ne pas utiliser ce qui suit

- Produits de nettoyage fortement corrosifs
- Produits de nettoyage acides ou caustiques
- Produits inflammables
- Acétone
- Produits de nettoyage contenant des solvants
- Nettoyants abrasifs
- Nettoyant haute pression ou autre jet d'eau puissant pour nettoyer

Modello - Modèle - Model Modell - Modelo - Modelo	GRANVISTA INTEGRAL AIR	COSTAN eptarefrigeration
Fabbricante - Constructeur - Manufacturer Hersteller - Fabricante - Fabricante	Epta Spa - Via Mecenate, 86 - 20138 Milano (MI) ITALIA Tel. 02/55403211 Telefax 02/55401023	5/10

3. NETTOYAGE DU MEUBLE

3.1 Nettoyage des parties extérieures du meuble frigorifique de vente

- Nettoyer les surfaces extérieures de la vitrine avec un savon doux ou un détergent dans de l'eau tiède uniquement.
- Essuyer soigneusement avec des éponges, des chiffons et des chiffons doux, non abrasifs.

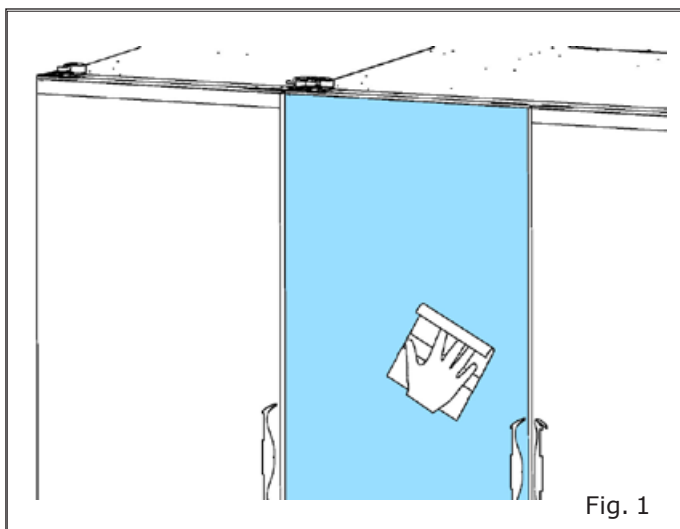

3.2 Nettoyage de l'intérieur du meuble frigorifique de vente

- Retirez les marchandises exposées et rangez-les dans des réfrigérateurs ou des chambres froides.
- Ne pas interrompre la chaîne du froid.
- Débrancher l'appareil de l'alimentation électrique et le protéger contre tout branchement par des personnes non autorisées.

Nettoyage des portes et joues vitrées :

- Les nettoyer en utilisant un nettoyant pour vitres standard avec une éponge non abrasive, un chiffon ou une serviette en papier.

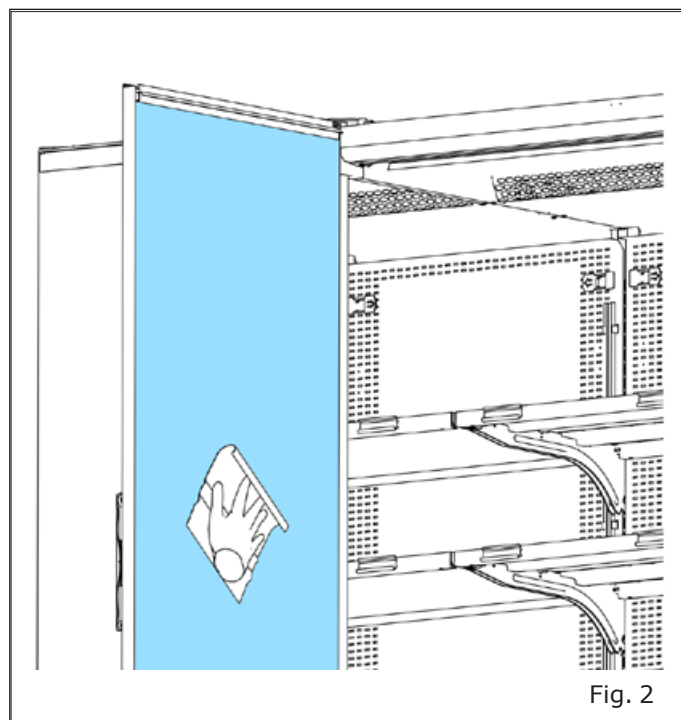

Les résidus graisseux doivent être éliminés à l'aide d'un détachant pour huile.

Nettoyage des étagères :

- Les surfaces peuvent être nettoyées avec un savon doux ou un détergent dans de l'eau tiède.

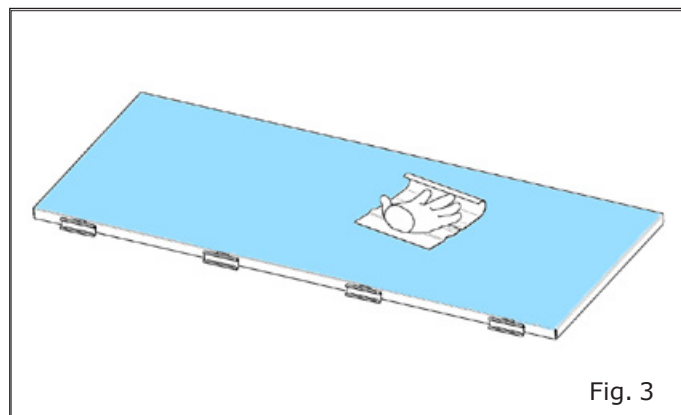

Cleaning instruction

- Pour faciliter le nettoyage, il est possible de détacher et retirer les étagères de la crémaillère.

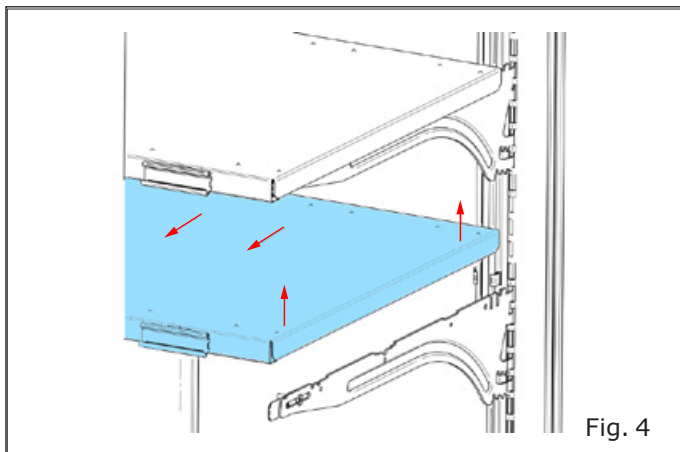

Veillez faire pivoter l'étagère pour l'extraire de l'appareil.

- S'assurer que les bras d'étagères sont dans la bonne position et qu'ils se verrouillent complètement dans la crémaillère lorsqu'ils sont à nouveau fixés.

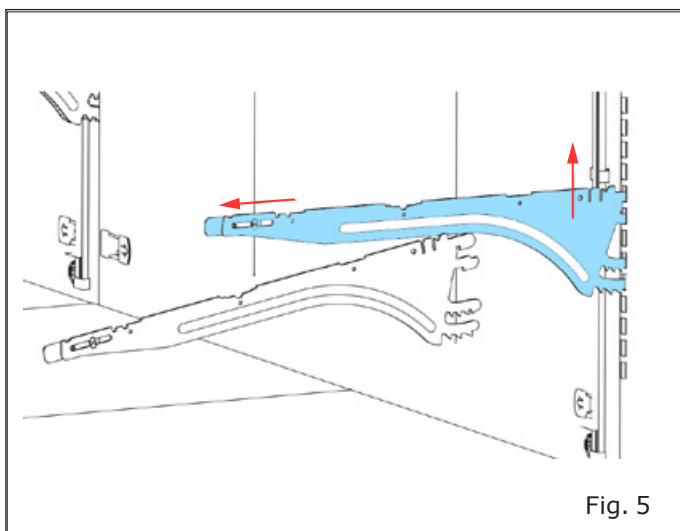

Démontage de la structure interne

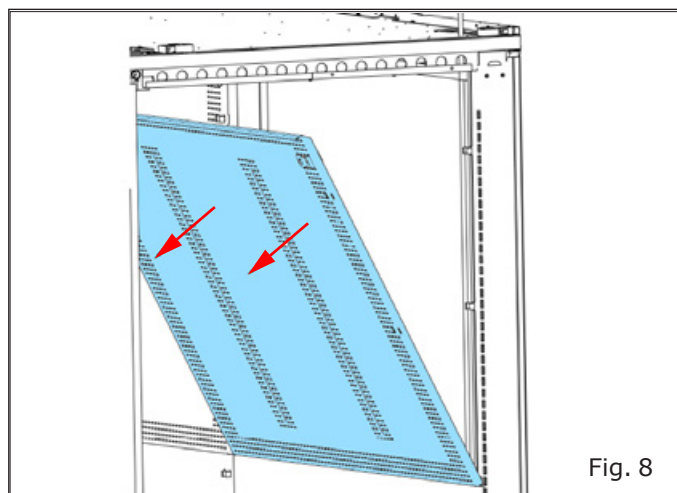
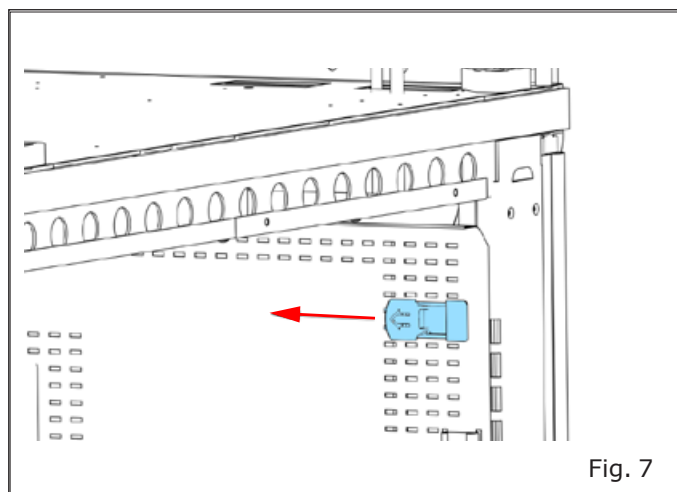
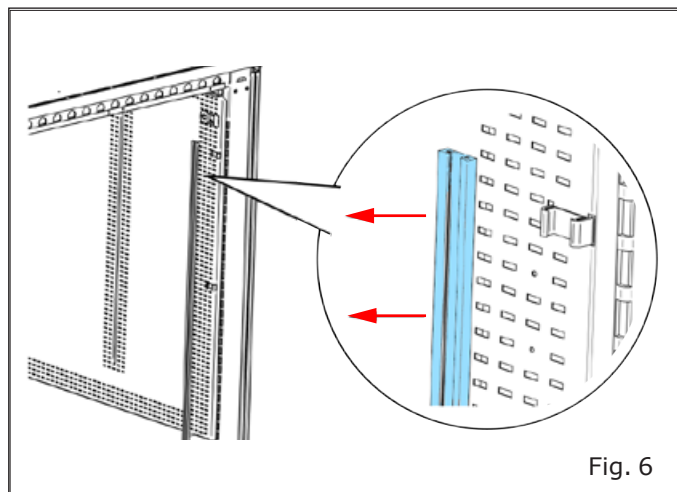

Modello - Modèle - Model Modell - Modelo - Modelo	GRANVISTA INTEGRAL AIR	COSTAN eptarefrigeration
Fabbricante - Constructeur - Manufacturer Hersteller - Fabricante - Fabricante	Epta Spa - Via Mecenate, 86 - 20138 Milano (MI) ITALIA Tel. 02/55403211 Telefax 02/55401023	7/10

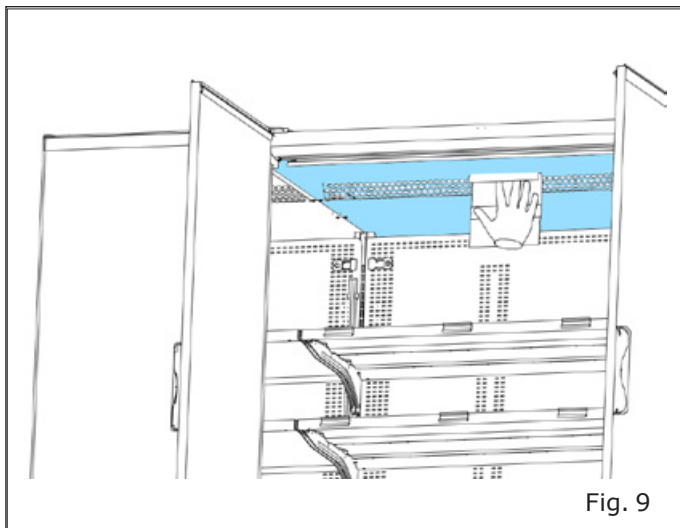

Fig. 9

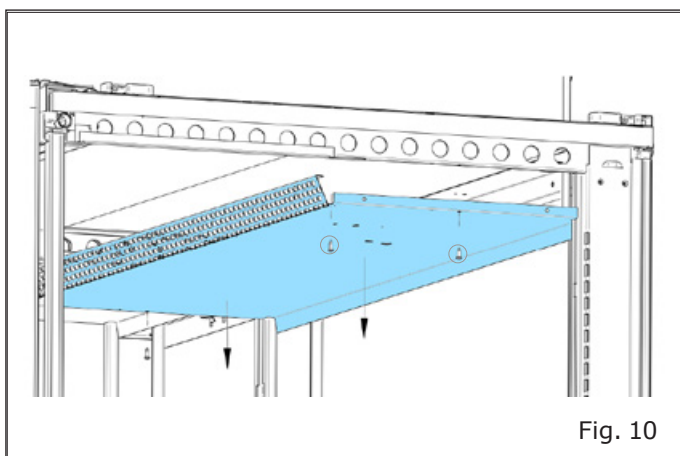

Fig. 10

3.3 Nettoyage du bac de fond (cuve)



Le nettoyage du bac de fond ne doit être effectué que par du personnel qualifié.

- Ne pas interrompre la chaîne du froid.
- Débrancher l'appareil de l'alimentation électrique et le protéger contre tout branchement par des personnes non autorisées.
- Retirer les grilles de reprise d'air et les nettoyer à l'aide d'un chiffon humide.

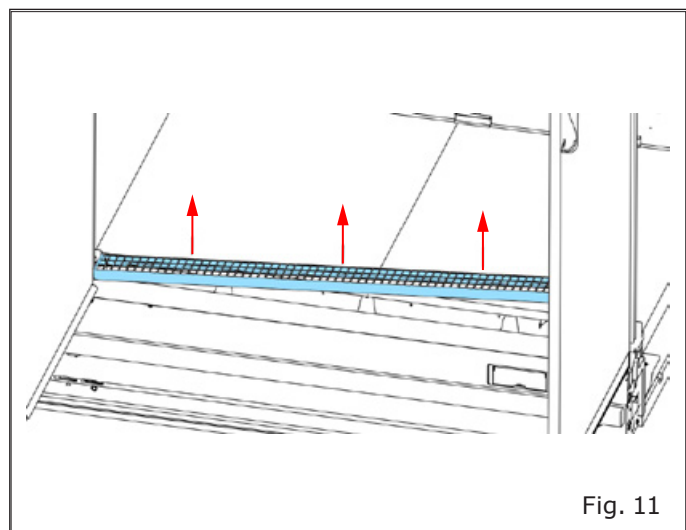

Fig. 11

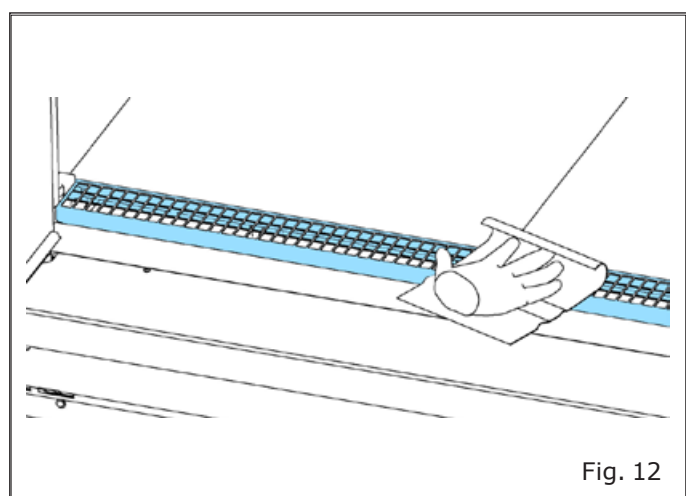
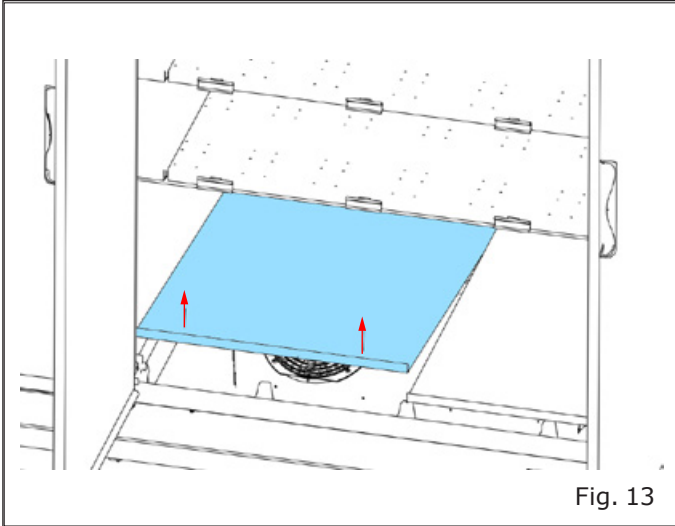

Fig. 12

Cleaning instruction

- Retirer le plateau de cuve.



- Le nettoyer à l'aide d'un chiffon humide.

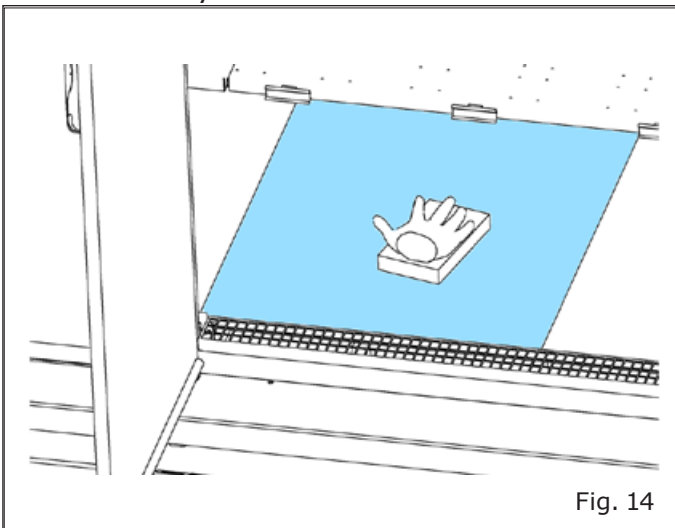

ATTENTION AUX VENTILATEURS D'EVAPORATEURS EN ROTATION ! NE LES TOUCHEZ PAS AVEC LES DOIGTS, CHIFFONS OU D'AUTRES OUTILS !

- Nettoyer le bac de fond avec un savon ou un détergent doux dans de l'eau tiède. Vérifier que le siphon n'est pas bouché.

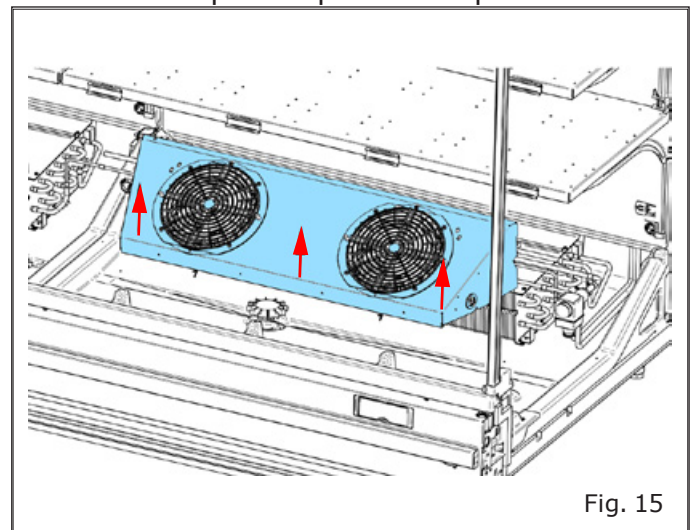

- Nettoyer l'intérieur du siphon à l'aide d'un aspirateur humide pour éliminer toutes les particules

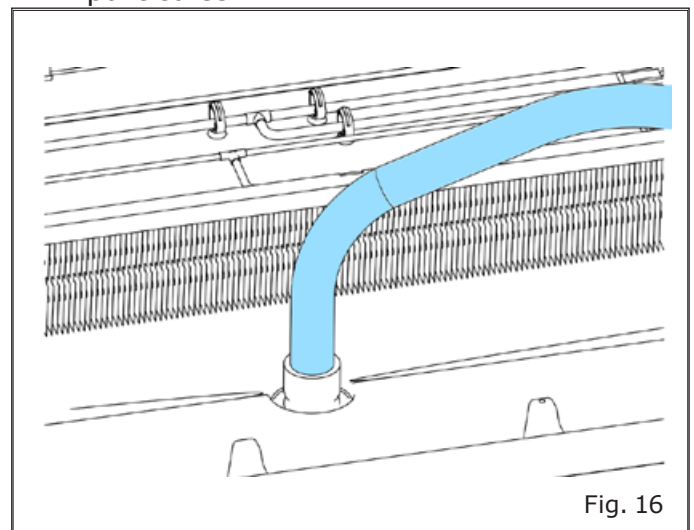

Modello - Modèle - Model Modell - Modelo - Modelo	GRANVISTA INTEGRAL AIR	COSTAN eptarefrigeration
Fabbricante - Constructeur - Manufacturer Hersteller - Fabricante - Fabricante	Epta Spa - Via Mecenate, 86 - 20138 Milano (MI) ITALIA Tel. 02/55403211 Telefax 02/55401023	9/10

- Rincer le siphon avec de l'eau

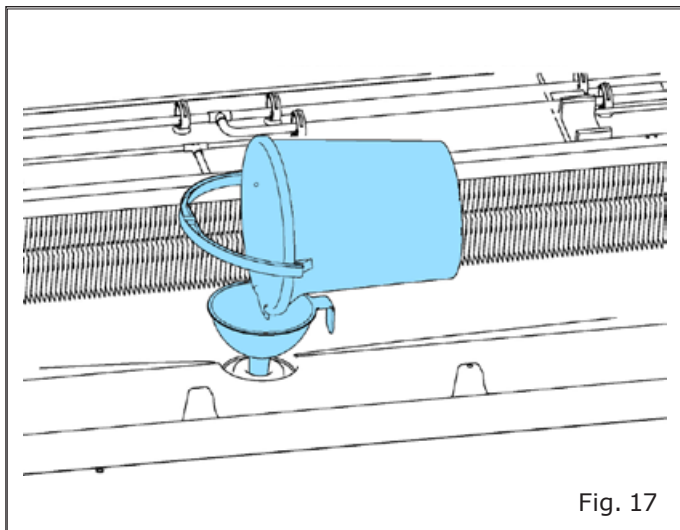

- Nettoyer entièrement la bonde de vidange et la rincer à l'eau courante.

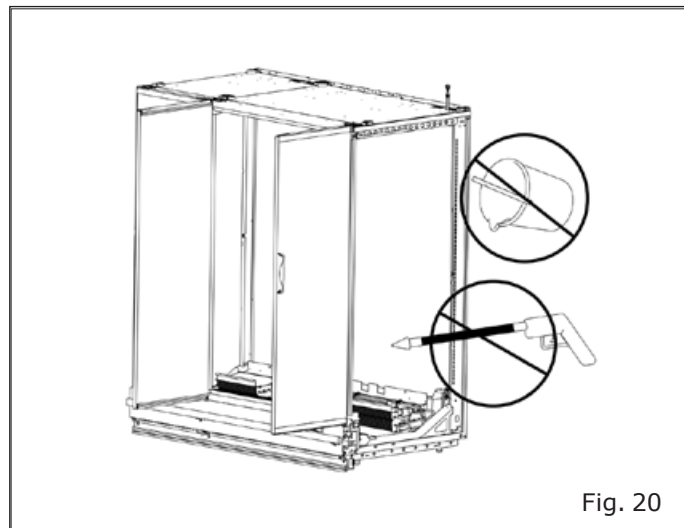
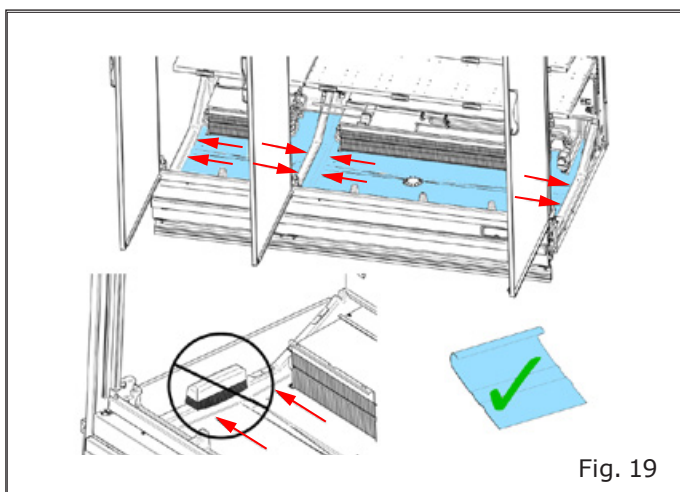
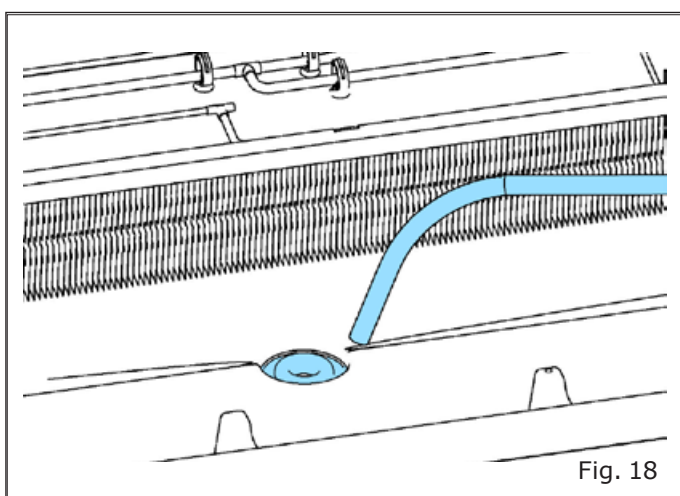

3.4 Nettoyage du condenseur

- Si le condenseur est encrassé par la poussière, la chaleur ne peut plus être dissipée et le meuble frigorifique de vente peut tomber en panne. Une inspection et un nettoyage réguliers sont donc nécessaires.
- Dans le cas d'une configuration dos à dos, à l'aide d'un escalier, enlever par le haut le cache du condenseur situé entre les deux meubles.

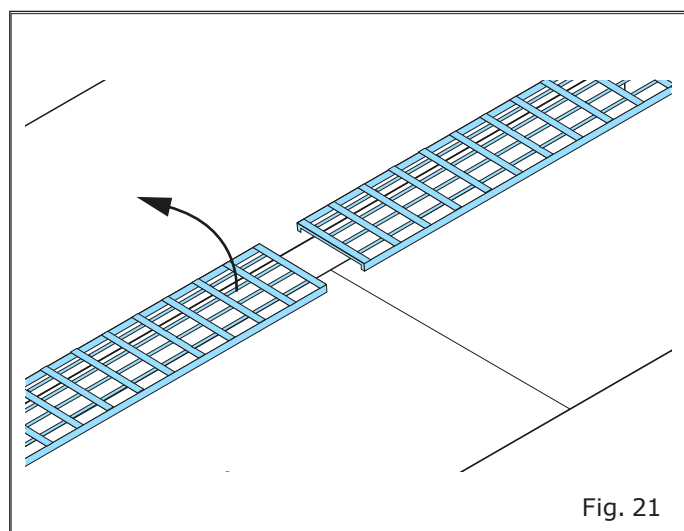

Modello - Modèle - Model Modell - Modelo - Modelo	GRANVISTA INTEGRAL AIR	COSTAN eptarefrigeration
Fabbricante - Constructeur - Manufacturer Hersteller - Fabricante - Fabricante	Epta Spa - Via Mecenate, 86 - 20138 Milano (MI) ITALIA Tel. 02/55403211 Telefax 02/55401023	10/10

Cleaning instruction

IT
FR
EN
DE
ES
PT

- Nettoyer le condenseur avec un aspirateur industriel ou une brosse à main.

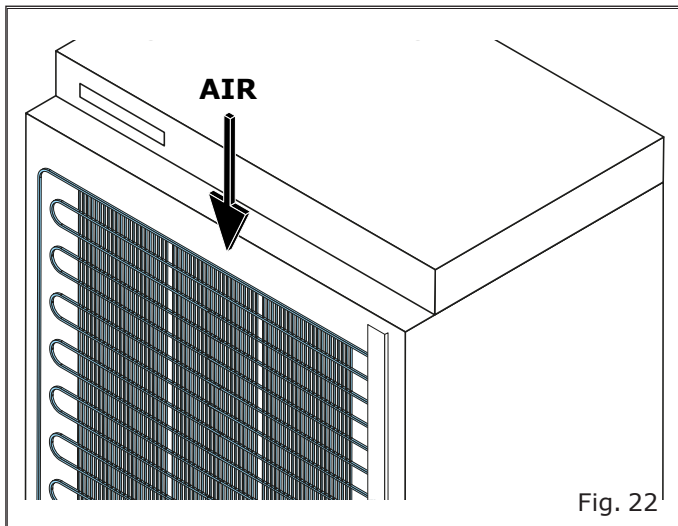

- Puis, réinstaller le cache condenseur.
- Retirer le déflecteur du ventilateur

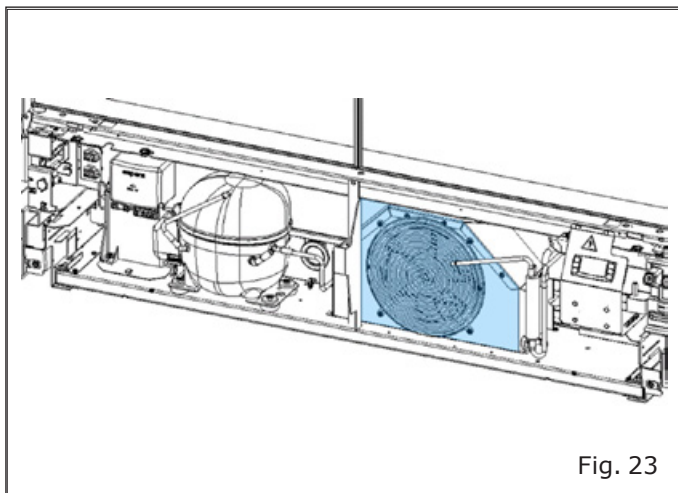

- Nettoyage du bac de récupération eaux de condensat

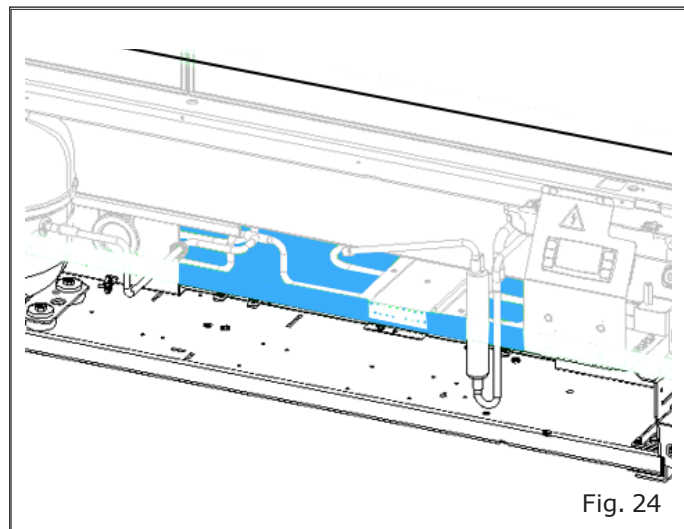

3.5 Assemblage des meubles

Suivre les mêmes phases que celles du démontage dans l'ordre inverse :

- Réinstaller la structure interne et les étagères.
- S'assurer que les bras d'étagères sont dans la bonne position et qu'ils se verrouillent complètement dans la crémaillère lorsqu'ils sont à nouveau fixés.
- Réinstaller le plateau de cuve.
- Réinstaller les grilles de reprise.

3.6 Redémarrage du meuble

- Après avoir terminé le nettoyage et vérifié attentivement que l'intérieur du meuble est complètement sec, remettre l'appareil en service en rebranchant l'alimentation électrique du meuble.
- Le meuble commencera alors son cycle de refroidissement. Laisser les meubles atteindre une température affichée de -3°C avant de recharger les denrées/ produits retirés.

Modello - Modèle - Model Modell - Modelo - Modelo	GRANVISTA INTEGRAL AIR	COSTAN eptarefrigeration
Fabbricante - Constructeur - Manufacturer Hersteller - Fabricante - Fabricante	Epta Spa - Via Mecenate, 86 - 20138 Milano (MI) ITALIA Tel. 02/55403211 Telefax 02/55401023	2/10

Cleaning instruction

IT

INDICE

FR

1. Introduction	2
1.1 Scope	2
1.2 General safety information	2
1.3 Reasons for cleaning	2
2. Cleaning agents	3
3. Cleaning the appliance	4
3.1 Cleaning of the refrigerated display cabinet exterior	4
3.2 Cleaning of the refrigerated display cabinet interior	4
3.3 Cleaning of the base deck	6
3.4 Cleaning of the condenser	8
3.5 Cabinet's assembly	9
3.6 Cabinet restart	9

EN

DE

ES

PT

SYMBOLS USED



Prohibition symbol: it prohibits the carrying out of specific operations.



Attention symbol: accident prevention rules for the operator.



Warning symbol: there is the possibility of damaging the cabinet and/or its components.



Note symbol: it provides useful information.

Personal protection equipment

	Safety shoes
	Protective gloves
	Safety glasses
	Safety helmet
	Safety vests

Modello - Modèle - Model Modell - Modelo - Modelo	GRANVISTA INTEGRAL AIR	COSTAN eptarefrigeration
Fabbricante - Constructeur - Manufacturer Hersteller - Fabricante - Fabricante	Epta Spa - Via Mecenate, 86 - 20138 Milano (MI) ITALIA Tel. 02/55403211 Telefax 02/55401023	3/10

1. INTRODUCTION

1.1 Scope

The document "Cleaning Instructions" indicates how to clean the vertical chilled cabinet. It also contains information how to protect the safety of the persons in charge of cleaning.

Instructions for use are also available on:
www.eptarefrigeration.com.

1.2 General safety information

 Do never interrupt the cooling chain of displayed goods.

 Before starting any maintenance or cleaning, disconnect the equipment from the electrical power supply and secure against re-connecting by unauthorized persons.

 Ensure that the working area is sufficiently illuminated during maintenance and cleaning activities and use an additional lighting source if necessary.

 Doors and glass walls are provided with an antifog liner film inside. Do not use any detergent containing abrasive, strongly acidic or caustic substances.

 Beware of touching any rotation part of the cabinet (fans) with fingers, towels or other tools.

 Do not remove any protective guards and covers.

1.3 Reasons for cleaning

In order to present goods attractively and hygienically, it is important to clean the freezer cabinet regularly. Regular cleaning also prevents mould and harmful bacteria from settling in the furniture, as damp dust provides an ideal breeding ground.

Regular cleaning is also essential for the technical function. This is the only way to ensure that an optimal heat exchange takes place and that air can flow easily in the cabinet.

IT

FR

EN

DE

ES

PT

Modello - Modèle - Model Modell - Modelo - Modelo	GRANVISTA INTEGRAL AIR	COSTAN  eptarefrigeration
Fabbricante - Constructeur - Manufacturer Hersteller - Fabricante - Fabricante	Epta Spa - Via Mecenate, 86 - 20138 Milano (MI) ITALIA Tel. 02/55403211 Telefax 02/55401023	4/10

Cleaning instruction

IT

2. CLEANING AGENTS

FR

Work clothes

- Protective gloves
- Protective clothing
- Safety glasses

EN

DE

ES

Cleaning agent for surfaces other than glass

PT

- Water
- Mild detergent
- Non-scratching sponges, rags and soft cloths

Cleaning agent for glass surfaces

- Water
- Mild detergent
- Standard glass cleaner
- Oil stain removers
- Non-scratching sponges, rags and paper towels

The following must not be used

- Strong corrosive cleaning agents
- Acidic or caustic cleaning agents
- Inflammable agents
- Acetone
- Solvent containing cleaning agents
- Abrasive cleaners
- Jet-wash cleaner or other strong water jet to clean

Modello - Modèle - Model Modell - Modelo - Modelo	GRANVISTA INTEGRAL AIR	COSTAN eptarefrigeration
Fabbricante - Constructeur - Manufacturer Hersteller - Fabricante - Fabricante	Epta Spa - Via Mecenate, 86 - 20138 Milano (MI) ITALIA Tel. 02/55403211 Telefax 02/55401023	5/10

3. CLEANING THE APPLIANCE

3.1 Cleaning of the refrigerated display cabinet exterior

- Clean the outer surfaces of the display case with mild soap or detergent in lukewarm water only.
- Wipe carefully with non-scratching sponges, rags and soft cloths.

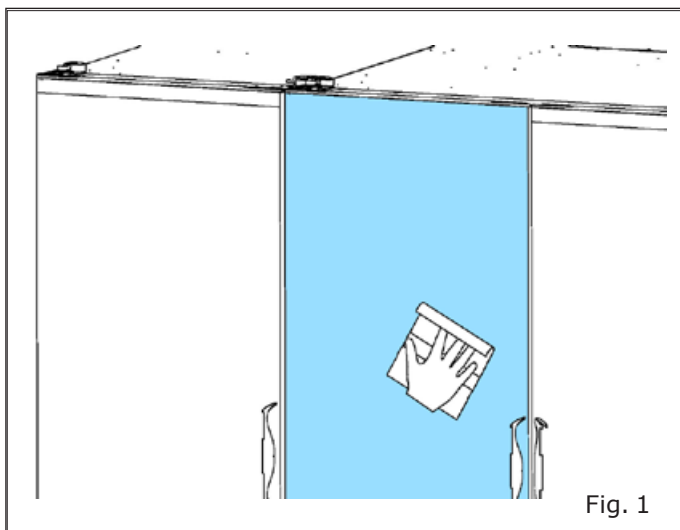

3.2 Cleaning of the refrigerated display cabinet interior

- Remove the displayed goods and store them into refrigerators or chilled rooms.
- Avoid interrupting the cooling chain.
- Disconnect the cabinet from the electrical power supply and secure against re-connecting by unauthorized persons.

Cleaning of the glass doors and glass walls inside:

- Clean it by using standard glass cleaner with a non-abrasive sponge, a rag or a paper towel.

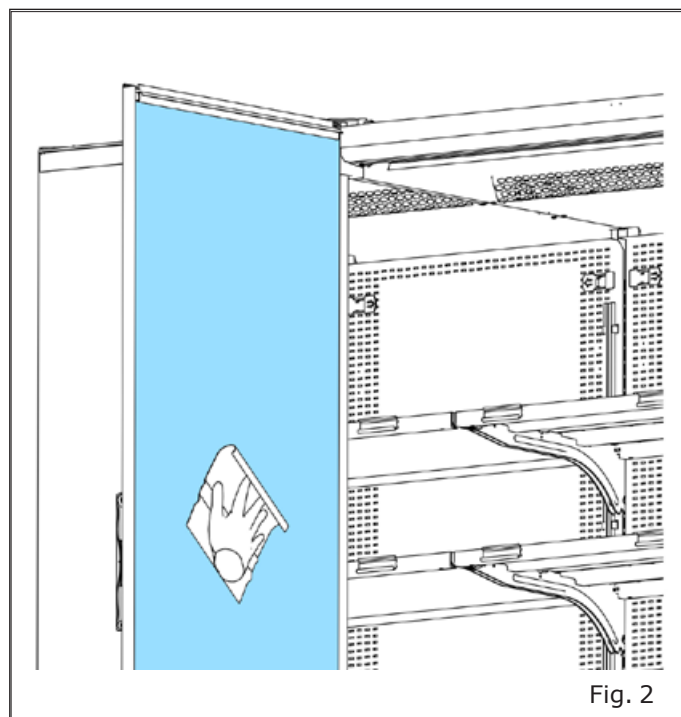

Greasy residue must be removed using oil stain remover.

Cleaning of the shelves:

- The surfaces can be cleaned with mild soap or detergent in lukewarm water.

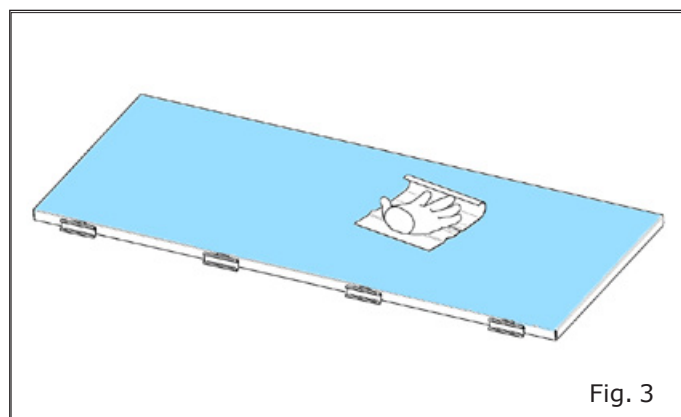

Cleaning instruction

- For convenient cleaning you can detach the shelves and take them off the rack.

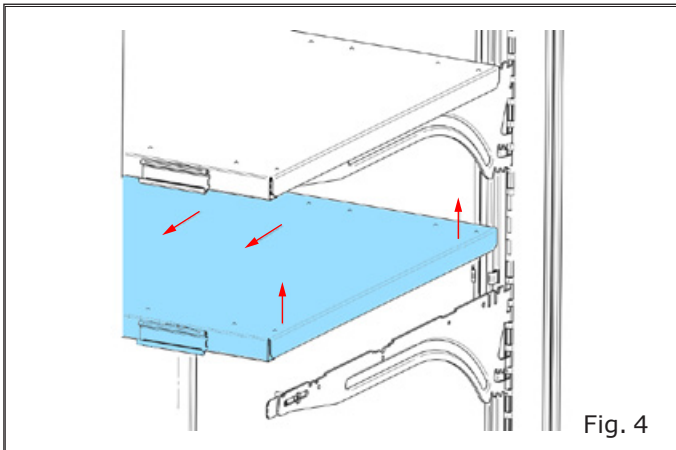

Please rotate the shelf to extract it from the cabinet.

- Make sure that the brackets are in the correct position and that the brackets lock completely into the support when you reattach them.

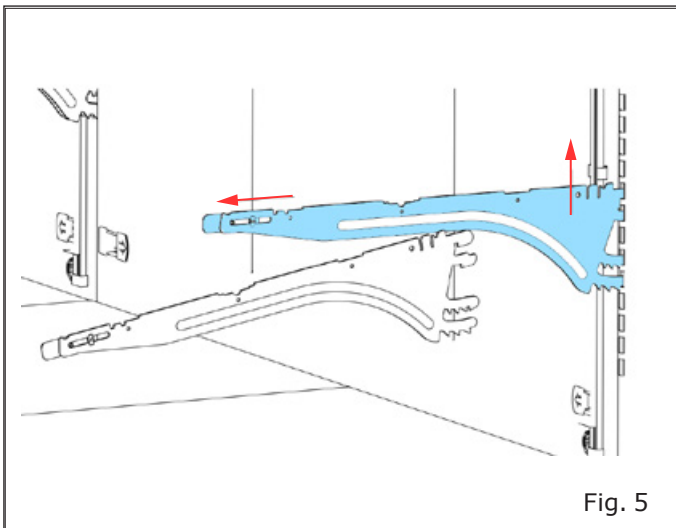

Removing of the internal structure

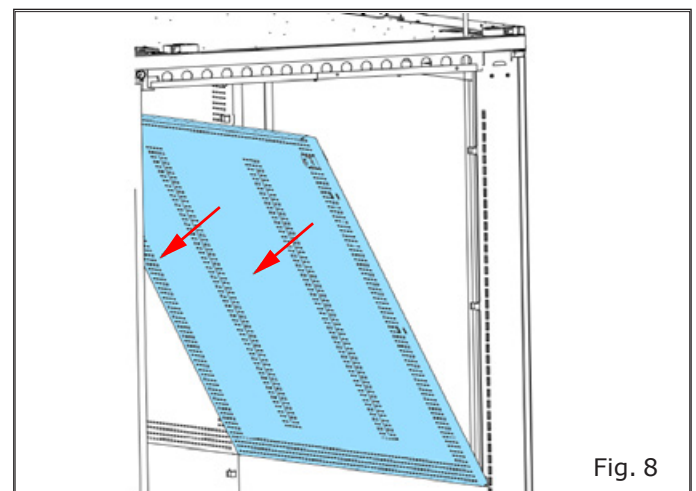
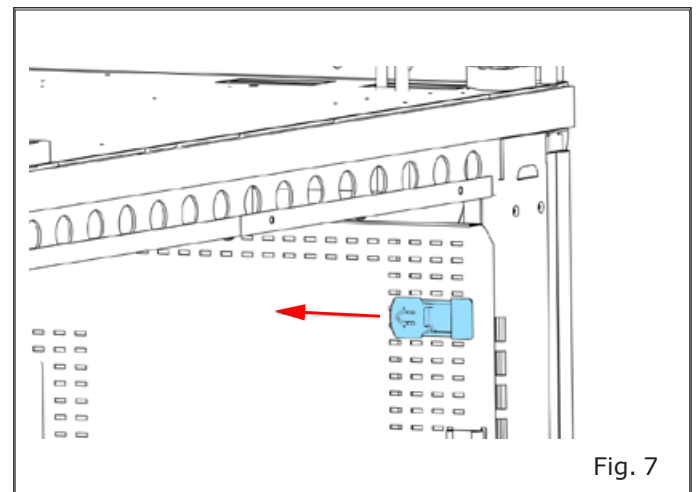
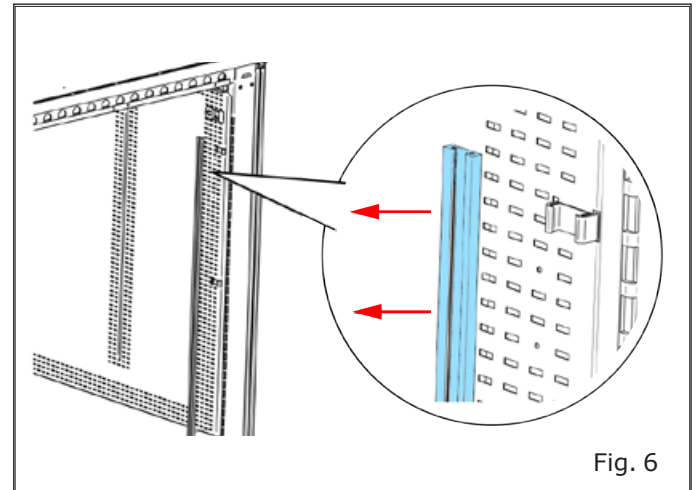

Modello - Modèle - Model Modell - Modelo - Modelo	GRANVISTA INTEGRAL AIR	COSTAN eptarefrigeration
Fabbricante - Constructeur - Manufacturer Hersteller - Fabricante - Fabricante	Epta Spa - Via Mecenate, 86 - 20138 Milano (MI) ITALIA Tel. 02/55403211 Telefax 02/55401023	7/10

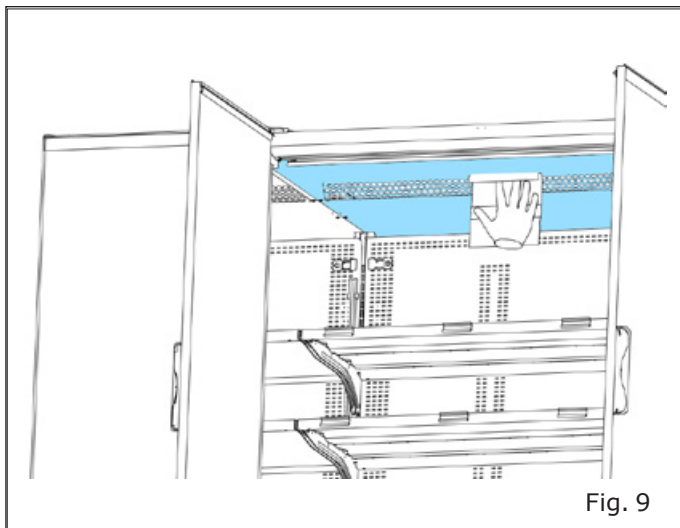

Fig. 9

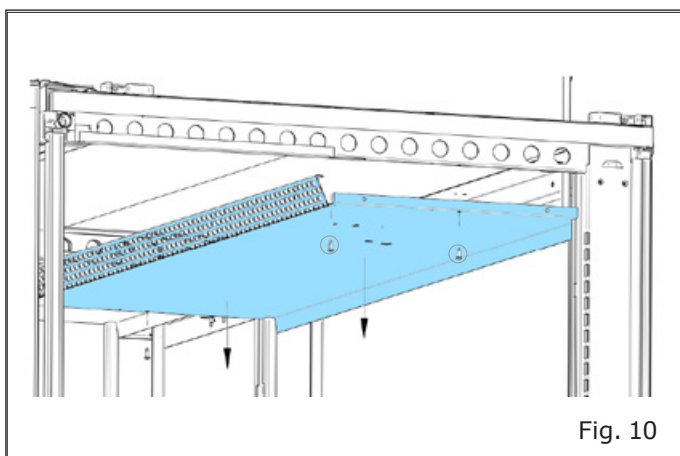

Fig. 10

3.3 Cleaning of the base deck



Cleaning of the base deck must be done by trained personnel only.

- Avoid interrupting the cooling chain.
- Disconnect the cabinet from the electrical power supply and secure against re-connecting by unauthorized persons.
- Remove the air-return grids and clean it by using a moist rag.

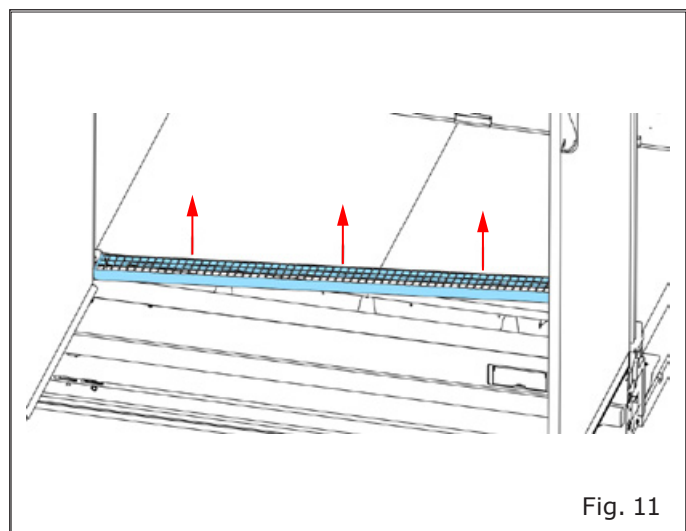

Fig. 11

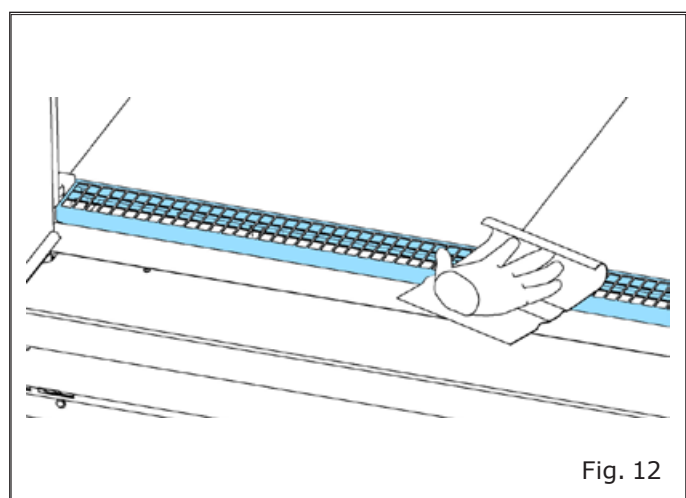
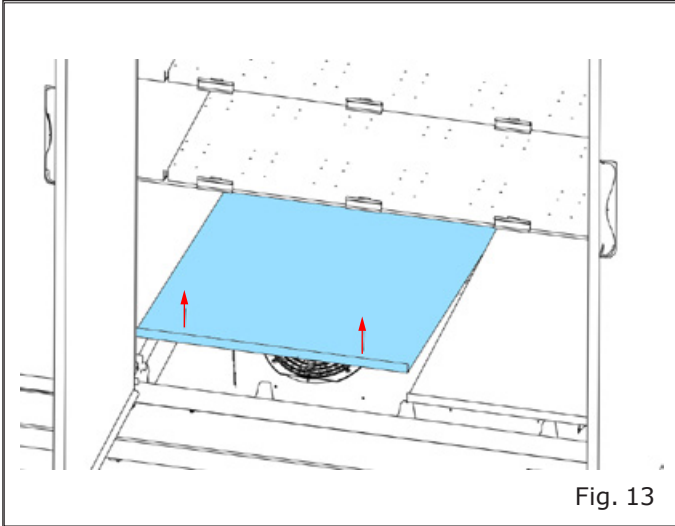

Fig. 12

Cleaning instruction

- Take off the base deck.



- Clean it by using a moist rag.

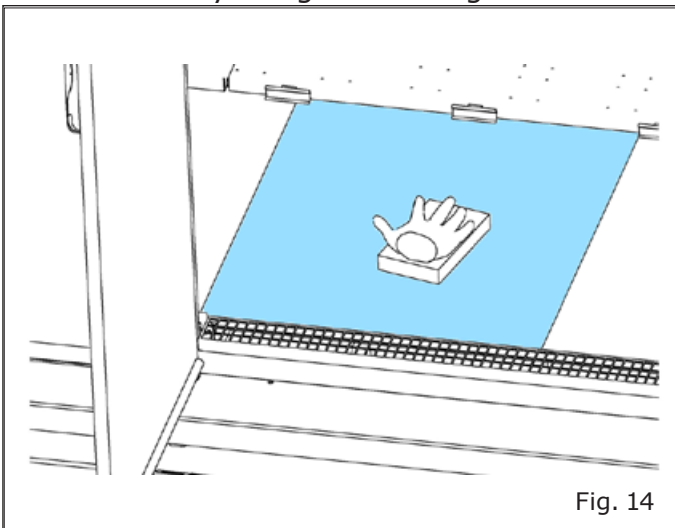

Be aware of rotating evaporator fans!
Do not touch them with finger, rags or other tools.

- Clean the base tray with mild soap or detergent in lukewarm water. Check that the drain is unclogged.

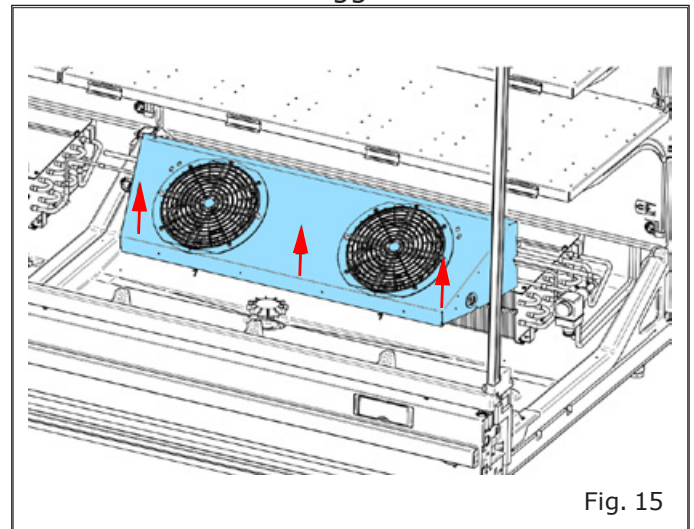

- Vacuum inside the drain using a wet vacuum cleaner to remove any particles.

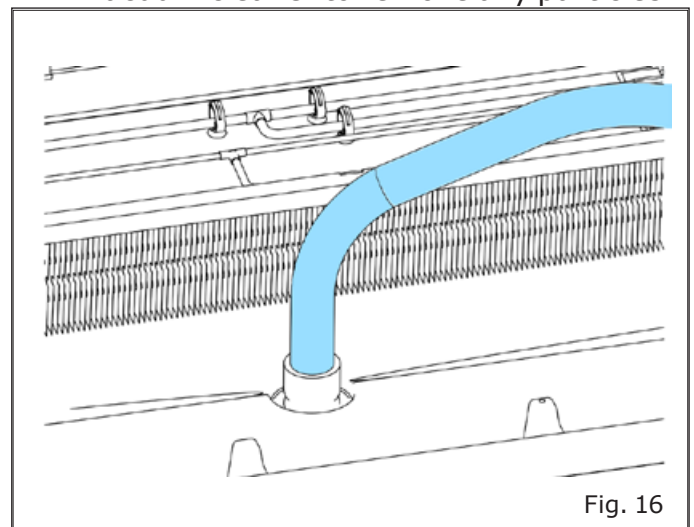

Modello - Modèle - Model Modell - Modelo - Modelo	GRANVISTA INTEGRAL AIR	COSTAN eptarefrigeration
Fabbricante - Constructeur - Manufacturer Hersteller - Fabricante - Fabricante	Epta Spa - Via Mecenate, 86 - 20138 Milano (MI) ITALIA Tel. 02/55403211 Telefax 02/55401023	9/10

- Rinse drain with water.

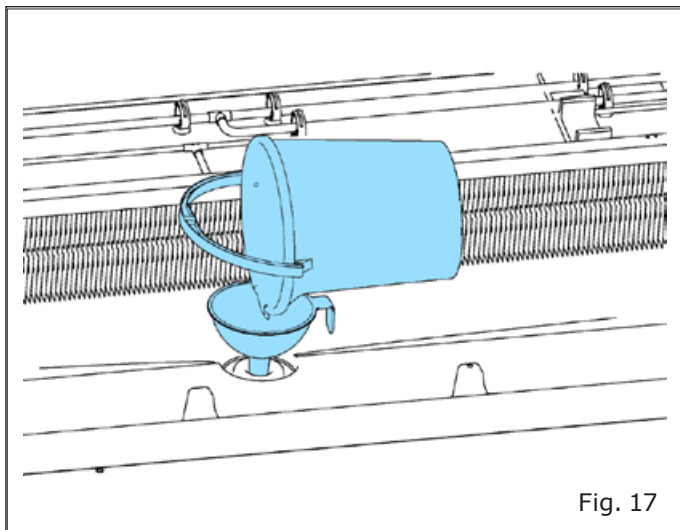

Fig. 17

- Clean the drainage opening entirely and rinse with running water.

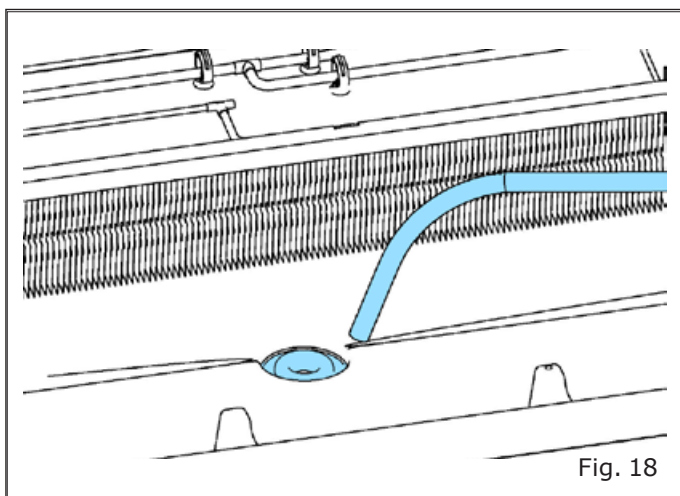

Fig. 18

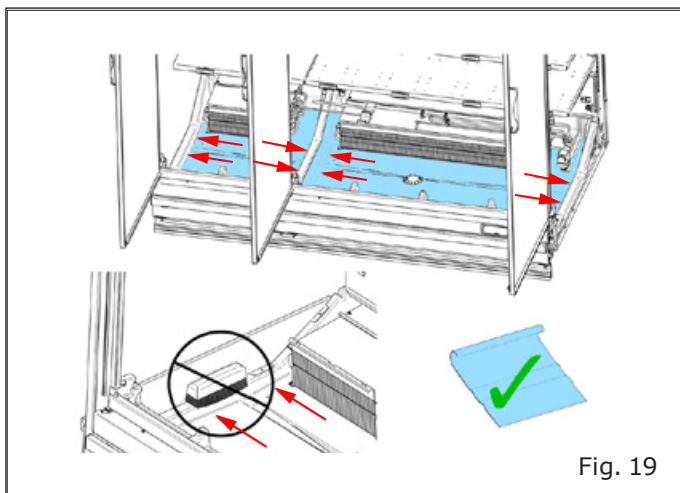

Fig. 19

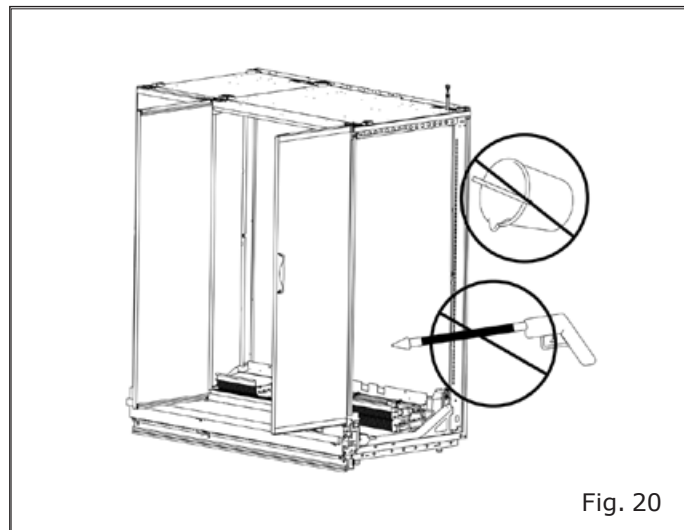

Fig. 20

3.4 Cleaning of the condenser

- If the condenser is soiled with dust, the heat can no longer be dissipated and the freezer cabinet may fail. Therefore regular inspection and cleaning is necessary.
- In case of a back to back configuration, with a staircase remove from the top the condenser mask between the two cabinets.

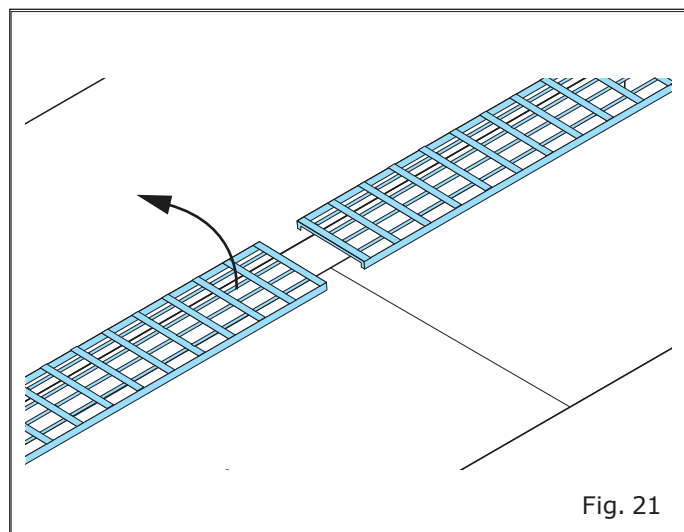

Fig. 21

Modello - Modèle - Model Modell - Modelo - Modelo	GRANVISTA INTEGRAL AIR	COSTAN eptarefrigeration
Fabbricante - Constructeur - Manufacturer Hersteller - Fabricante - Fabricante	Epta Spa - Via Mecenate, 86 - 20138 Milano (MI) ITALIA Tel. 02/55403211 Telefax 02/55401023	10/10

Cleaning instruction

IT
FR
EN
DE
ES
PT

- Clean the condenser with an industrial vacuum cleaner or a hand brush.

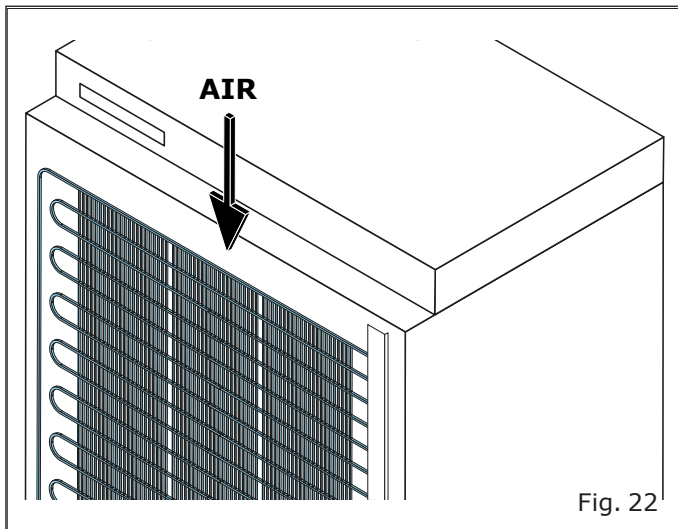

- Then reinstall the condenser mask.
- Remove the fan baffle.

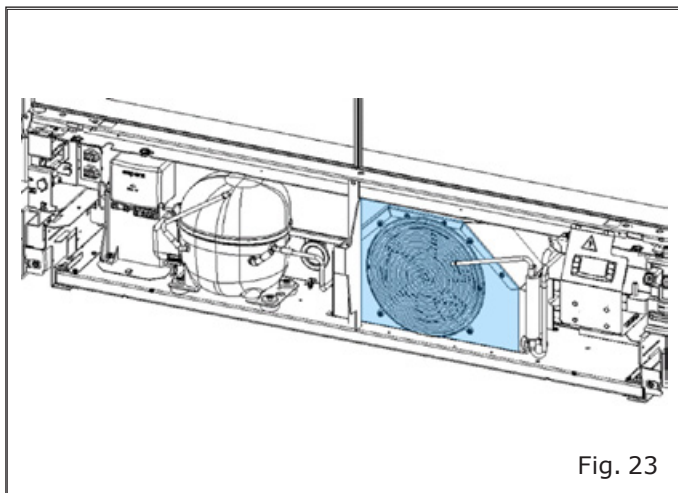

- Bowl cleaning

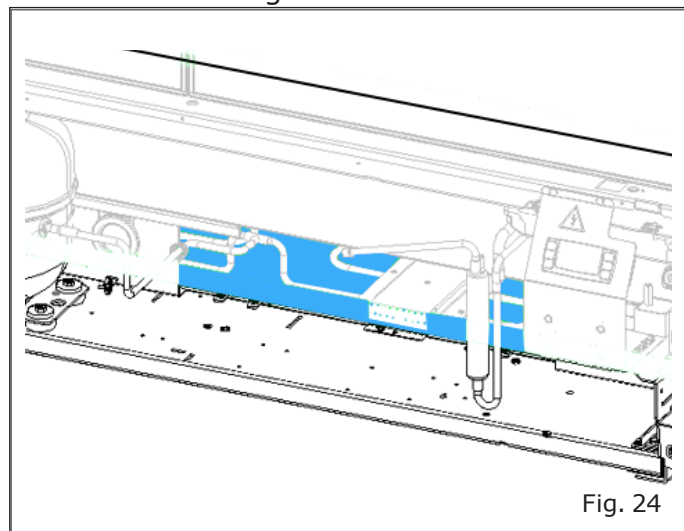

3.5 Cabinet's assembly

Follow the same disassembly phases in the reverse order:

- Reinstall the internal structure and the shelves.
- Make sure that the brackets are in the correct position and that the brackets lock completely into the support when you reattach them.
- Reinstall the base deck.
- Reinstall the air return grid.

3.6 Cabinet restart

- After completing the cleaning and attentively checking that the inside of the cabinet is completely dry, put the appliance back into operation by reconnecting power to the cabinet.
- The cabinet will then start its cooling cycle. Allow cabinets to reach a displayed temperature of -3°C before reloading the removed goods.

Modello - Modèle - Model Modell - Modelo - Modelo	GRANVISTA INTEGRAL AIR	COSTAN eptarefrigeration
Fabbricante - Constructeur - Manufacturer Hersteller - Fabricante - Fabricante	Epta Spa - Via Mecenate, 86 - 20138 Milano (MI) ITALIA Tel. 02/55403211 Telefax 02/55401023	2/10

Cleaning instruction

VERZEICHNIS

IT
FR
EN
DE
ES
PT

1. Einführung	2
1.1 Der Zweck dieses Dokuments	2
1.2 Allgemeine Sicherheitshinweise	2
1.3 Gründe für eine Reinigung	2
2. Reinigungsmittel	3
3. Reinigung der Kühlmöbel	4
3.1 Reinigung der Außenflächen der Kühlmöbel	4
3.2 Reinigung des Kühlmöbel-Innenraums	4
3.3 Reinigung der Auslagefläche	6
3.4 Reinigung des kondensators	8
3.5 Zusammensetzen des Kühlmöbels	9
3.6 Neustart des Kühlmöbels	9

VERWENDETE SYMBOLE



Symbol für ein Verbot: Verbieta bestimmte Handlungen.



Gefahrensymbol: Regeln zur Unfallvermeidung für den Benutzer.



Symbol für einen Warnhinweis: Möglicherweise kann ein Schaden am Gerät und/oder an einer der Komponenten entstehen.



Symbol für einen Hinweis: Es folgen nützliche Informationen.

Persönliche Schutzausrüstung

	Sicherheitsschuhe
	Schutzhandschuhe
	Schutzbrille
	Schutzhelm
	Sicherheitswesten

Modello - Modèle - Model Modell - Modelo - Modelo	GRANVISTA INTEGRAL AIR	COSTAN eptarefrigeration
Fabbricante - Constructeur - Manufacturer Hersteller - Fabricante - Fabricante	Epta Spa - Via Mecenate, 86 - 20138 Milano (MI) ITALIA Tel. 02/55403211 Telefax 02/55401023	3/10

1. EINFÜHRUNG

1.1 Der Zweck dieses Dokuments

Das Dokument "Cleaning instruction" enthält Informationen zur Reinigung des Kühlmöbels. Es enthält auch Informationen, wie die Sicherheit der mit der Reinigung beauftragten Personen gewährleistet werden kann.

Die Bedienungsanleitung ist auch unter verfügbar:
www.eptarefrigeration.com.

1.2 Allgemeine Sicherheitshinweise

 Die Kühlkette der gekühlten Waren darf keinesfalls unterbrochen werden.

 Trennen Sie das Gerät vom Stromnetz, bevor Sie Wartungs- oder Reinigungsarbeiten durchführen und stellen Sie sicher, dass die Stromzufuhr keinesfalls durch unbefugte Personen wieder eingeschaltet wird.

 Stellen Sie sicher, dass der Arbeitsbereich während der Wartungs- und Reinigungsarbeiten ausreichend beleuchtet ist, und schalten Sie, falls erforderlich, eine zusätzliche Lichtquelle ein.

 Die Türen und Glaswände sind von innen mit einer Antibeschlagfolie ausgerüstet. Verwenden Sie keine Scheuermittel oder Reinigungsmittel, die stark säurehaltige oder ätzende Substanzen enthalten.

 Achten Sie darauf, mit den Fingern, Handtüchern oder anderen Werkzeugen keine rotierenden Geräteteile (Lüfter) zu berühren.

 Entfernen Sie keine Schutzvorrichtungen oder Abdeckungen.

1.3 Gründe für eine Reinigung

Damit die Waren auf attraktive und hygienische Weise präsentiert werden, ist eine regelmäßige Reinigung des Kühlmöbels unverzichtbar. Eine regelmäßige Reinigung verhindert außerdem, dass sich Schimmel und schädliche Bakterien auf den Oberflächen ansiedeln, denn für sie bietet feuchter Staub einen idealen Nährboden.

Auch für den reibungslosen Betrieb der technischen Komponenten ist eine regelmäßige Reinigung entscheidend, denn nur dann ist gewährleistet, dass ein optimaler Wärmeaustausch stattfindet und die Luft im Kühlmöbel ungehindert zirkulieren kann.

IT

FR

EN

DE

ES

PT

Modello - Modèle - Model Modell - Modelo - Modelo	GRANVISTA INTEGRAL AIR	COSTAN eptarefrigeration
Fabbricante - Constructeur - Manufacturer Hersteller - Fabricante - Fabricante	Epta Spa - Via Mecenate, 86 - 20138 Milano (MI) ITALIA Tel. 02/55403211 Telefax 02/55401023	4/10

Cleaning instruction

IT 2. REINIGUNGSMITTEL

FR

Arbeitskleidung

- Schutzhandschuhe
- Schutzkleidung
- Schutzbrille

EN

DE

ES

Reinigungsmittel für andere Oberflächen als Glas

PT

- Wasser
- Mildes Reinigungsmittel
- Weiche Schwämme, Lappen und Tücher
(ohne raue Oberflächen)

Reinigungsmittel für Glasflächen

- Wasser
- Mildes Reinigungsmittel
- Handelsübliche Glasreiniger
- Ölfleckenentferner
- Weiche Schwämme, Lappen (ohne raue
Oberflächen) und Papiertücher

Die folgenden Mittel dürfen nicht eingesetzt werden:

- Stark korrosionsfördernde
Reinigungsmittel
- Säurehaltige oder ätzende
Reinigungsmittel
- Entflammbare Stoffe
- Azeton
- Lösungsmittelhaltige Reinigungsmittel
- Scheuermittel
- Hochdruckreiniger oder ein anderer
starker Wasserstrahl zur Reinigung

Modello - Modèle - Model Modell - Modelo - Modelo	GRANVISTA INTEGRAL AIR	COSTAN eptarefrigeration
Fabbricante - Constructeur - Manufacturer Hersteller - Fabricante - Fabricante	Epta Spa - Via Mecenate, 86 - 20138 Milano (MI) ITALIA Tel. 02/55403211 Telefax 02/55401023	5/10

3. REINIGUNG DER KÜHLMÖBEL

3.1 Reinigung der Außenflächen der Kühlmöbel

- Geben Sie für die Reinigung der Außenflächen der Kühlmöbel etwas Seife oder Reinigungsmittel in lauwarmes Wasser.
- Wischen Sie die Oberflächen vorsichtig ab, verwenden Sie dafür einen Schwamm oder Lappen ohne raue Oberfläche bzw. ein weiches Tuch.

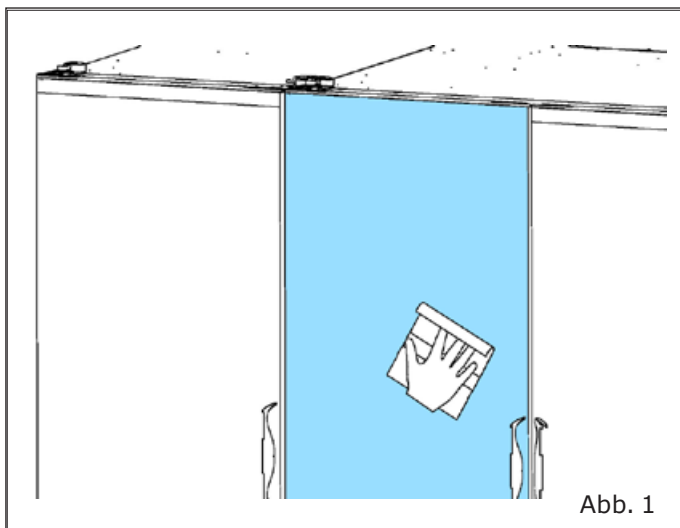

Reinigung der Glastüren und der Glaswände im Innenraum:

- Verwenden Sie einen handelsüblichen Glasreiniger und einen Schwamm oder Lappen ohne raue Oberflächen bzw. ein Papiertuch.

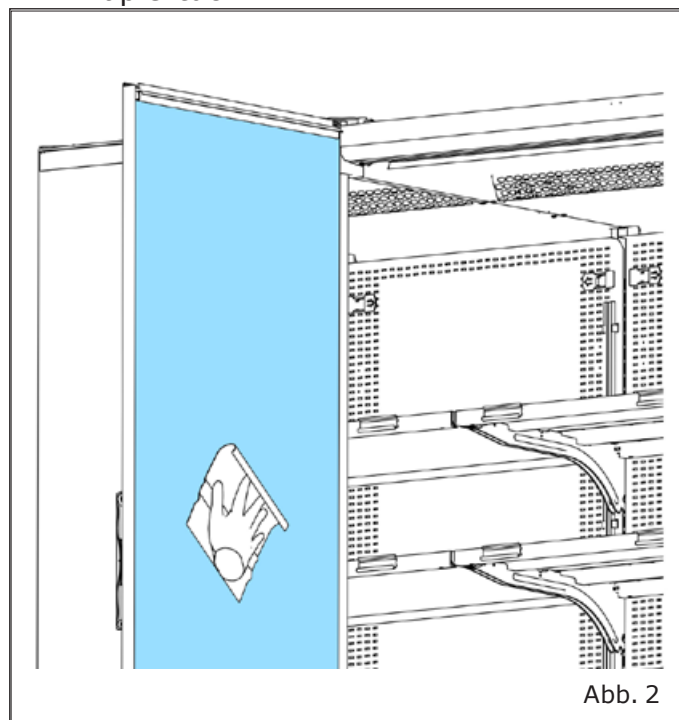

3.2 Reinigung des Kühlmöbel-Innenraums

- Legen Sie die Waren in eine Kühltruhe oder eine Kühlzelle.
- Vermeiden Sie eine Unterbrechung der Kühlkette.
- Trennen Sie das Gerät vom Stromnetz und stellen Sie sicher, dass der Strom keinesfalls durch unbefugte Personen wieder eingeschaltet wird.

 Fettige Rückstände müssen mit Ölfleckenentferner beseitigt werden.

Reinigung der Einlegeböden:

- Geben Sie für die Reinigung der Oberflächen etwas Seife oder Spülmittel in lauwarmes Wasser.

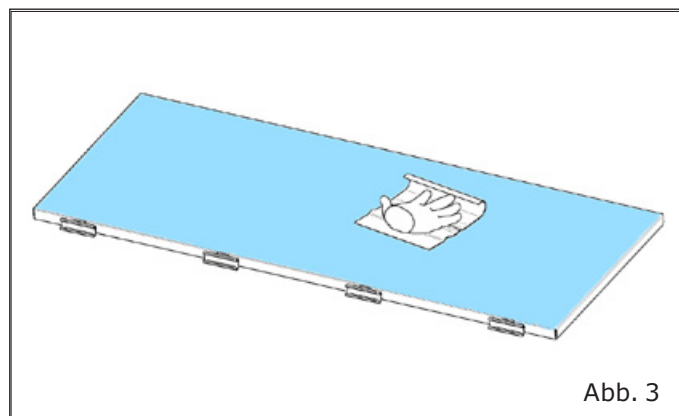

Modello - Modèle - Model Modell - Modelo - Modelo	GRANVISTA INTEGRAL AIR	COSTAN eptarefrigeration
Fabbricante - Constructeur - Manufacturer Hersteller - Fabricante - Fabricante	Epta Spa - Via Mecenate, 86 - 20138 Milano (MI) ITALIA Tel. 02/55403211 Telefax 02/55401023	6/10

Cleaning instruction

IT
FR
EN
DE
ES
PT

- Zur bequemeren Reinigung können Sie die Einlegeböden aus dem Regal herausnehmen.

Entfernen der beweglichen Teile im Kühlmöbel

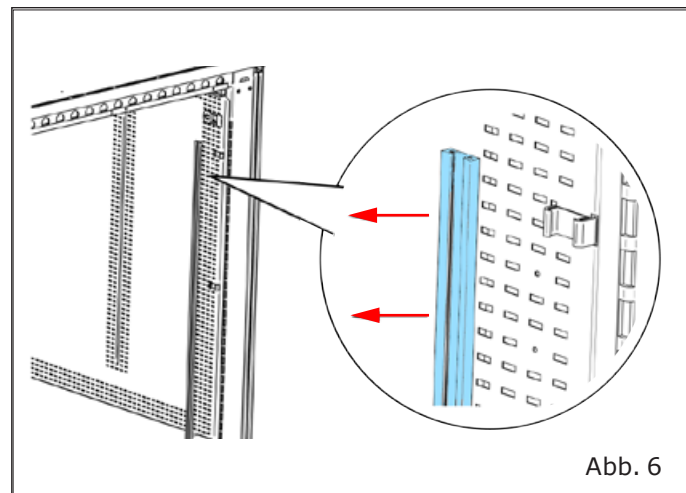
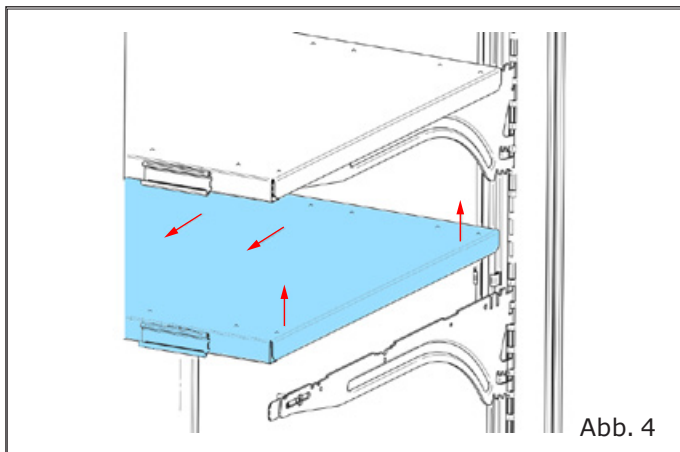

Bitte drehen Sie das Regal, um es aus dem Schrank zu nehmen.

- Vergewissern Sie sich, dass sich die Halterungen in der richtigen Position befinden und beim erneuten Einsetzen vollständig in den Trägern einrasten.

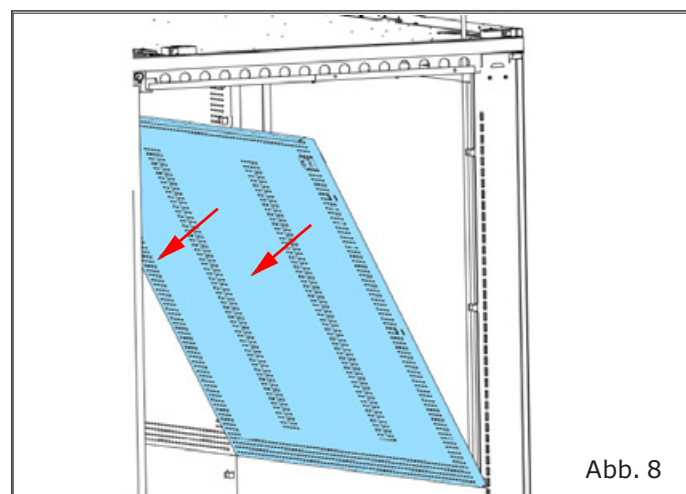
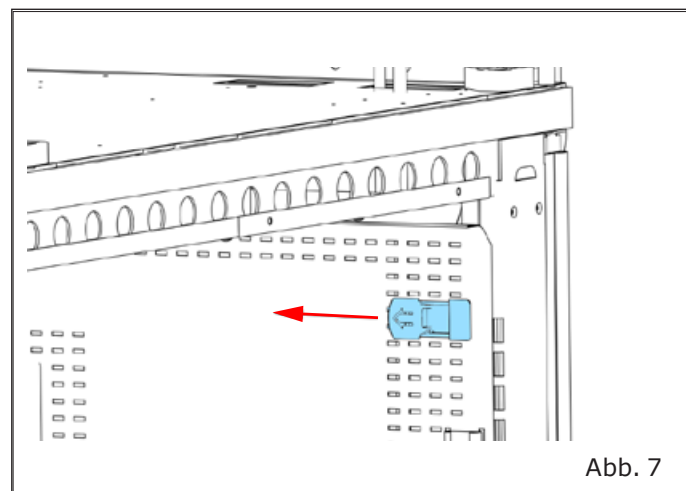
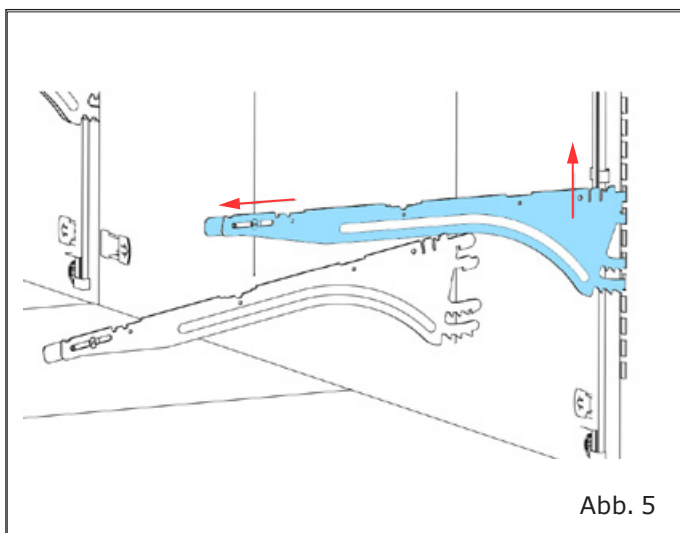

Modello - Modèle - Model Modell - Modelo - Modelo	GRANVISTA INTEGRAL AIR	COSTAN eptarefrigeration
Fabbricante - Constructeur - Manufacturer Hersteller - Fabricante - Fabricante	Epta Spa - Via Mecenate, 86 - 20138 Milano (MI) ITALIA Tel. 02/55403211 Telefax 02/55401023	7/10



Abb. 9



Abb. 10

3.3 Reinigung der Auslagefläche

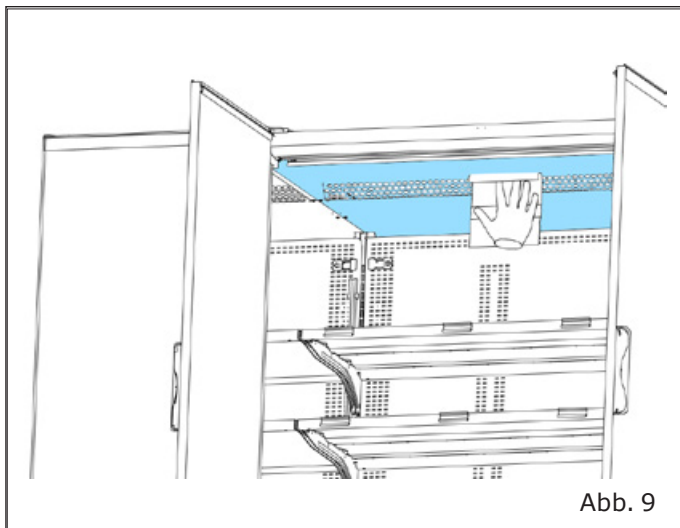

Die Reinigung der Auslagefläche darf nur durch geschultes Personal erfolgen.

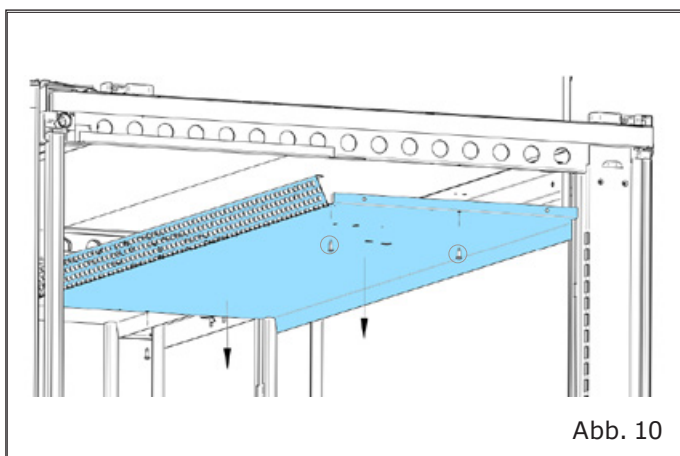
- Vermeiden Sie eine Unterbrechung der Kühlkette.
- Trennen Sie das Gerät vom Stromnetz und stellen Sie sicher, dass der Strom keinesfalls durch unbefugte Personen wieder eingeschaltet wird.
- Entfernen Sie das Lüftungsgitter und reinigen Sie es mit einem feuchten Tuch.



Abb. 11



Abb. 12

Cleaning instruction

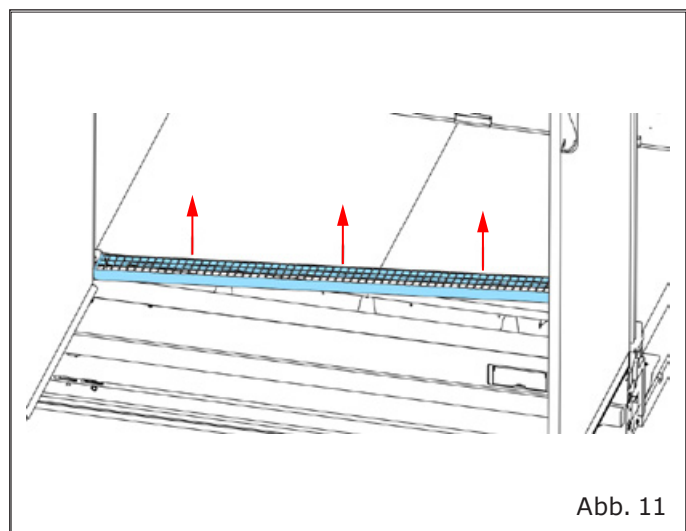
- Entfernen Sie die Auslagefläche.

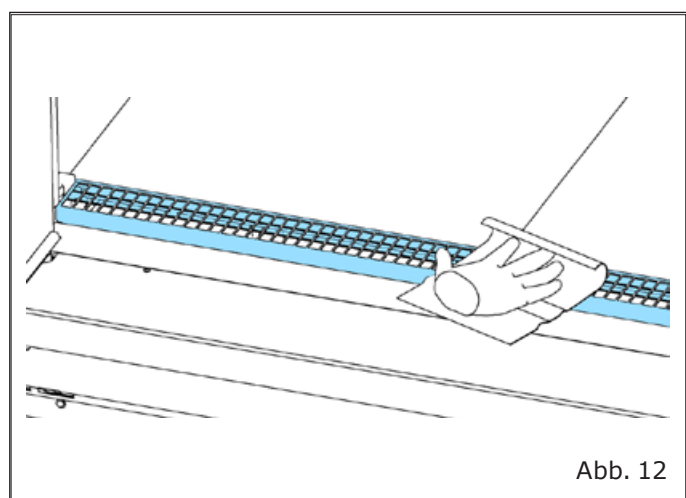

Abb. 13

- Reinigen Sie es mit einem feuchten Tuch



Abb. 14

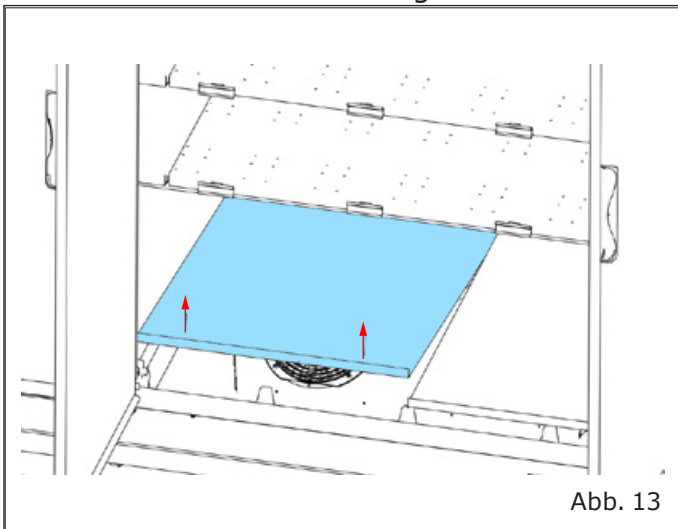

ACHTEN SIE AUF DIE ROTIERENDEN VERDAMPFERLÜFTER! BERÜHREN SIE DIE LÜFTER KEINESFALLS MIT DEN FINGERN, EINEM LAPPEN ODER EINEM ANDEREN HILFSMITTEL!

- Geben Sie für die Reinigung der Auslagefläche etwas Seife oder Reinigungsmittel in lauwarmes Wasser. Stellen Sie sicher, dass der Abfluss frei ist.

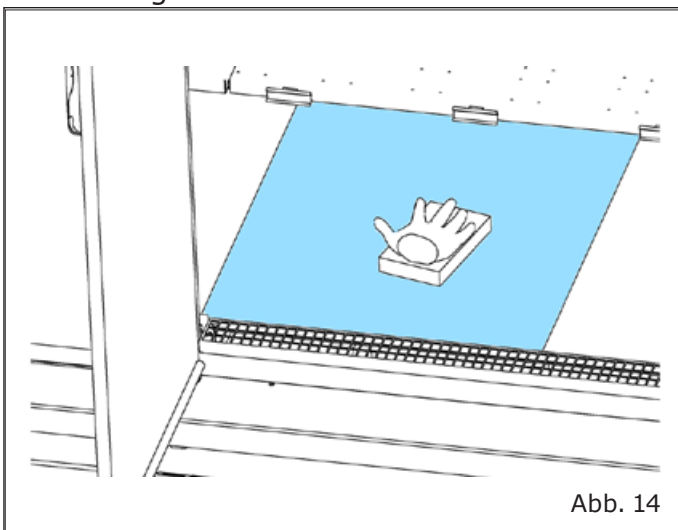

Abb. 15

- Saugen Sie das Innere des Abflusses mit einem Nasssauger aus, um alle Partikel zu entfernen.

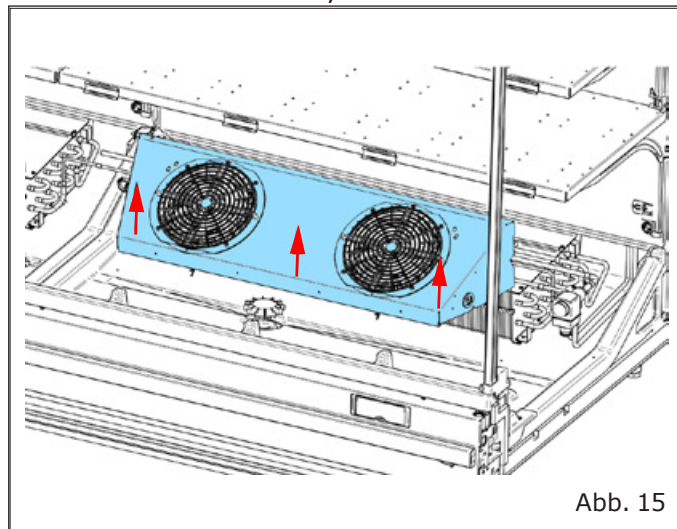

Abb. 16

Modello - Modèle - Model Modell - Modelo - Modelo	GRANVISTA INTEGRAL AIR	COSTAN eptarefrigeration
Fabbricante - Constructeur - Manufacturer Hersteller - Fabricante - Fabricante	Epta Spa - Via Mecenate, 86 - 20138 Milano (MI) ITALIA Tel. 02/55403211 Telefax 02/55401023	9/10

- Spülen Sie den Abfluss mit Wasser durch.

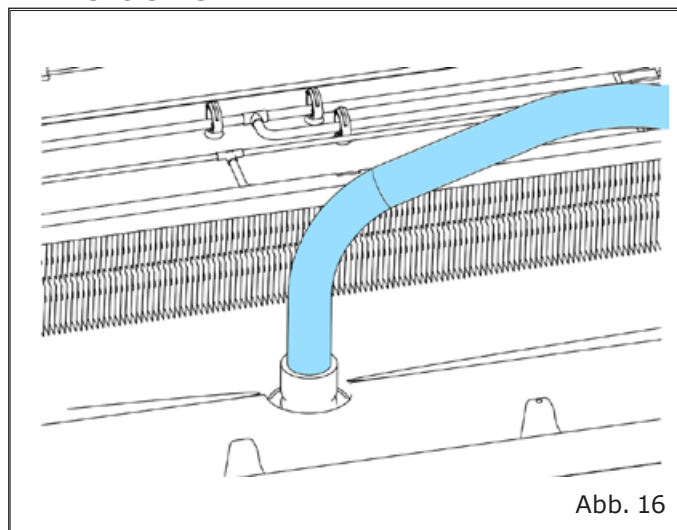
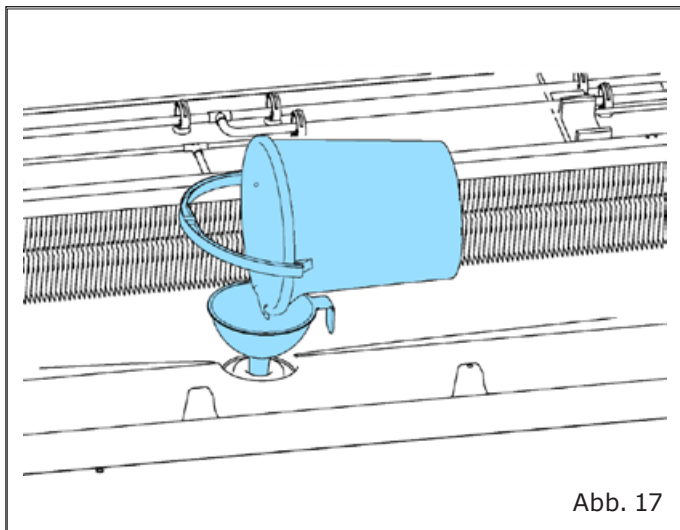

- Reinigen Sie die Ablauföffnung vollständig und spülen Sie sie mit fließendem Wasser aus.

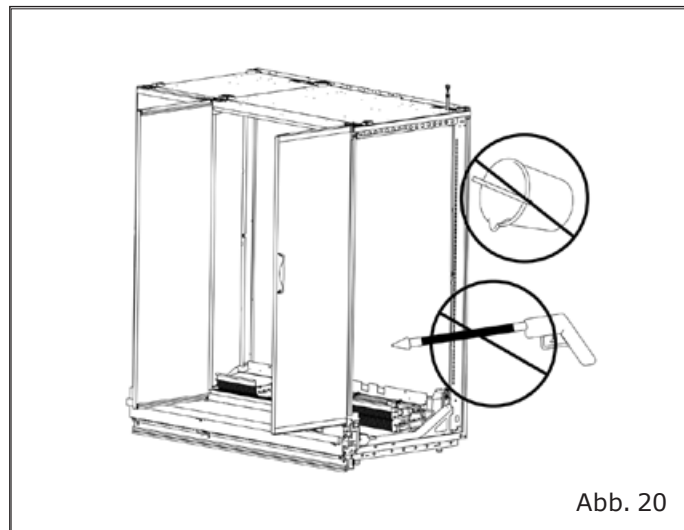
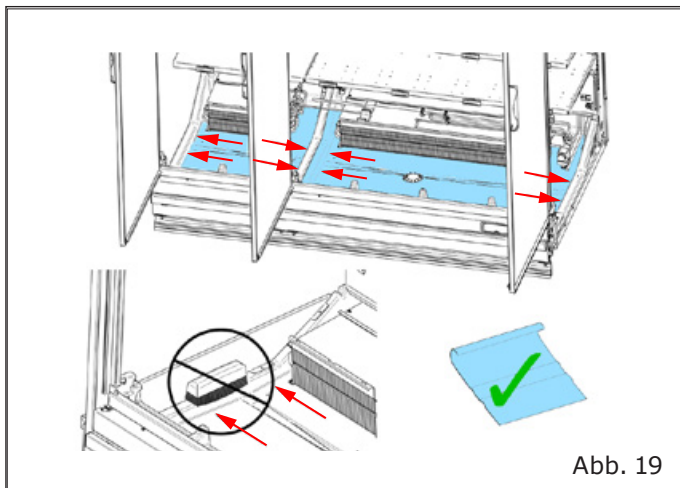
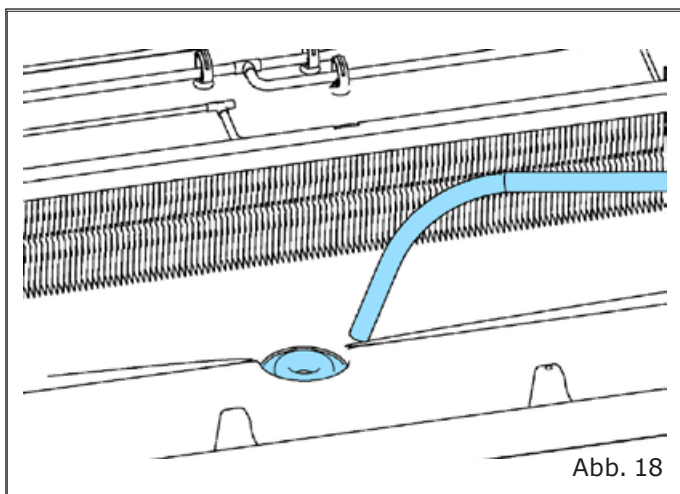

3.4 Reinigung des kondensators

- Wenn der Kondensator mit Staub verschmutzt ist, kann die Wärme nicht mehr abgegeben werden und das Gerät fällt aus. Aus diesem Grund sind eine regelmäßige Wartung und Reinigung unerlässlich.
- Wenn zwei Kühlmöbel back-to back montiert sind, entfernen Sie mit Hilfe einer Leiter die Abdeckung der Kondensatoren zwischen den beiden Möbeln.

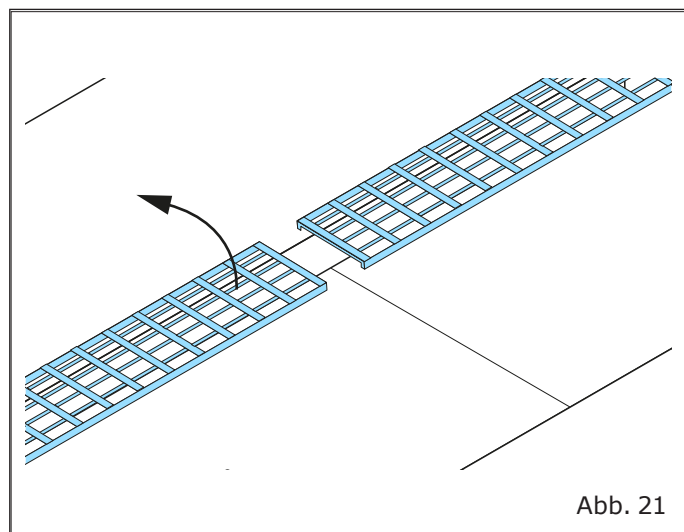

IT
FR
EN
DE
ES
PT

Modello - Modèle - Model Modell - Modelo - Modelo	GRANVISTA INTEGRAL AIR	COSTAN eptarefrigeration
Fabbricante - Constructeur - Manufacturer Hersteller - Fabricante - Fabricante	Epta Spa - Via Mecenate, 86 - 20138 Milano (MI) ITALIA Tel. 02/55403211 Telefax 02/55401023	10/10

Cleaning instruction

IT
FR
EN
DE
ES
PT

- Reinigen Sie den Kondensator mit einem Industriestaubsauger oder einem Handfeger.

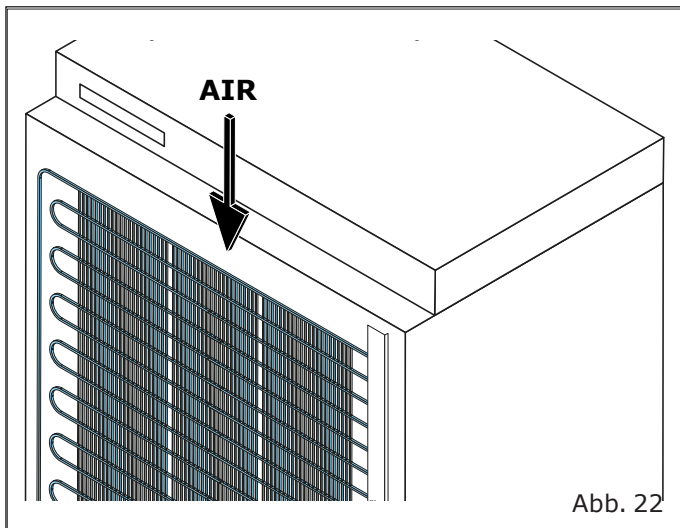

- Setzen Sie anschließend die Abdeckung wieder ein.
- Entfernen Sie das Lüftungsgitter

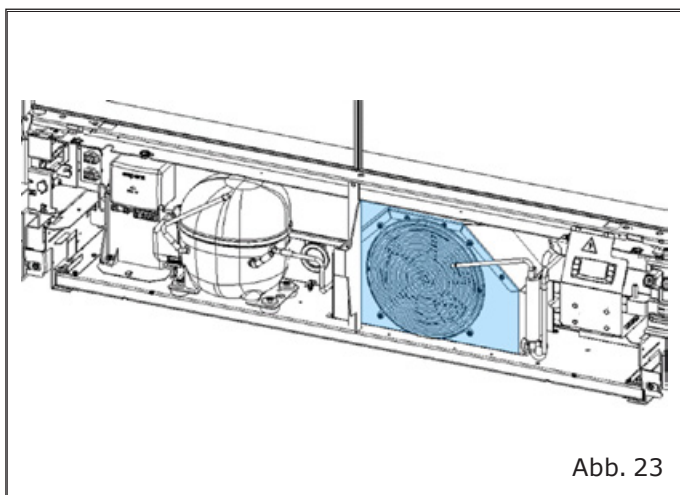

- Reinigung der Wanne

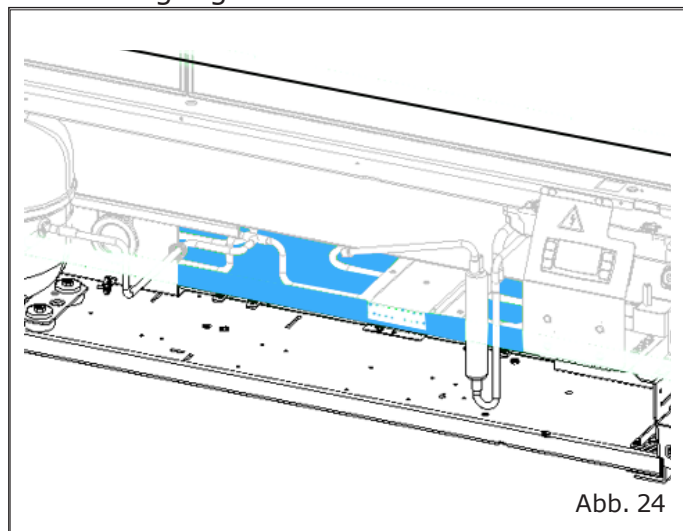

3.5 Zusammensetzen des Kühlmöbels

Es werden dieselben Schritte wie beim Abbau in umgekehrter Reihenfolge durchgeführt.

- Setzen Sie die Teile aus dem Innenraum und die Einlegeböden wieder ein.
- Vergewissern Sie sich, dass sich die Halterungen in der richtigen Position befinden und beim erneuten Einsetzen vollständig in den Trägern einrasten.
- Setzen Sie die Auslagefläche wieder ein.
- Setzen Sie die Lüftungsgitter wieder ein

3.6 Neustart des Kühlmöbels

- Nach erfolgter Reinigung stellen Sie sicher, dass das Innere des Kühlmöbels vollständig trocken ist. Erst dann schließen Sie es wieder an die Stromversorgung an und nehmen es in Betrieb.
- Der Kühlkreislauf startet. Warten Sie, bis die angezeigte Temperatur bei -3°C liegt, bevor Sie das Kühlmöbel befüllen.

Modello - Modèle - Model Modell - Modelo - Modelo	GRANVISTA INTEGRAL AIR	COSTAN eptarefrigeration
Fabbricante - Constructeur - Manufacturer Hersteller - Fabricante - Fabricante	Epta Spa - Via Mecenate, 86 - 20138 Milano (MI) ITALIA Tel. 02/55403211 Telefax 02/55401023	2/10

Cleaning instruction

ÍNDICE

IT

FR

EN

DE

ES

PT

1. Introducción	3
1.1 Alcance	3
1.2 Información general de seguridad	3
1.3 Razones para limpiar	3
2. Agentes de limpieza	4
3. Limpieza del aparato	5
3.1 Limpieza del exterior de la vitrina refrigerada	5
3.2 Limpieza del interior de la vitrina refrigerada	5
3.3 Limpieza de la plataforma base	7
3.4 limpieza del condensador	9
3.5 Asamblea de gabinete	10
3.6 Reinicio del gabinete	10

SÍMBOLOS UTILIZADOS



Símbolo de prohibición: se prohíbe realizar determinadas operaciones.



Símbolo de atención: normas de prevención de accidentes para el operador.



Símbolo de advertencia: posibilidad de dañar el mueble y/o sus componentes.



Símbolo de nota: proporciona información útil.

Equipo de protección personal

	Zapatos de seguridad
	Guantes protectores
	Lentes de seguridad
	Casco de seguridad
	Chalecos de seguridad

Modello - Modèle - Model Modell - Modelo - Modelo	GRANVISTA INTEGRAL AIR	COSTAN eptarefrigeration
Fabbricante - Constructeur - Manufacturer Hersteller - Fabricante - Fabricante	Epta Spa - Via Mecenate, 86 - 20138 Milano (MI) ITALIA Tel. 02/55403211 Telefax 02/55401023	3/10

1. INTRODUCCIÓN

1.1 Alcance

El documento "Instrucciones de limpieza" indica cómo limpiar la vitrina refrigerada. También contiene información sobre cómo proteger la seguridad de las personas a cargo de la limpieza.

Las instrucciones de uso también están disponibles en:
www.eptarefrigeration.com.

1.2 Información general de seguridad



No interrumpa nunca la cadena de refrigeración de los productos expuestos.



Antes de iniciar cualquier mantenimiento o limpieza, desconecte el equipo de la fuente de alimentación eléctrica y asegúrelo contra la reconexión por parte de personas no autorizadas.



Asegúrese de que el área de trabajo esté suficientemente iluminada durante las actividades de mantenimiento y limpieza y utilice una fuente de iluminación adicional si es necesario.



Las puertas y las paredes de vidrio están provistas de una película de revestimiento antivaho en el interior. No utilice ningún detergente que contenga sustancias abrasivas, fuertemente ácidas o cáusticas.



Tenga cuidado de tocar cualquier parte giratoria del gabinete (ventiladores) con los dedos, toallas u otras herramientas.



No retire ninguna protección ni cubierta.

1.3 Razones para limpiar

Para presentar los productos de forma atractiva e higiénica, es importante limpiar el armario del congelador con regularidad. La limpieza regular también evita que el moho y las bacterias dañinas se asienten en los muebles, ya que el polvo húmedo proporciona un caldo de cultivo ideal.

La limpieza regular también es esencial para la función técnica. Esta es la única forma de garantizar que se produzca un intercambio de calor óptimo y que el aire pueda fluir fácilmente en el armario.

IT

FR

EN

DE

ES

PT

Modello - Modèle - Model Modell - Modelo - Modelo	GRANVISTA INTEGRAL AIR	COSTAN  eptarefrigeration
Fabbricante - Constructeur - Manufacturer Hersteller - Fabricante - Fabricante	Epta Spa - Via Mecenate, 86 - 20138 Milano (MI) ITALIA Tel. 02/55403211 Telefax 02/55401023	4/10

Cleaning instruction

IT 2. AGENTES DE LIMPIEZA

FR

Ropa de trabajo

- Guantes protectores
- Ropa protectora
- Lentes de seguridad

EN

DE

ES

Agente de limpieza para superficies que no sean de vidrio

PT

- Agua
- Detergente suave
- Esponjas, trapos y paños suaves que no rayen

Agente de limpieza para superficies de vidrio.

- Agua
- Detergente suave
- Limpiacristales estándar
- Quitamanchas de aceite
- Esponjas, trapos y toallas de papel que no rayan

No se debe utilizar lo siguiente

- Agentes de limpieza corrosivos fuertes
- Agentes de limpieza ácidos o cáusticos
- Agentes inflamables
- Acetona
- Agentes de limpieza que contienen disolventes
- Limpiadores abrasivos
- Limpiador a chorro u otro chorro de agua fuerte para limpiar

Modello - Modèle - Model Modell - Modelo - Modelo	GRANVISTA INTEGRAL AIR	COSTAN eptarefrigeration
Fabbricante - Constructeur - Manufacturer Hersteller - Fabricante - Fabricante	Epta Spa - Via Mecenate, 86 - 20138 Milano (MI) ITALIA Tel. 02/55403211 Telefax 02/55401023	5/10

3. LIMPIEZA DEL APARATO

3.1 Limpieza del exterior de la vitrina refrigerada

- Limpie las superficies exteriores de la vitrina con jabón suave o detergente solo con agua tibia.
- Limpie cuidadosamente con esponjas que no rayen, trapos y paños suaves.

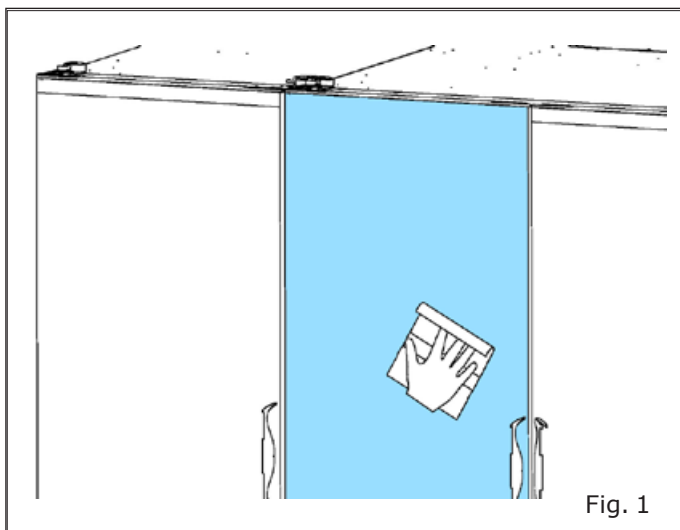

3.2 Limpieza del interior de la vitrina refrigerada

- Retire los productos expuestos y guárdelos en frigoríficos o cámaras frigoríficas.
- Evite interrumpir la cadena de refrigeración.
- Desconecte el armario de la fuente de alimentación eléctrica y asegúrelo contra la reconexión por parte de personas no autorizadas.

Limpieza de las puertas de cristal y paredes de cristal en el interior:

- Límpielo con un limpiacristales estándar con una esponja no abrasiva, un trapo o una toalla de papel.

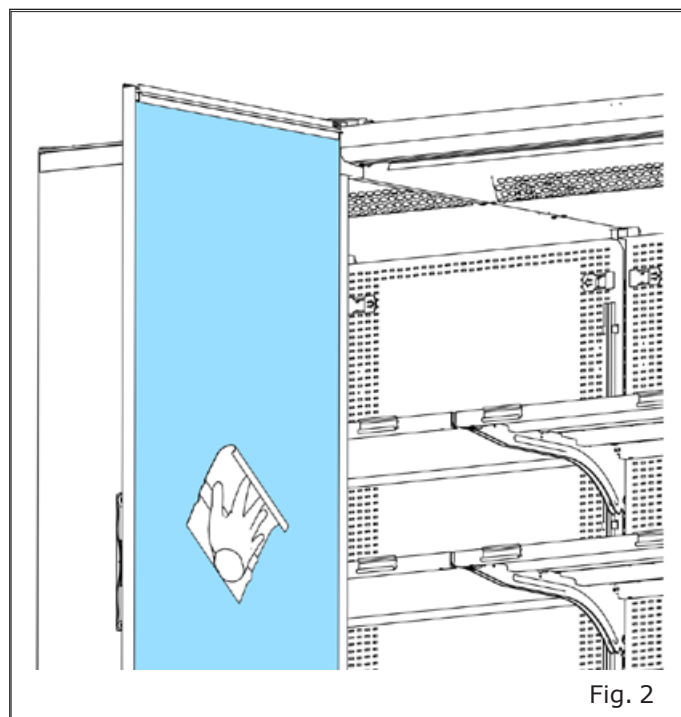

Los restos de grasa deben eliminarse con quitamanchas de aceite.

Limpieza de los estantes:

- Las superficies se pueden limpiar con jabón suave o detergente en agua tibia.

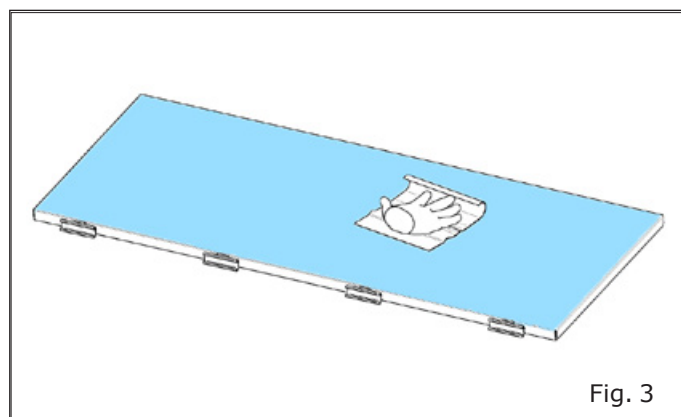

Cleaning instruction

- Para una limpieza conveniente, puede separar los estantes y sacarlos del estante.

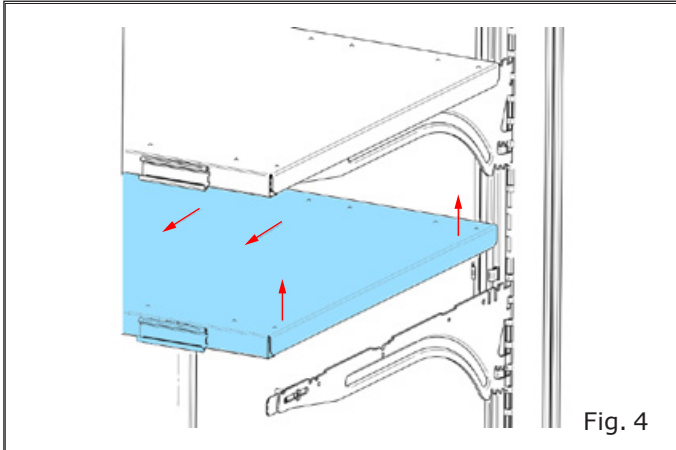

Gire el estante para extraerlo del gabinete.

- Asegúrese de que los soportes estén en la posición correcta y que los soportes encajen completamente en el soporte cuando los vuelva a colocar.

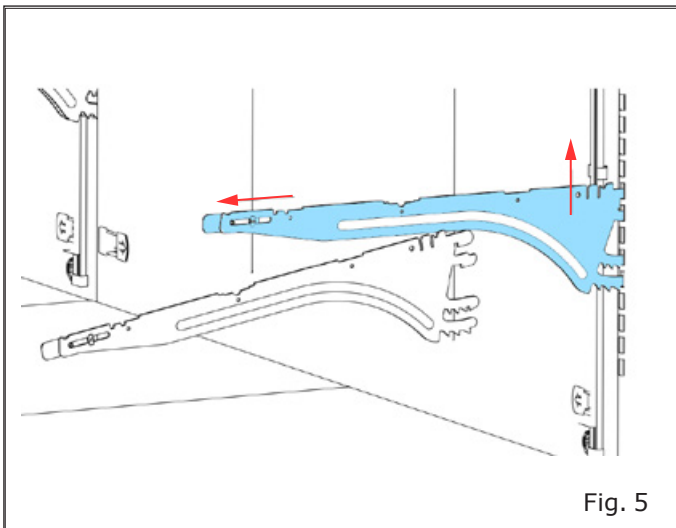

Eliminación de la estructura interna.

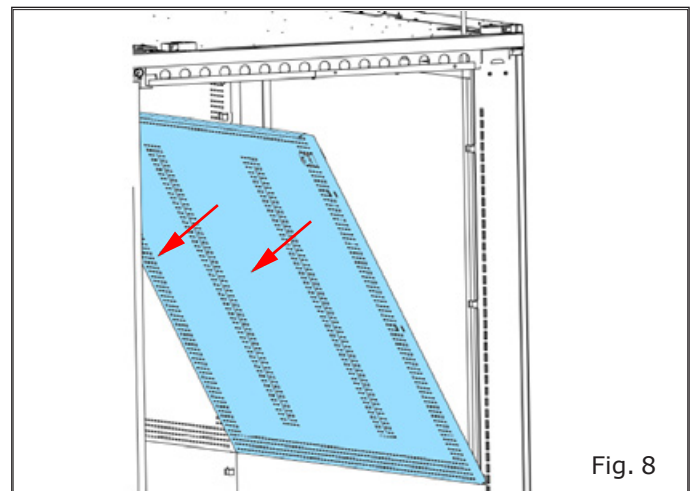
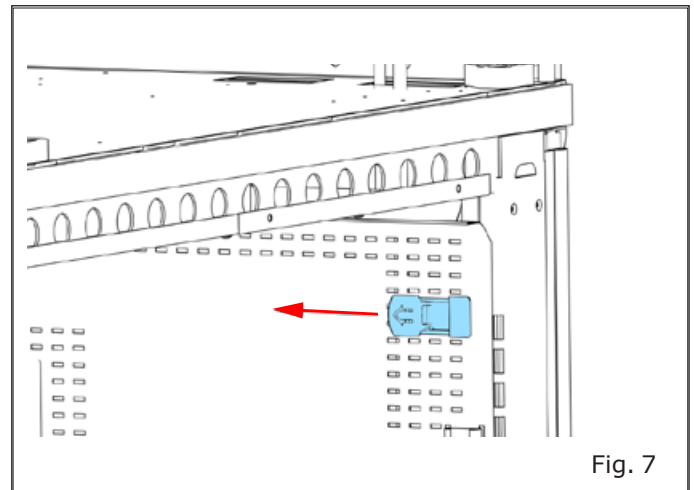
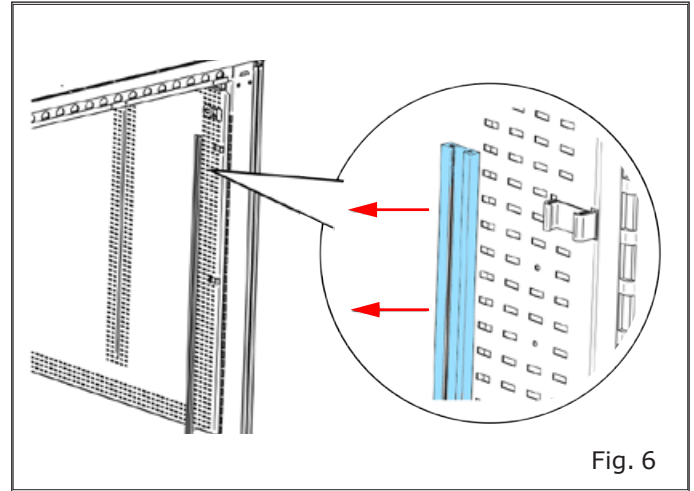

Modello - Modèle - Model Modell - Modelo - Modelo	GRANVISTA INTEGRAL AIR	COSTAN eptarefrigeration
Fabbricante - Constructeur - Manufacturer Hersteller - Fabricante - Fabricante	Epta Spa - Via Mecenate, 86 - 20138 Milano (MI) ITALIA Tel. 02/55403211 Telefax 02/55401023	7/10

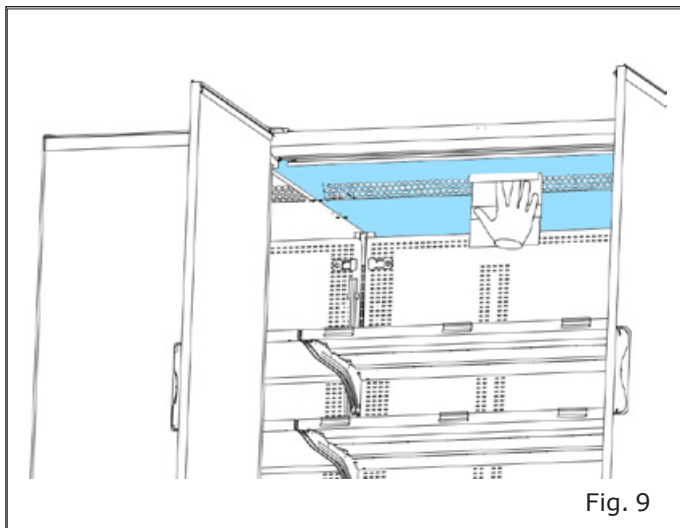

Fig. 9

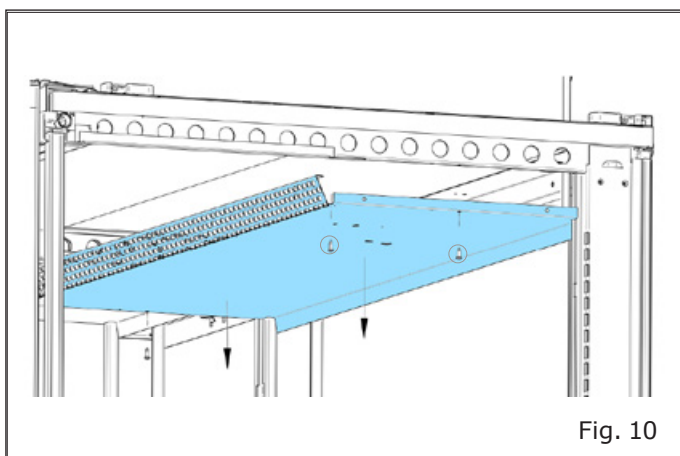

Fig. 10

3.3 Limpieza de la plataforma base



La limpieza de la plataforma base debe ser realizada únicamente por personal capacitado.

- Evite interrumpir la cadena de refrigeración.
- Desconecte el armario de la fuente de alimentación eléctrica y asegúrelo contra la reconexión por parte de personas no autorizadas.
- Retire las rejillas de retorno de aire y límpielas con un trapo húmedo.

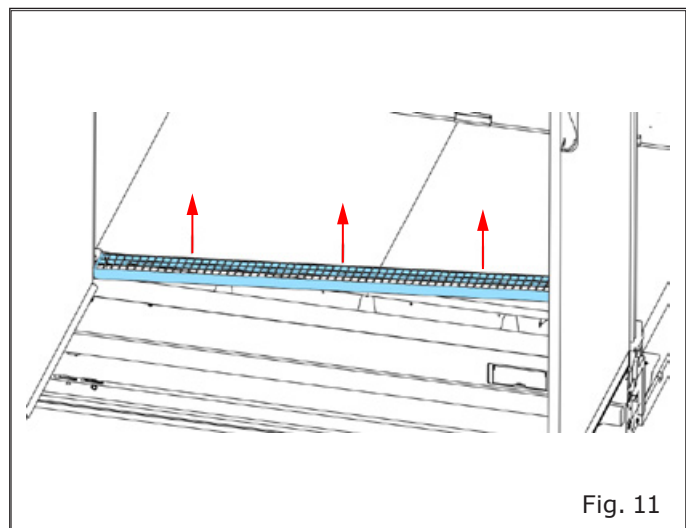

Fig. 11

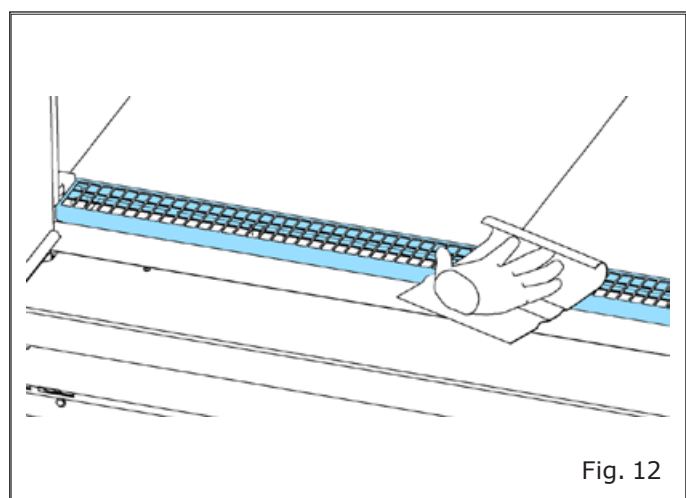
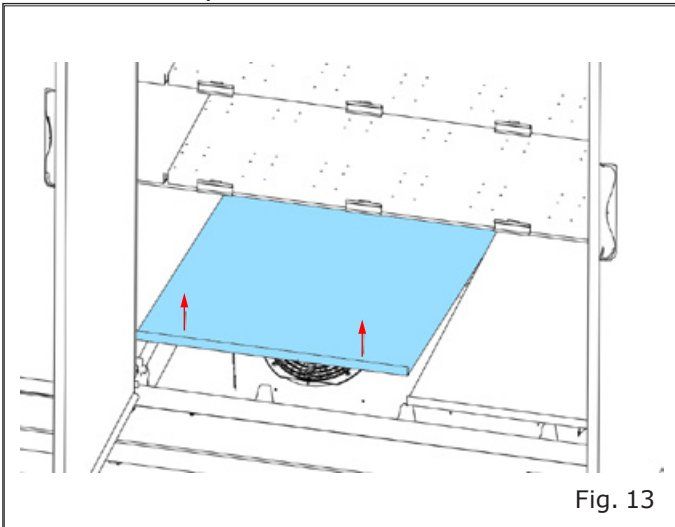

Fig. 12

Cleaning instruction

- Retire la plataforma base.



- Límpielo con un trapo húmedo.

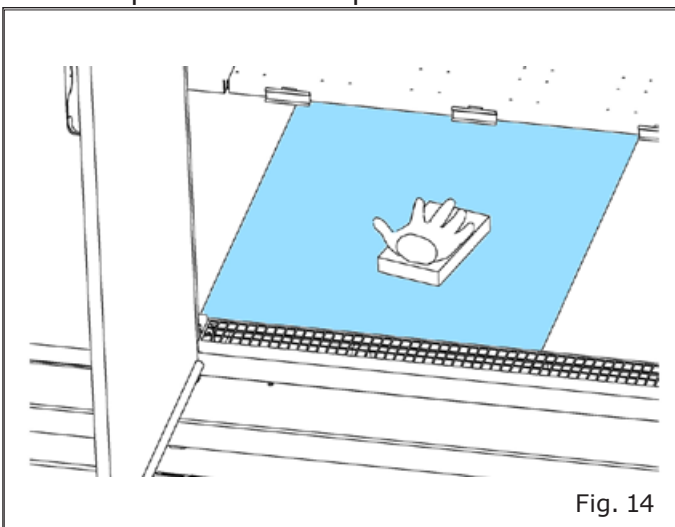

¡Tenga cuidado con los ventiladores rotatorios del evaporador! No los toque con los dedos, trapos u otras herramientas.

- Limpie la bandeja base con jabón suave o detergente en agua tibia. Compruebe que el desagüe no esté obstruido.

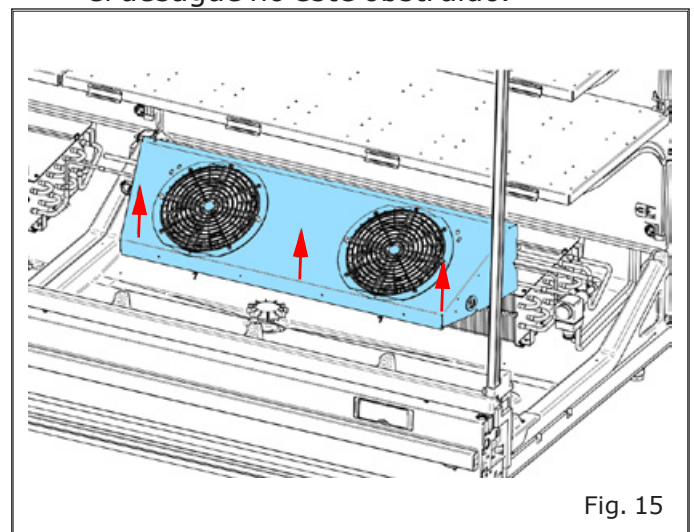

- aspire dentro del drenaje con una aspiradora húmeda para eliminar cualquier partícula.

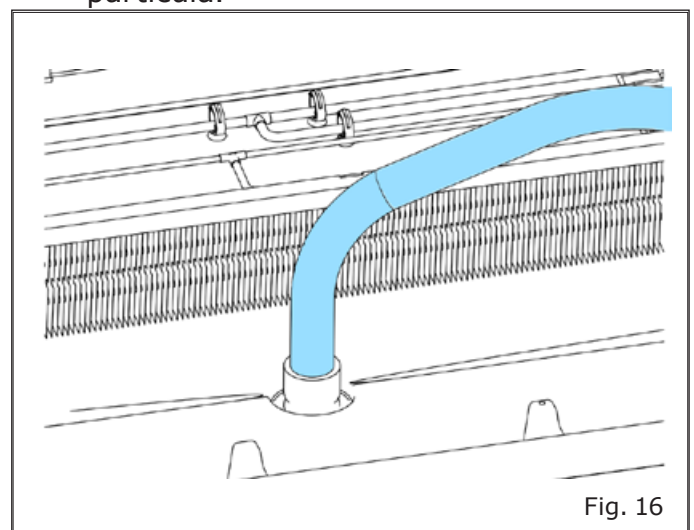

Modello - Modèle - Model Modell - Modelo - Modelo	GRANVISTA INTEGRAL AIR	COSTAN eptarefrigeration
Fabbricante - Constructeur - Manufacturer Hersteller - Fabricante - Fabricante	Epta Spa - Via Mecenate, 86 - 20138 Milano (MI) ITALIA Tel. 02/55403211 Telefax 02/55401023	9/10

- Enjuague el desagüe con agua.

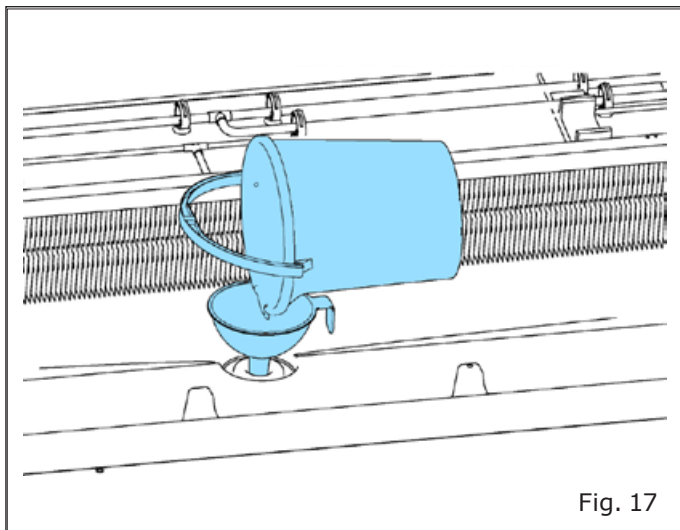

Fig. 17

- Limpie la abertura de drenaje completamente y enjuague con agua corriente.

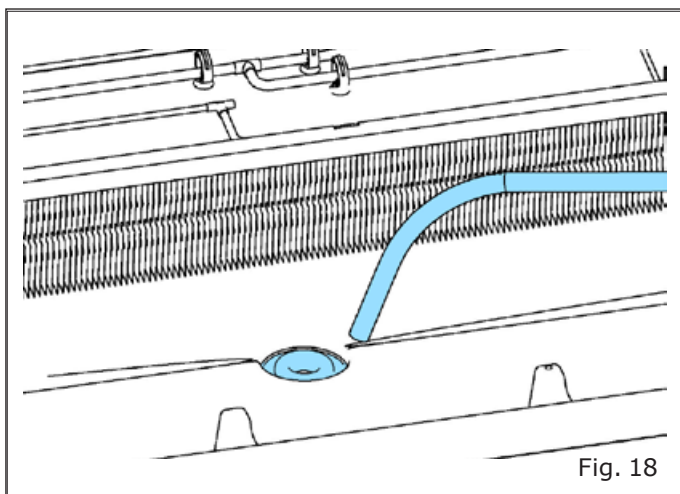

Fig. 18

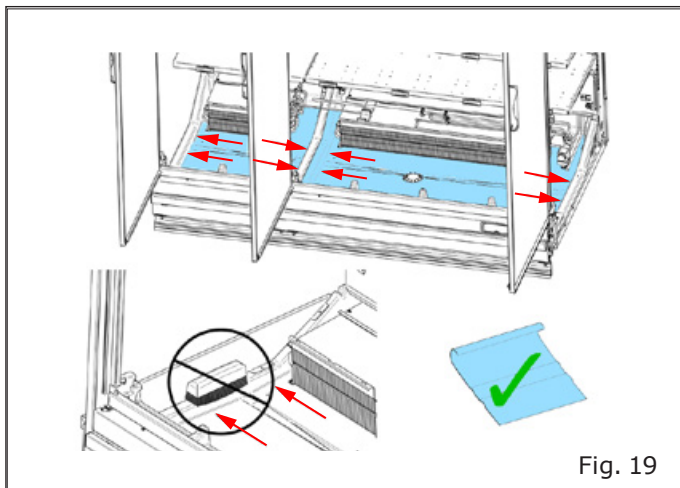

Fig. 19

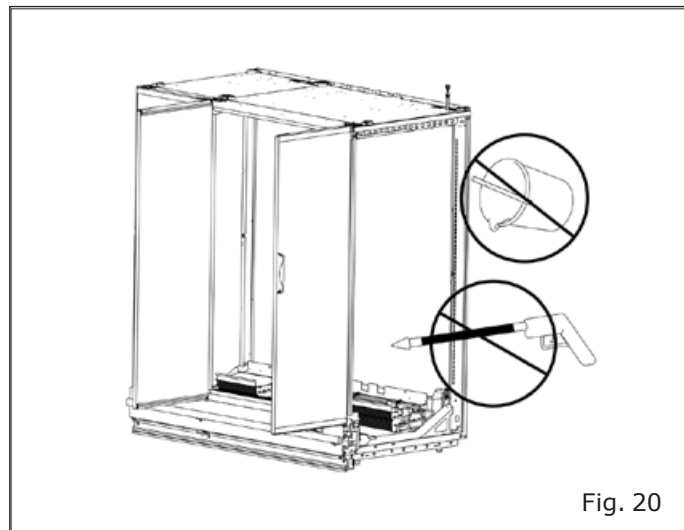

Fig. 20

3.4 limpieza del condensador

- Si el condensador se ensucia con polvo, el calor ya no se puede disipar y el congelador puede fallar. Por lo tanto, es necesaria una inspección y limpieza regulares.
- En el caso de una configuración espalda con espalda, con una escalera, retire la máscara del condensador entre los dos gabinetes desde la parte superior.

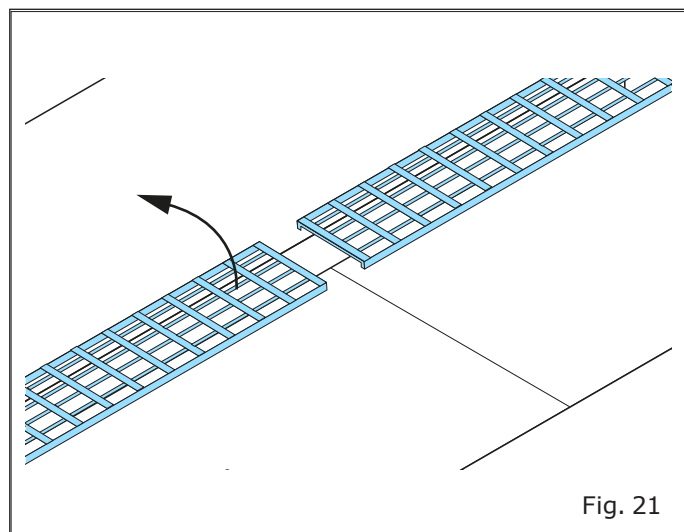

Fig. 21

Modello - Modèle - Model Modell - Modelo - Modelo	GRANVISTA INTEGRAL AIR	COSTAN eptarefrigeration
Fabbricante - Constructeur - Manufacturer Hersteller - Fabricante - Fabricante	Epta Spa - Via Mecenate, 86 - 20138 Milano (MI) ITALIA Tel. 02/55403211 Telefax 02/55401023	10/10

Cleaning instruction

IT
FR
EN
DE
ES
PT

- Limpie el condensador con una aspiradora industrial o un cepillo de mano.

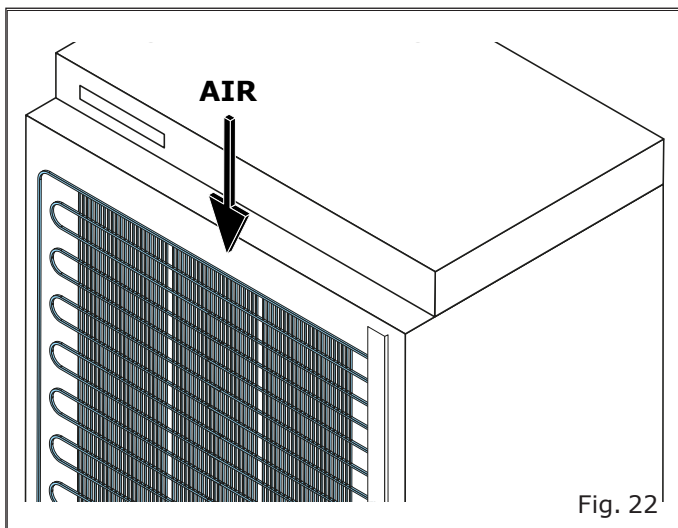

- Luego reinstale la máscara del condensador.
- Retire el deflector del ventilador.

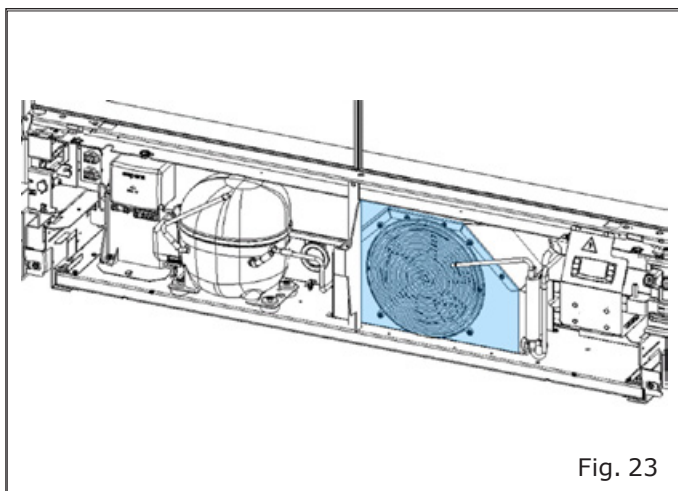

- Limpieza de cuencos

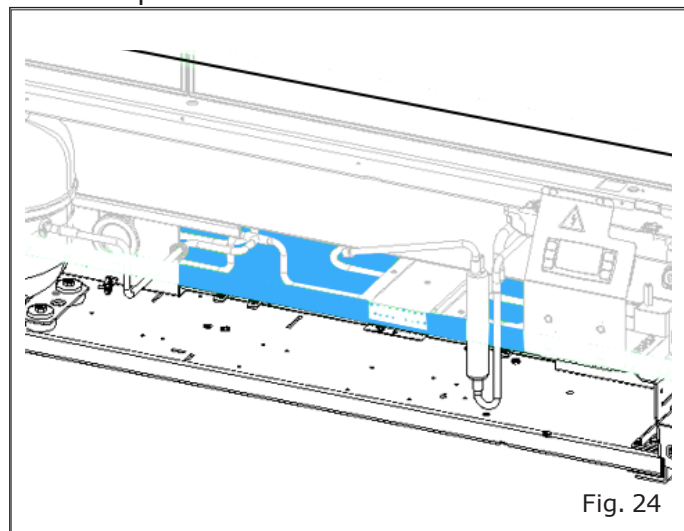

3.5 Asamblea de gabinete

Siga las mismas fases de desmontaje en orden inverso:

- Vuelva a instalar la estructura interna y los estantes.
- Asegúrese de que los soportes estén en la posición correcta y que los soportes encajen completamente en el soporte cuando los vuelva a colocar.
- Vuelva a instalar la plataforma base.
- Vuelva a instalar la rejilla de retorno de aire.

3.6 Reinicio del gabinete

- Después de completar la limpieza y verificar atentamente que el interior del mueble está completamente seco, vuelva a poner en funcionamiento el aparato volviendo a conectar la alimentación al mueble.
- El gabinete entonces comenzará su ciclo de enfriamiento. Permita que los gabinetes alcancen una temperatura mostrada de -3°C antes de volver a cargar los artículos retirados.

Modello - Modèle - Model Modell - Modelo - Modelo	GRANVISTA INTEGRAL AIR	COSTAN eptarefrigeration
Fabbricante - Constructeur - Manufacturer Hersteller - Fabricante - Fabricante	Epta Spa - Via Mecenate, 86 - 20138 Milano (MI) ITALIA Tel. 02/55403211 Telefax 02/55401023	2/10

Cleaning instruction

ÍNDICE

IT

FR

EN

DE

ES

PT

1. Introdução	2
1.1 Alcance	2
1.2 Informações gerais de segurança	2
1.3 Motivos da limpeza	2
2. Agentes de limpeza	3
3. Limpando o aparelho	4
3.1 Limpeza do exterior do expositor refrigerado	4
3.2 Limpeza do interior da vitrine refrigerada	4
3.3 Limpeza do deck base	6
3.4 Limpeza do condensador	8
3.5 montagem do gabinete	9
3.6 Reinício do gabinete	9

SIMBOLOGIA UTILIZADA



Símbolo proibição: proíbe efetuar determinadas operações.



Símbolo atenção: normas contra acidentes para o operador.



Símbolo advertências: existe a possibilidade de danificar o balcão e/ou os seus componentes.



Símbolo nota: fornece informações úteis.

Equipamento de proteção pessoal

	Sapatos de segurança
	Luvas de proteção
	Óculos de segurança
	Capacete de segurança
	Coletes de segurança

Modello - Modèle - Model Modell - Modelo - Modelo	GRANVISTA INTEGRAL AIR	COSTAN eptarefrigeration
Fabbricante - Constructeur - Manufacturer Hersteller - Fabricante - Fabricante	Epta Spa - Via Mecenate, 86 - 20138 Milano (MI) ITALIA Tel. 02/55403211 Telefax 02/55401023	3/10

1. INTRODUÇÃO

1.1 Alcance

O documento "Instruções de limpeza" indica como limpar a vitrine refrigerada. Ele também contém informações sobre como proteger a segurança das pessoas encarregadas da limpeza.

As instruções de uso também estão disponíveis em:
www.eptarefrigeration.com.

1.2 Informações gerais de segurança



Nunca interrompa a cadeia de refrigeração dos produtos expostos.



Antes de iniciar qualquer manutenção ou limpeza, desconecte o equipamento da rede elétrica e proteja-o contra religação por pessoas não autorizadas.



Certifique-se de que a área de trabalho esteja suficientemente iluminada durante as atividades de manutenção e limpeza e use uma fonte de iluminação adicional, se necessário.



As portas e paredes de vidro são fornecidas com uma película anti-embaciamento no interior. Não use nenhum detergente que contenha substâncias abrasivas, fortemente ácidas ou cáusticas.



Cuidado ao tocar em qualquer parte rotativa do gabinete (ventiladores) com os dedos, toalhas ou outras ferramentas.



Não remova quaisquer proteções e tampas de proteção.

1.3 Motivos da limpeza

Para apresentar os produtos de forma atrativa e higiênica, é importante limpar regularmente o gabinete do freezer. A limpeza regular também evita que o mofo e as bactérias nocivas se instalem nos móveis, pois a poeira úmida é um terreno fértil ideal.

A limpeza regular também é essencial para a função técnica. Esta é a única maneira de garantir que ocorra uma troca de calor ideal e que o ar possa fluir facilmente no gabinete.

IT

FR

EN

DE

ES

PT

Modello - Modèle - Model Modell - Modelo - Modelo	GRANVISTA INTEGRAL AIR	COSTAN  eptarefrigeration
Fabbricante - Constructeur - Manufacturer Hersteller - Fabricante - Fabricante	Epta Spa - Via Mecenate, 86 - 20138 Milano (MI) ITALIA Tel. 02/55403211 Telefax 02/55401023	4/10

Cleaning instruction

IT

2. AGENTES DE LIMPEZA

FR

Roupas de trabalho

- Luvas de proteção
- Roupa de proteção
- Óculos de segurança

EN

DE

ES

Agente de limpeza para superfícies que não sejam vidro

PT

- Água
- Detergente suave
- Esponjas, panos e panos macios que não arranhem

Agente de limpeza para superfícies de vidro

- Água
- Detergente suave
- Limpador de vidro padrão
- Removedores de manchas de óleo
- Esponjas, panos e toalhas de papel que não riscam

O seguinte não deve ser usado

- Agentes de limpeza corrosivos fortes
- Agentes de limpeza ácidos ou cáusticos
- Agentes inflamáveis
- Acetona
- Agentes de limpeza contendo solvente
- Limpadores abrasivos
- Limpador de lavagem a jato ou outro jato de água forte para limpar

Modello - Modèle - Model Modell - Modelo - Modelo	GRANVISTA INTEGRAL AIR	COSTAN eptarefrigeration
Fabbricante - Constructeur - Manufacturer Hersteller - Fabricante - Fabricante	Epta Spa - Via Mecenate, 86 - 20138 Milano (MI) ITALIA Tel. 02/55403211 Telefax 02/55401023	5/10

3. LIMPANDO O APARELHO

3.1 Limpeza do exterior do expositor refrigerado

- Limpe as superfícies externas da vitrine com sabão neutro ou detergente apenas em água morna.
- Limpe cuidadosamente com esponjas, panos e panos macios que não risquem.

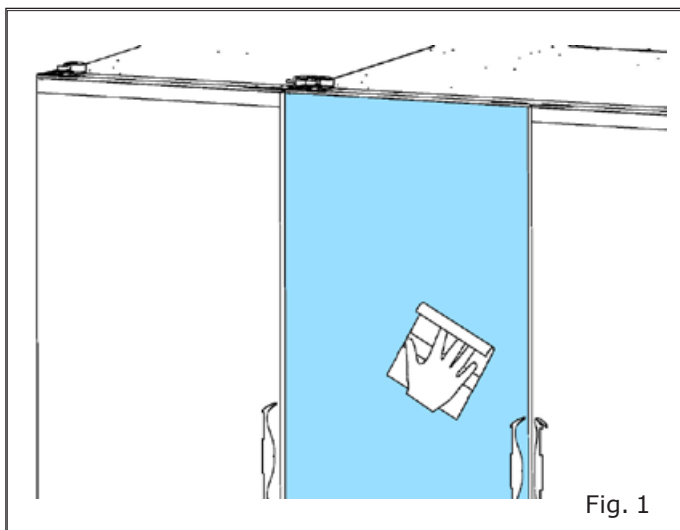

3.2 Limpeza do interior da vitrine refrigerada

- Remova os produtos expostos e armazene-os em geladeiras ou salas refrigeradas.
- Evite interromper a cadeia de refrigeração.
- Desconecte o gabinete da fonte de alimentação elétrica e proteja-o contra reconexão por pessoas não autorizadas.

Limpeza das portas de vidro e paredes de vidro no interior:

- Limpe-o usando um limpador de vidro padrão com uma esponja não abrasiva, um pano ou uma toalha de papel.

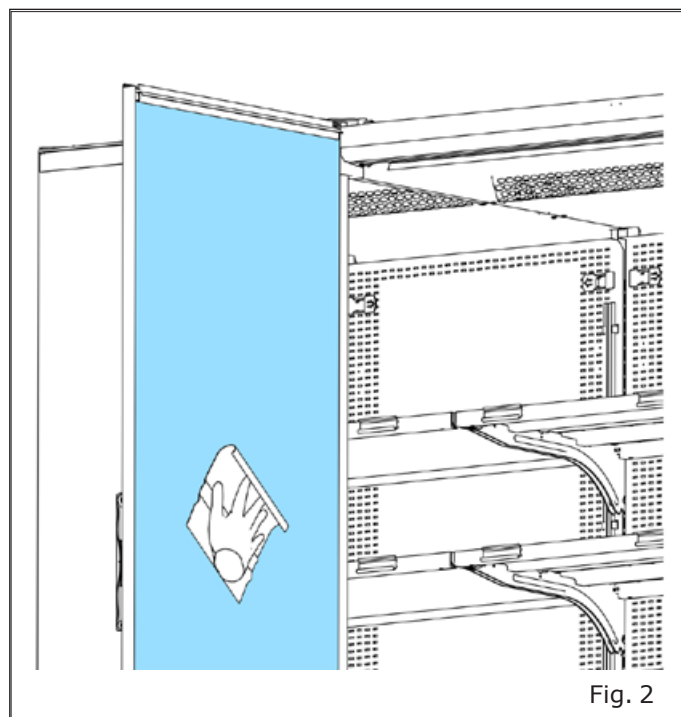

Resíduos gordurosos devem ser removidos com removedor de manchas de óleo.

Limpeza das prateleiras:

- As superfícies podem ser limpas com sabão neutro ou detergente em água morna.

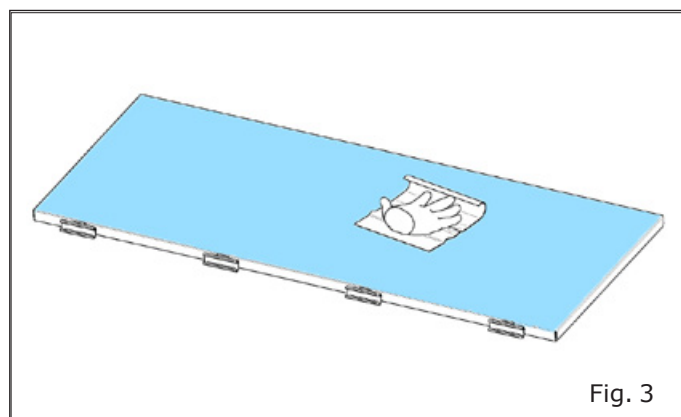

Cleaning instruction

- Para uma limpeza conveniente, você pode destacar as prateleiras e retirá-las do rack.

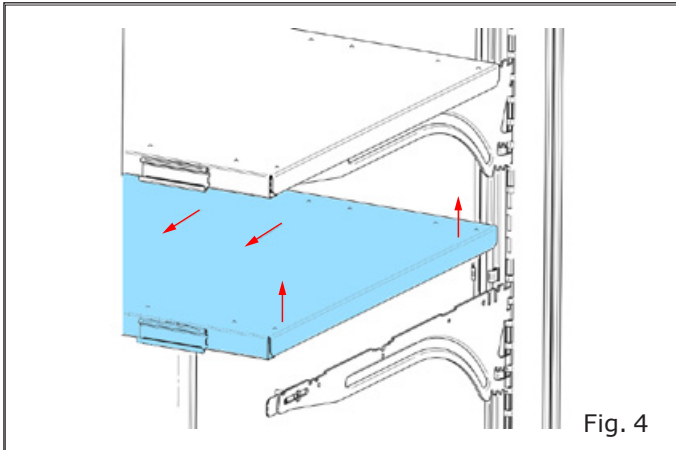

Por favor, gire a prateleira para extraí-la do armário.

- Certifique-se de que os suportes estão na posição correta e que os suportes travam completamente no suporte ao reinstalá-los.

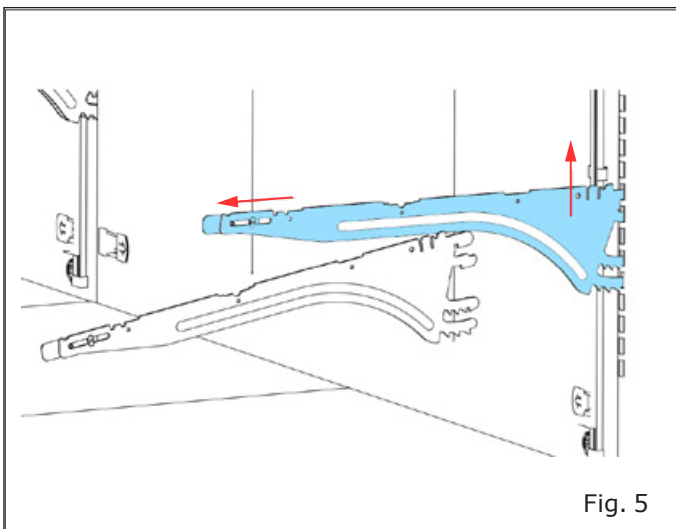

Remoção da estrutura interna

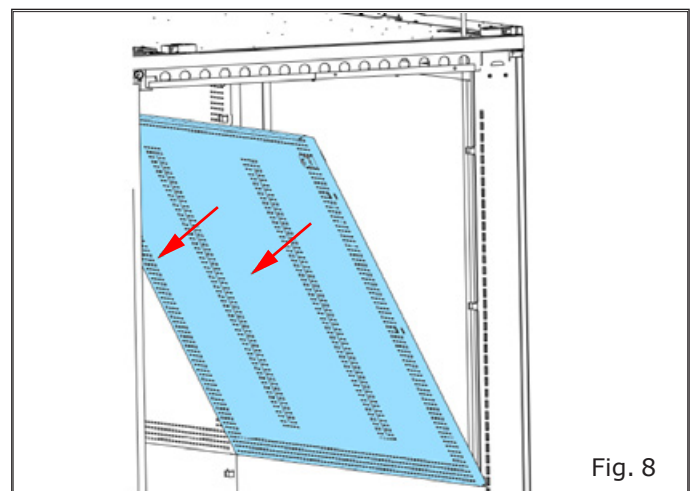
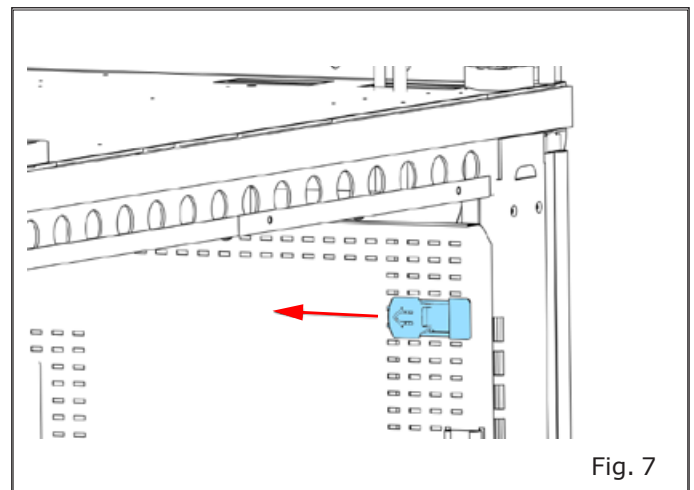
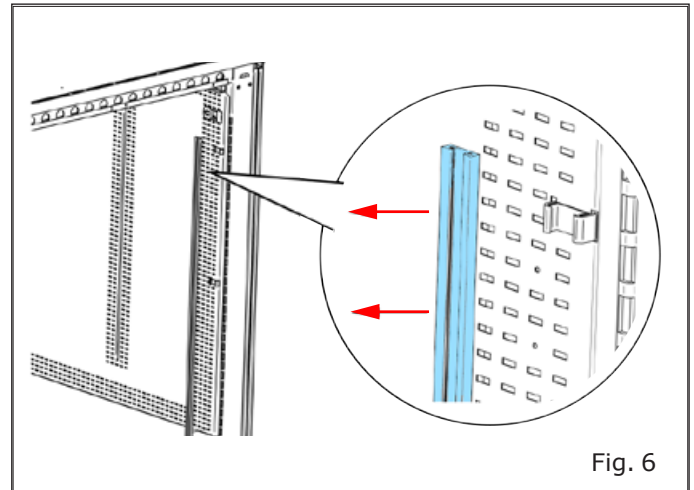

Modello - Modèle - Model Modell - Modelo - Modelo	GRANVISTA INTEGRAL AIR	COSTAN eptarefrigeration
Fabbricante - Constructeur - Manufacturer Hersteller - Fabricante - Fabricante	Epta Spa - Via Mecenate, 86 - 20138 Milano (MI) ITALIA Tel. 02/55403211 Telefax 02/55401023	7/10

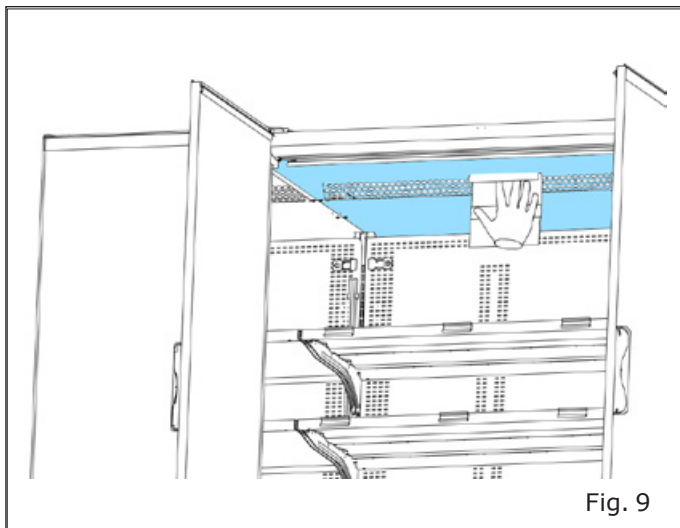

Fig. 9

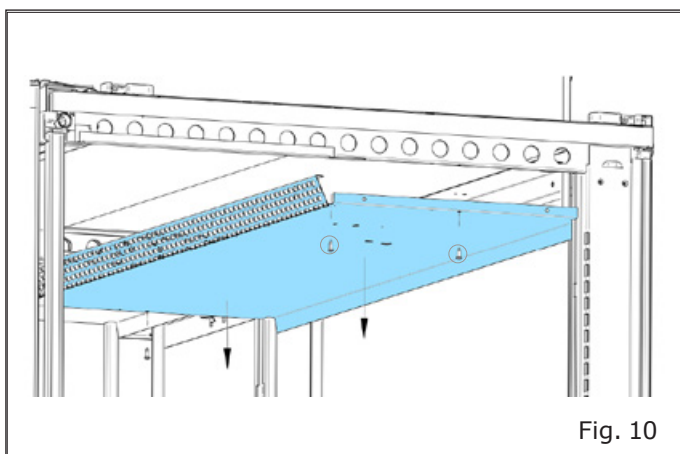

Fig. 10

3.3 Limpeza do deck base



A limpeza do deck de base deve ser feita apenas por pessoal treinado.

- Evite interromper a cadeia de refrigeração.
- Desconecte o gabinete da fonte de alimentação elétrica e proteja-o contra reconexão por pessoas não autorizadas.
- Retire as grelhas de retorno de ar e limpe-as com um pano húmido.

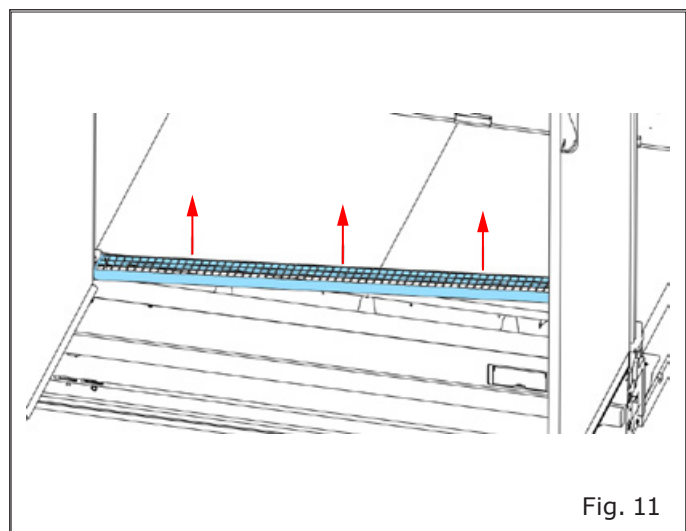

Fig. 11

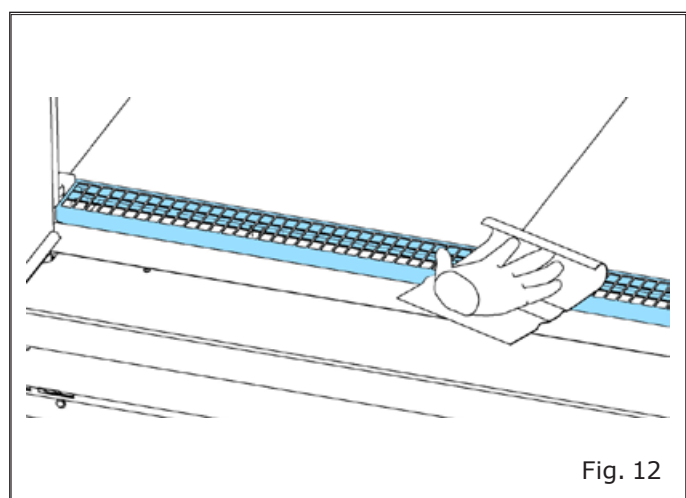
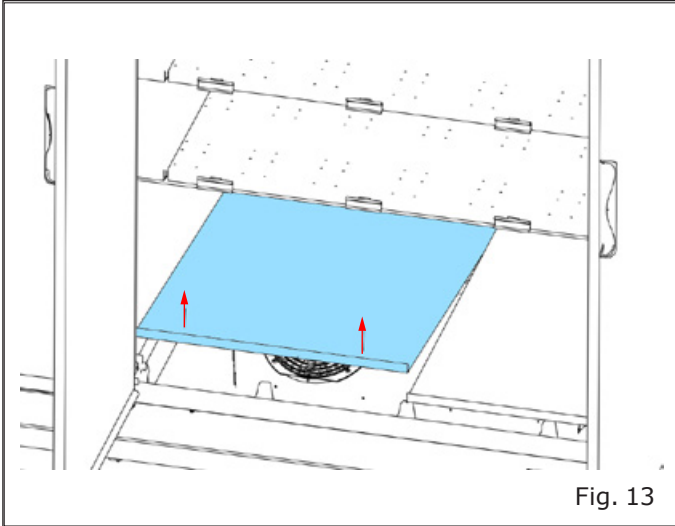

Fig. 12

Cleaning instruction

- Retire o deck base.



- Limpe-o com um pano úmido.

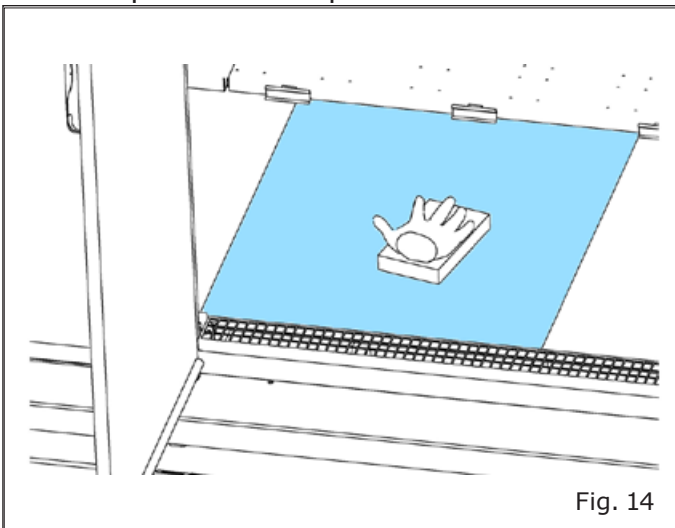

Esteja ciente dos ventiladores rotativos do evaporador! Não os toque com o dedo, trapos ou outras ferramentas.

- Limpe a bandeja da base com sabão neutro ou detergente em água morna. Verifique se o dreno está desobstruído.

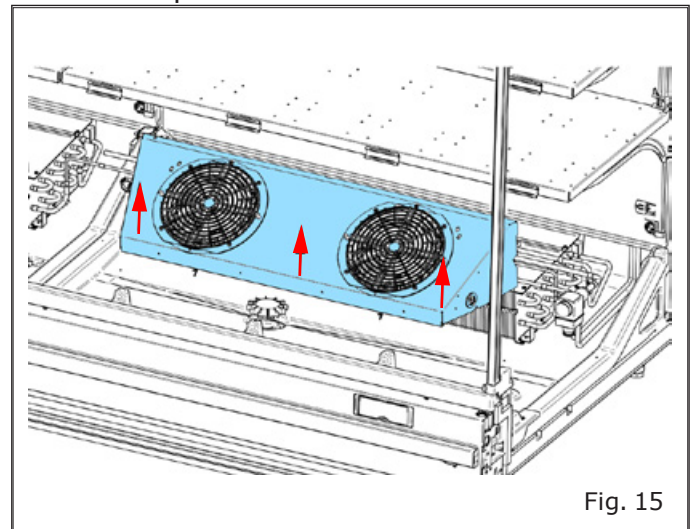

- Aspire dentro do ralo usando um aspirador de pó úmido para remover quaisquer partículas.

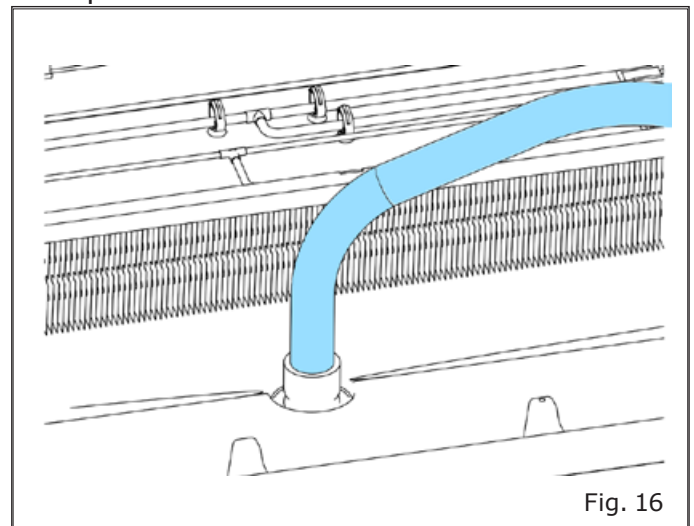

Modello - Modèle - Model Modell - Modelo - Modelo	GRANVISTA INTEGRAL AIR	COSTAN eptarefrigeration
Fabbricante - Constructeur - Manufacturer Hersteller - Fabricante - Fabricante	Epta Spa - Via Mecenate, 86 - 20138 Milano (MI) ITALIA Tel. 02/55403211 Telefax 02/55401023	9/10

- Enxágue o dreno com água.

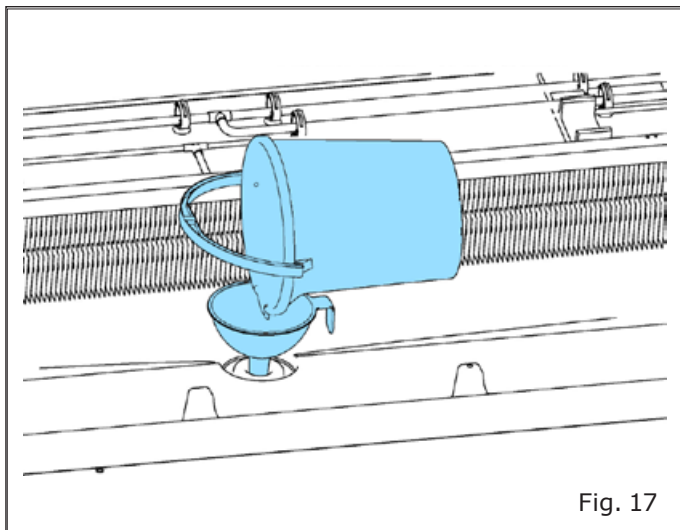

- Limpe completamente a abertura de drenagem e enxágue com água corrente.

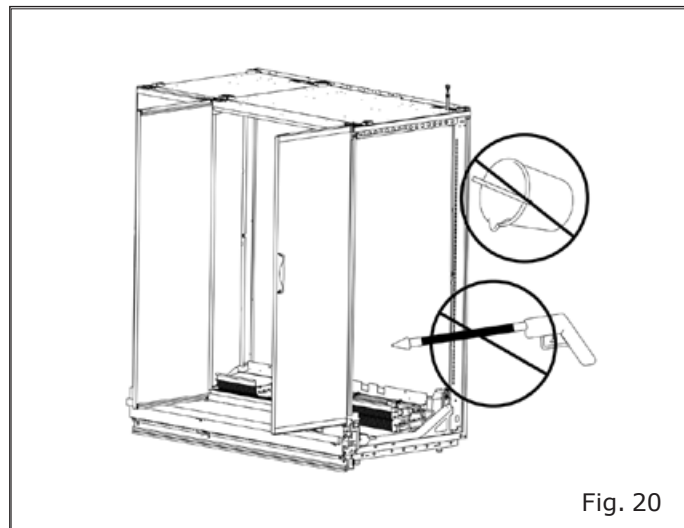
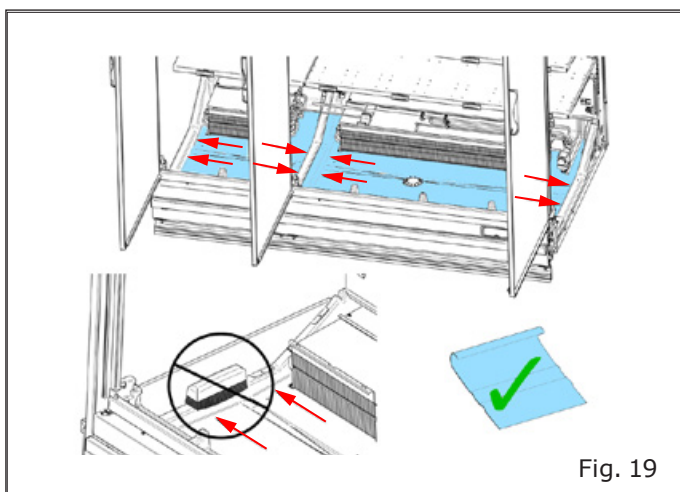
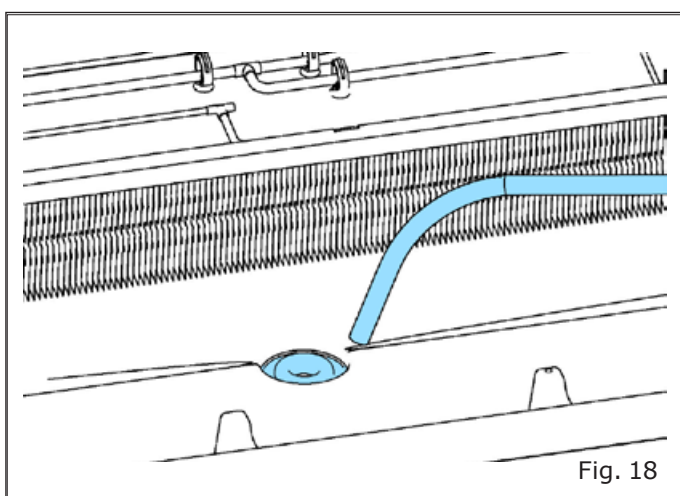

3.4 Limpeza do condensador

- Se o condensador estiver sujo com poeira, o calor não poderá mais ser dissipado e o gabinete do freezer poderá falhar. Portanto, a inspeção e a limpeza regulares são necessárias.
- No caso de uma configuração back to back, com uma escada, remova do topo a máscara do condensador entre os dois gabinetes.

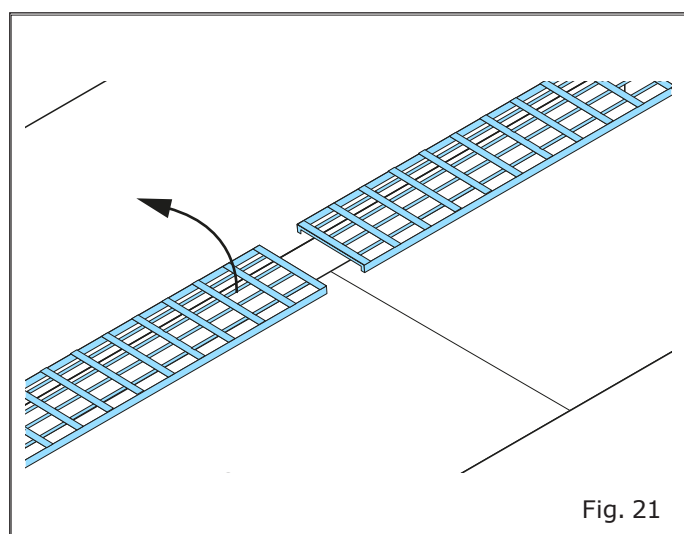

Modello - Modèle - Model Modell - Modelo - Modelo	GRANVISTA INTEGRAL AIR	COSTAN eptarefrigeration
Fabbricante - Constructeur - Manufacturer Hersteller - Fabricante - Fabricante	Epta Spa - Via Mecenate, 86 - 20138 Milano (MI) ITALIA Tel. 02/55403211 Telefax 02/55401023	10/10

Cleaning instruction

IT
FR
EN
DE
ES
PT

- Limpe o condensador com um aspirador industrial ou uma escova manual.

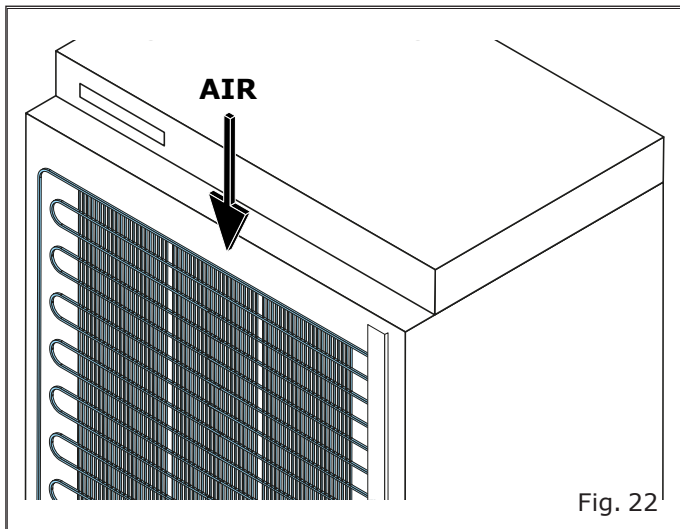

- Em seguida, reinstale a máscara do condensador.
- Remova o defletor do ventilador.

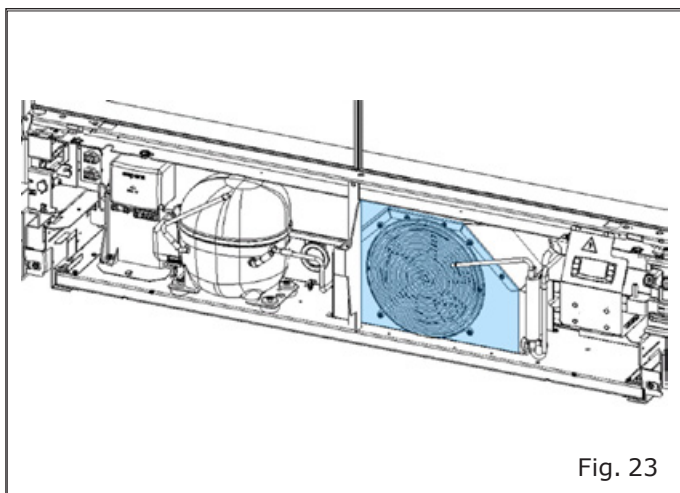

- Limpeza da tigela

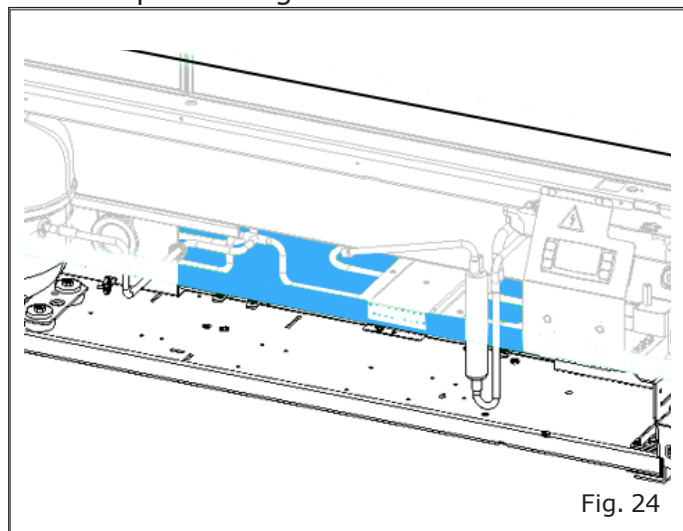

3.5 montagem do gabinete

Siga as mesmas fases de desmontagem na ordem inversa:

- Reinstale a estrutura interna e as prateleiras.
- Certifique-se de que os suportes estão na posição correta e que os suportes travam completamente no suporte ao reinstalá-los.
- Reinstale o deck de base.
- Reinstale a grade de retorno de ar.

3.6 Reinício do gabinete

- Após concluir a limpeza e verificar atentamente se o interior do gabinete está completamente seco, coloque o aparelho novamente em operação, reconectando a energia ao gabinete.
- O gabinete iniciará então seu ciclo de resfriamento. Permita que os armários atinjam uma temperatura indicada de -3°C antes de recarregar as mercadorias removidas.

Modello - Modèle - Model Modell - Modelo - Modelo	<h1>GRANVISTA INTEGRAL AIR</h1>	
Fabbricante - Constructeur - Manufacturer Hersteller - Fabricante - Fabricante	Epta Spa - Via Mecenate, 86 - 20138 Milano (MI) ITALIA Tel. 02/55403211 Telefax 02/55401023	11/12

- IT
- FR
- EN
- DE
- ES
- PT

COSTAN 
eptarefrigeration
www.costan.com

Epta
Advanced Solutions
for your Store

Epta S.p.A. participates in the ECC programme for:
Refrigerated display cabinets (RDC). Check ongoing validity
of certificate online: www.eurovent-certification.com

EN ISO 9001
EN ISO 14001
EN ISO 45001
DIN EN 15252
DIN EN 15253



www.eptarefrigeration.com